



HOSHIZAKI

Parts List

Modular Crescent Cuber

Model

KMD-410MWJ



hoshizakiamerica.com

Number: F130-4622
Issued: 09-2024

Auxiliary Codes

KMD-410MWJ	H-1	September 2018
KMD-410MWJ	L-1	December 2021

Auxiliary Code Breakdown

The auxiliary code is the first two characters in the serial number. The first character indicates the year. Years progress or regress in alphabetical order. The series runs from "A" through "V" and the letters "I" and "O" are skipped. The second character indicates significant part changes within a year. Base is "0" and this number advances for each change. In cases where there is a letter in parentheses, this designates the month. This is the last character in the serial number. The series runs from "(A)" through "(M)" and the letter "(I)" is skipped. This designation is only included when identifying a parts change within an auxiliary code.

Note About Ordering Parts

Most assemblies cannot be ordered as complete units; parts in the assemblies generally must be ordered separately.

MARKS LOCATED UNDER THE AUXILIARY CODE

- = Part deleted.

FASTENER PART NUMBER

SCREWS

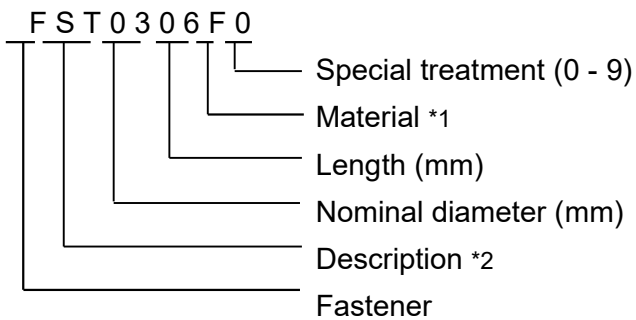

*1

F: Steel
S: Austenitic stainless steel
M: Martensitic stainless steel
B: Copper alloy
P: Polycarbonate
N: Polyamide
V: PVC
A: ABS
X: Polyacetal
L: Aluminum

NUTS & WASHERS

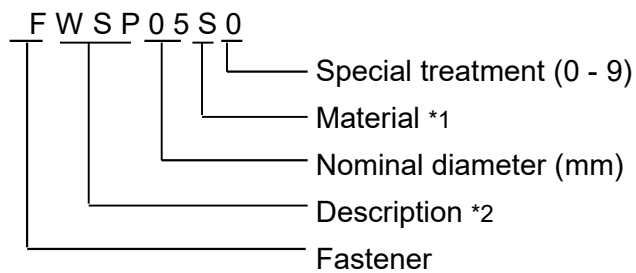

*2

First letter
S: Machine screw
T: Tapping screw
M: Wood screw
B: Bolt
W: Washer
N: Nut

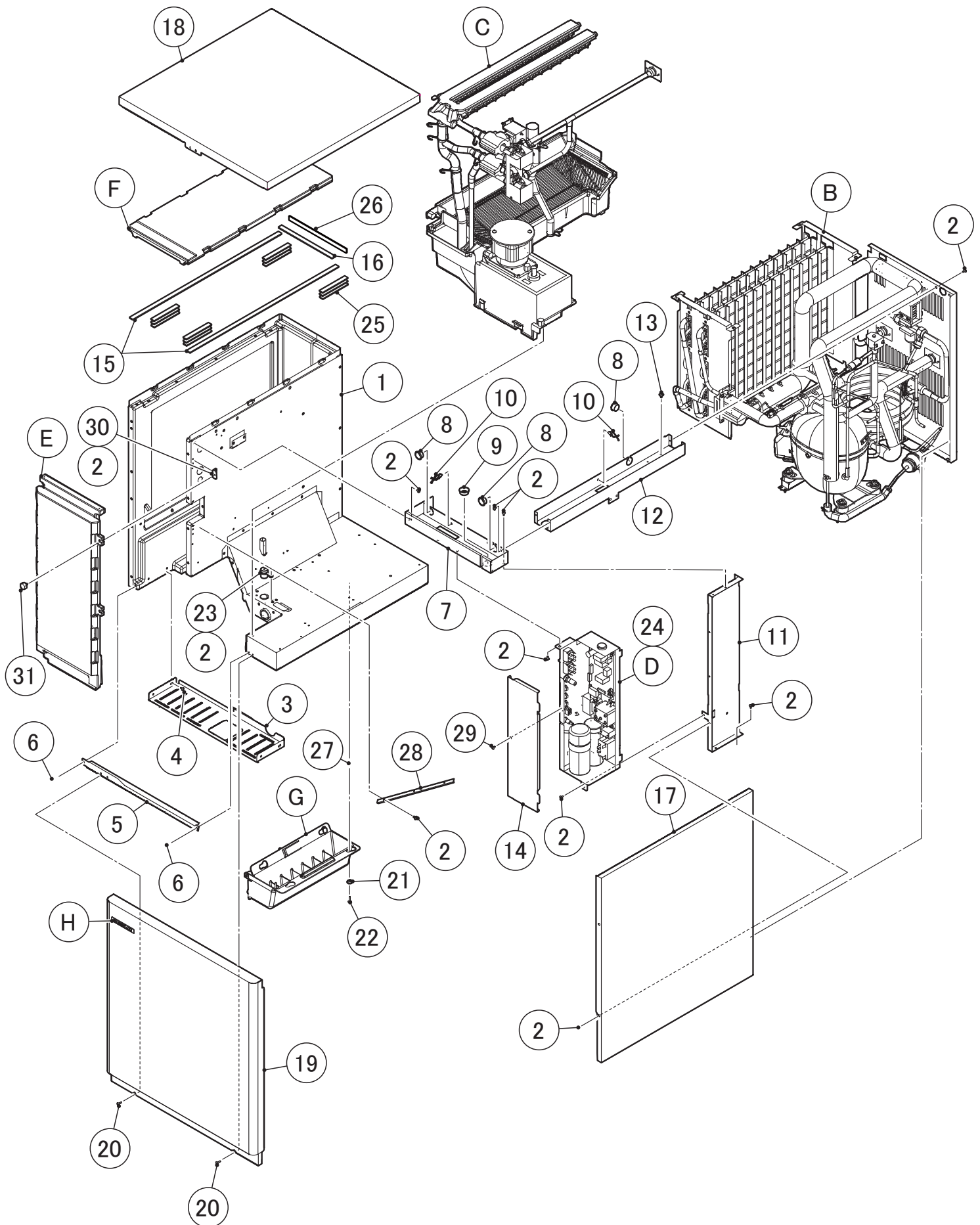

HA

MODEL: KMD-410MWJ				TITLE: A. ICE CUBER ASSY				
INDEX NO.	DESCRIPTION	MATERIAL OR MODEL NUMBER	PART NUMBER	REQ'D NUMBER				
				H-1,L-0	L-1			
B	REFRIGERATION CIRCUIT	F130	-	1	1			
		F130-D001	-	1	1			
C	WATER CIRCUIT	F130	-	1	1			
		F130-D001	-	1	1			
D	CONT. BOX ASSY		-	1	1			
E	FRONT INSULATION ASSY		388861A01	1	1			
F	TOP INSULATION ASSY		374537A01	1	1			
G	BIN SWITCH		-	1	1			
H	LABEL LOCATION		-	1	1			
K	ACCESSORIES		-	1	1			
M	OPTIONAL PARTS		-	1	1			
1	EVAP. CASE	F130	127328G08	1	1			
		F130-D001	127328G16	1	1			
2	T2 TRUSS HEAD SCREW	F130	FT20408F0	20	20			
		F130-D001	FT20408F0	5	5			
3	BOTTOM FRAME		275771M01	1	1			
4	T2 TRUSS HEAD SCREW		FT20408M0	4	4			
5	FRONT FRAME		388187G01	1	1			
6	TRUSS HEAD SCREW	F130	FST0408S0	6	5			
		F130-D001	FST0408S0	21	20			
7	TOP FRAME		371867M02	1	1			
8	BUSHING		428394-05	3	3			
9	BUSHING		428394-01	1	1			
10	WIRE RETAINER		427902-03	3	3			
11	SIDE FRAME (A)	F130	371873M01	1	1			
		F130-D001	371873M02	1	1			
12	SIDE FRAME (B)		371866M02	1	1			
13	SCREW - GROUNDING		433304-02	1	1			
14	CONT. BOX COVER		371874M01	1	1			
15	GASKET		127733Z01	2	2			
16	GASKET		127733Z02	1	1			

HA

MODEL: KMD-410MWJ		TITLE: A. ICE CUBER ASSY						
INDEX NO.	DESCRIPTION	MATERIAL OR MODEL NUMBER	PART NUMBER	REQ'D NUMBER				
				H-1,L-0	L-1			
17	SIDE PANEL (R)		255966G08	1	-			
	SIDE PANEL (R1)		255966M12	-	1			
18	TOP PANEL		274705M02	1	1			
19	FRONT PANEL		373166G01	1	1			
20	TRUSS HEAD MACHINE SCREW		FST0420S0	2	2			
21	COLLAR		435269-01	4	4			
22	T2 TRUSS HEAD SCREW		FT20416M0	4	4			
23	HOLE PLUG		373078R01	1	1			
24	WIRE HARNESS		373139Z02	1	1			
25	GASKET		127733Z03	12	12			
26	GASKET		127733Z04	1	1			
27	FLAT WASHER		FWPL04S0	4	4			
28	PLATE - SIDE PANEL	F130	379577M01	1	1			
		F130-D001	379577M02	1	1			
29	PAN HEAD SCREW SW		FSK0412S0	1	5			
30	BRACKET (A) - INSULATION	F130	484783M01	2	2			
		F130-D001	484783M02	2	2			
31	THUMB SCREW		415949G13	4	4			

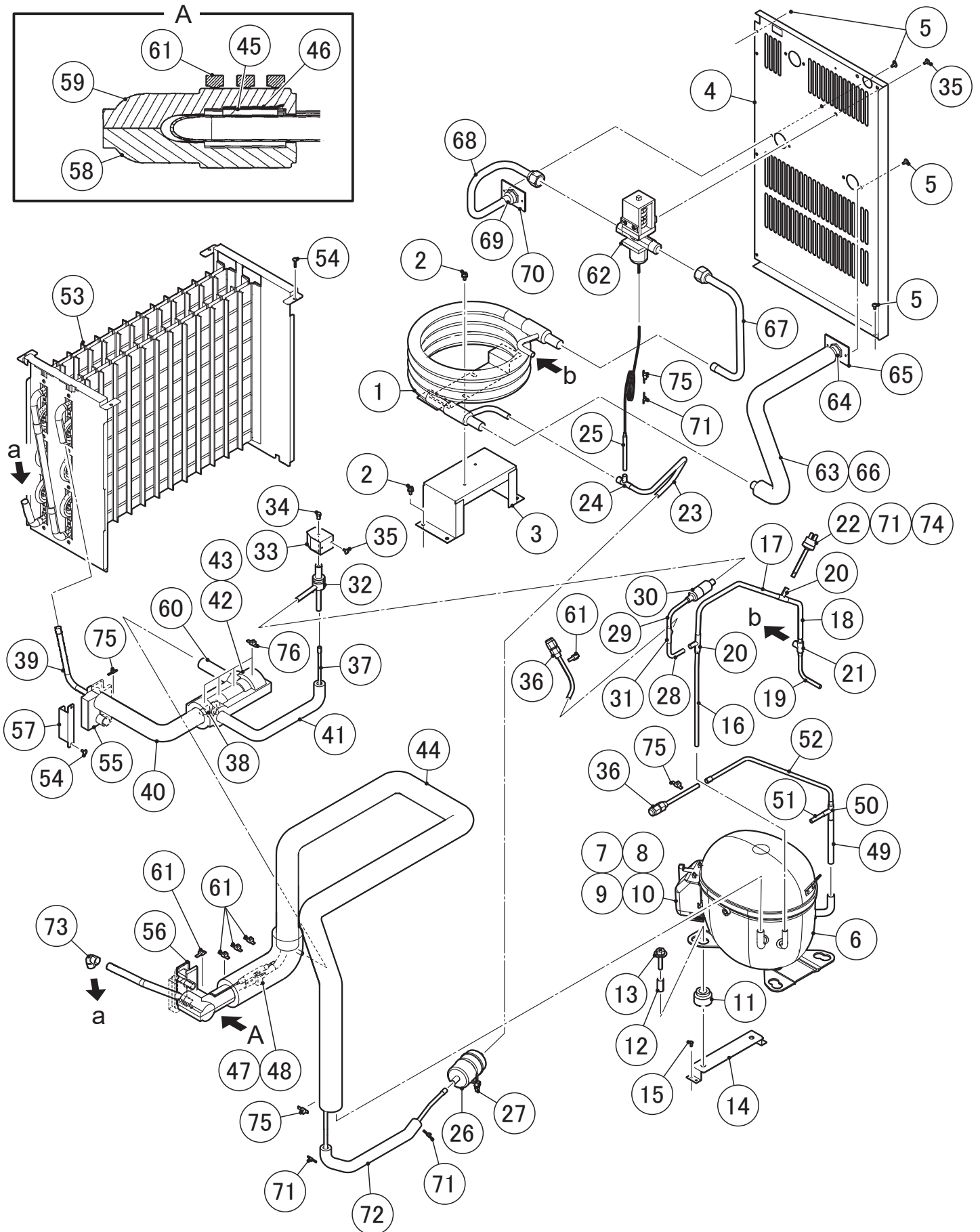

HA

MODEL: KMD-410MWJ		TITLE: B. REFRIGERATION CIRCUIT						
INDEX NO.	DESCRIPTION	MATERIAL OR MODEL NUMBER	PART NUMBER	REQ'D NUMBER				
				H-1,L-0	L-1			
1	CONDENSER - WATER COOLED		P01212-01	1	1			
2	HEX HEAD BOLT W/WASHER [SW]		FBK0510S0	6	6			
3	BASE - CONDENSER WATER COOLED		372520M01	1	1			
4	REAR PANEL		256723M02	1	1			
5	T2 TRUSS HEAD SCREW	F130	FT20408F0	9	9			
		F130-D001	FT20408F0	8	8			
6	COMPRESSOR		P01550-01	1	1			
7	TERMINAL COVER		P02814-01	1	1			
8	PROTECTOR		P01552-01	1	1			
9	PROTECTOR RETAINER		P02815-01	1	1			
10	SCREW		P00840-01	1	1			
11	GROMMET		P00846-01	4	4			
12	SPACER		P00847-01	4	4			
13	BOLT		436206-03	4	4			
14	COMP. MOUNT		371868G01	2	2			
15	RIVET		7170-0005	8	8			
16	COPPER TUBE (A1) - HIGH SIDE	COPPER TUBE (A) - HIGH SIDE 256728G01	256728M01	1	1			
17	COPPER TUBE (A2) - HIGH SIDE	COPPER TUBE (A) - HIGH SIDE 256728G01	256728M02	1	1			
18	COPPER TUBE (A3) - HIGH SIDE	COPPER TUBE (A) - HIGH SIDE 256728G01	256728M03	1	1			
19	COPPER TUBE (A4) - HIGH SIDE	COPPER TUBE (A) - HIGH SIDE 256728G01	256728M04	1	1			
20	TEE	COPPER TUBE (A) - HIGH SIDE 256728G01	420041-02	2	2			
21	TEE	COPPER TUBE (A) - HIGH SIDE 256728G01	420041-16	1	1			
22	PRESSURE SWITCH		P05220-05	1	1			

HA

MODEL: KMD-410MWJ		TITLE: B. REFRIGERATION CIRCUIT						
INDEX NO.	DESCRIPTION	MATERIAL OR MODEL NUMBER	PART NUMBER	REQ'D NUMBER				
				H-1,L-0	L-1			
23	COPPER TUBE (B1) - HIGH SIDE	COPPER TUBE (B) - HIGH SIDE 372527G01	372527M01	1	1			
24	TEE	COPPER TUBE (B) - HIGH SIDE 372527G01	4A1545-02	1	1			
25	COPPER TUBE (B) - CAPILLARY		446047-02	1	1			
26	DRIER		P02070-01	1	-			
			P05348-01	-	1			
27	TIE		436156-02	1	1			
28	COPPER TUBE (D1) - HIGH SIDE	COPPER TUBE (D) - HIGH SIDE 371885G01	371885M01	1	1			
29	COPPER TUBE (D2) - HIGH SIDE	COPPER TUBE (D) - HIGH SIDE 371885G01	371885M02	1	1			
30	STRAINER	COPPER TUBE (D) - HIGH SIDE 371885G01	P00812-01	1	1			
31	TEE-6.4	COPPER TUBE (D) - HIGH SIDE 371885G01	417394-01	1	1			
32	VALVE BODY		4A3978-01	1	1			
33	COIL-VALVE		4A3277-01	1	-			
	HOT GAS VALVE COIL-HARNESS		3C0334G01	-	1			
34	BOLT		4A3277F01	1	1			
35	TRUSS HEAD SCREW	F130	FST0408S0	4	4			
		F130-D001	FST0408S0	7	7			
36	ACCESS VALVE		457729-01	2	2			
37	COPPER TUBE (E1) - HOT GAS	COPPER TUBE (E) - HOT GAS 388846G02	372521M01	1	1			
38	TEE	COPPER TUBE (E) - HOT GAS 388846G02	420335-01	1	1			
39	COPPER TUBE (E2) - HOT GAS	COPPER TUBE (E) - HOT GAS 388846G02	338845M01	1	1			

HA

MODEL: KMD-410MWJ		TITLE: B. REFRIGERATION CIRCUIT						
INDEX NO.	DESCRIPTION	MATERIAL OR MODEL NUMBER	PART NUMBER	REQ'D NUMBER				
				H-1,L-0	L-1			
40	INSULATION TUBE	COPPER TUBE (E) - HOT GAS 388846G02 L=290	H71030290	1	1			
41	INSULATION TUBE	COPPER TUBE (E) - HOT GAS 388846G02 L=360	H71020360	1	1			
42	EXPANSION VALVE		4A1414-02	1	1			
43	EXPANSION VALVE COVER		3A0944-01	1	1			
44	HEAT EXCHANGER		276950G02	1	1			
45	THERMISTOR		P00027-01	1	1			
46	HOLDER - THERMISTOR		427430-01	1	1			
47	HOLDER - EXP. VALVE 3/8		3C0058M01	1	1			
48	CLAMP		443461-02	1	1			
49	COPPER TUBE (F1) - ACCESS VALVE	COPPER TUBE (F) - ACCESS VALVE 371877G01	371877M01	1	1			
50	TEE	COPPER TUBE (F) - ACCESS VALVE 371877G01	417394-01	1	1			
51	COPPER TUBE (F2) - ACCESS VALVE	COPPER TUBE (F) - ACCESS VALVE 371877G01	371877M03	1	1			
52	COPPER TUBE (F3) - ACCESS VALVE	COPPER TUBE (F) - ACCESS VALVE 371877G01	371877M04	1	1			
53	EVAPORATOR ASSY		276955G01	1	1			
54	T2 TRUSS HEAD SCREW	F130	FT20408M0	2	2			
		F130 F130-D001	FT20416M0	4	4			
55	RUBBER INSULATION (B)		3C0066R01	1	1			
56	RUBBER INSULATION (A)		3C0067R01	1	1			
57	INSULATION HOLDER		473043M01	1	1			
58	INSULATION - THERMISTOR (A)		439368-01	1	1			
59	INSULATION - THERMISTOR (B)		439368-02	1	1			
60	INSULATION TUBE		H71020090	1	1			

HA

MODEL: KMD-410MWJ		TITLE: B. REFRIGERATION CIRCUIT						
INDEX NO.	DESCRIPTION	MATERIAL OR MODEL NUMBER	PART NUMBER	REQ'D NUMBER				
				H-1,L-0	L-1			
61	NYLON TIE		7920-0010	15	12			
62	WATER REGULATOR		P05010-01	1	1			
63	COPPER TUBE (A1) - WATER CIRCUIT	COPPER TUBE (A) - WATER CIRCUIT 372524G01	372524M01	1	1			
64	INLET FITTING	COPPER TUBE (A) - WATER CIRCUIT 372524G01	P01214-01	1	1			
65	FITTING HOLDER	COPPER TUBE (A) - WATER CIRCUIT 372524G01	4A0764-01	1	1			
66	INSULATION TUBE	COPPER TUBE (A) - WATER CIRCUIT 372524G01 L=430	H71333430	1	1			
67	COPPER TUBE (B) - WATER CIRCUIT		372525M01	1	1			
68	COPPER TUBE (C1) - WATER CIRCUIT	COPPER TUBE (C) - WATER CIRCUIT 372526G01	372526M01	1	1			
69	INLET FITTING	COPPER TUBE (C) - WATER CIRCUIT 372526G01	P01214-01	1	1			
70	FITTING HOLDER	COPPER TUBE (C) - WATER CIRCUIT 372526G01	4A0764-01	1	1			
71	TIE		7920-0002	5	4			
72	INSULATION TUBE		H71020245	1	1			
73	ELBOW		417395-03	1	1			
74	BAG		485815P01	1	1			
75	TIE	CV-150	7920-0003	-	4			
76	NYLON TIE	CV-250	7920-0011	-	-			

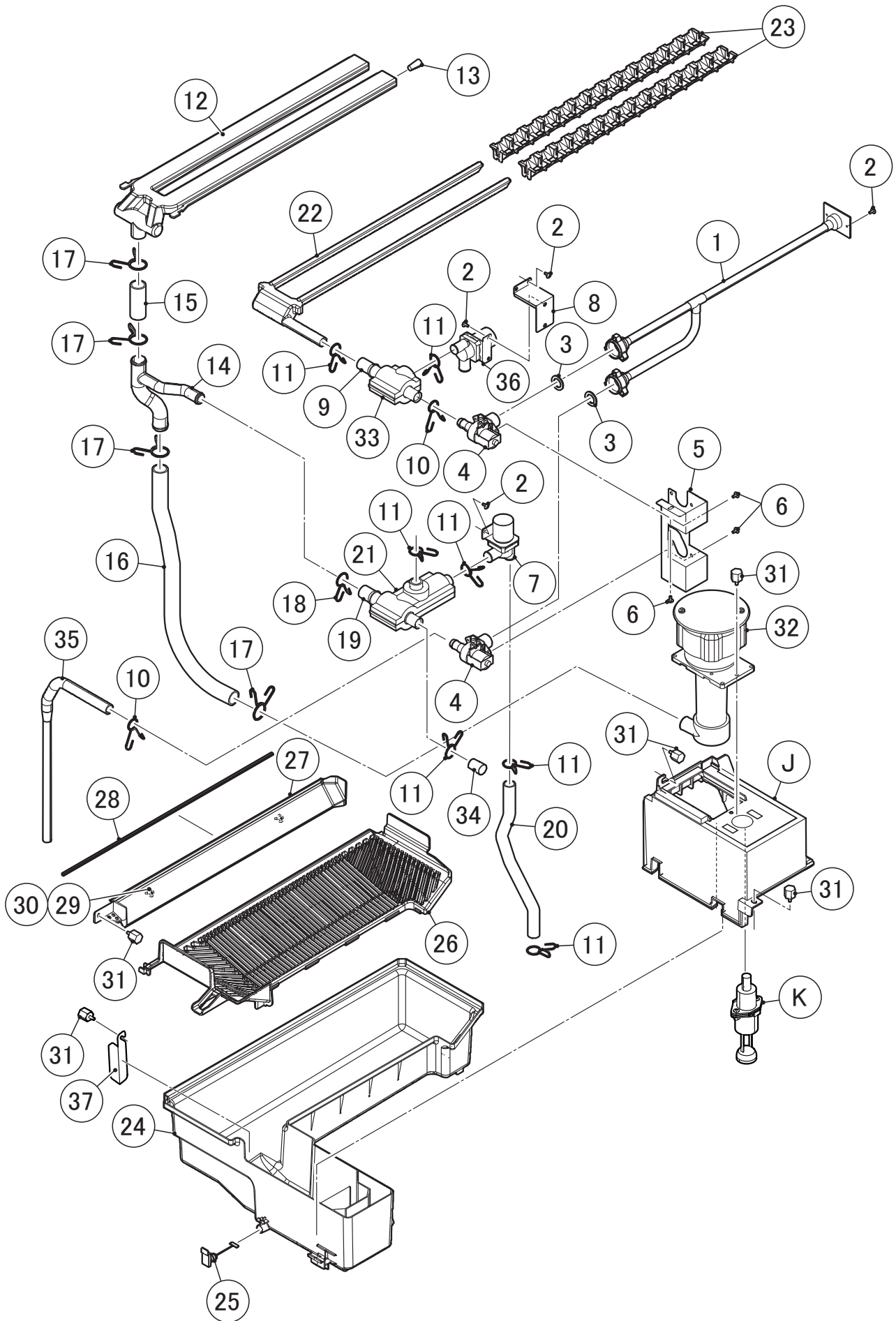

HA

MODEL: KMD-410MWJ		TITLE: C. WATER CIRCUIT ASSY						
INDEX NO.	DESCRIPTION	MATERIAL OR MODEL NUMBER	PART NUMBER	REQ'D NUMBER				
				H-1,L-0	L-1			
J	PUMP BRACKET ASSY		388856A01	1	1			
K	FLOAT SW. ASSY		389075A02	1	1			
1	WATER SUPPLY PIPE		371882G02	1	1			
2	T2 SCREW	F130	FT20408F0	9	9			
		F130-D001	FT20408F0	5	5			
3	RUBBER GASKET		413854-03	2	2			
4	WATER VALVE		P01559-01	2	-			
			4C0227G01	-	2			
5	WATER VALVE BRACKET		371875G02	1	1			
6	TRUSS HEAD SCREW	F130	FST0408S0	4	5			
		F130-D001	FST0408S0	8	8			
7	SOLENOID VALVE		P00018-02	2	-			
	DRAIN VALVE (G)		3C0351G01	-	1			
8	BRACKET - NSF VALVE		474226M01	1	1			
9	TEE		371167R01	1	1			
10	HOSE CLAMP ※Use either of the right		427443-04	2	2			
			P02909-04	2	2			
11	HOSE CLAMP ※Use either of the right		427443-05	7	7			
			P02909-05	7	7			
12	SPRAY TUBE		127382P01	1	1			
13	PLUG		4C0037R01	2	2			
14	CONNECTING PIPE		388309P01	1	1			
15	SILICONE HOSE	Φ20XΦ 25(CLEAR)L=60	H12025060	1	1			
16	SILICONE HOSE	Φ20XΦ 25(CLEAR)L=465	H12025465	1	1			
17	HOSE CLAMP ※Use either of the right		427443-03	4	4			
			C06092-01	4	4			
18	HOSE CLAMP ※Use either of the right		427443-06	1	1			
			P02909-06	1	1			
19	BYPASS HOSE		371165R01	1	1			
20	SILICONE HOSE	Φ15XΦ 19(CLEAR)L=340	H11519340	1	1			
21	BYPASS INSULATION		371169Z01	1	1			

HA

MODEL: KMD-410MWJ		TITLE: C. WATER CIRCUIT ASSY						
INDEX NO.	DESCRIPTION	MATERIAL OR MODEL NUMBER	PART NUMBER	REQ'D NUMBER				
				H-1,L-0	L-1			
22	WATER SUPPLY TUBE		276018P01	1	1			
23	SPRAY GUIDE		252052P03	2	2			
24	WATER TANK		127337P01	1	1			
25	DRAIN CAP		371168G01	1	1			
26	CUBE GUIDE		118904P01	1	1			
27	DEFLECTOR (L)		255250P01	1	1			
28	GASKET		371166R01	1	1			
29	COLLAR		435269-01	2	2			
30	T2 TRUSS HEAD SCREW		FT20416M0	2	2			
31	THUMBSCREW		415949G12	4	5			
32	PUMP MOTOR		391582G01	1	1			
33	INLET INSULATION		373079Z01	1	1			
34	PLUG		472567P01	1	1			
35	WATER SUPPLY PIPE (B)		484865P01	1	1			
36	DRAIN VALVE (G)		3C0351G02	-	1			
37	BARRIER - KMD		487742M01	-	1			

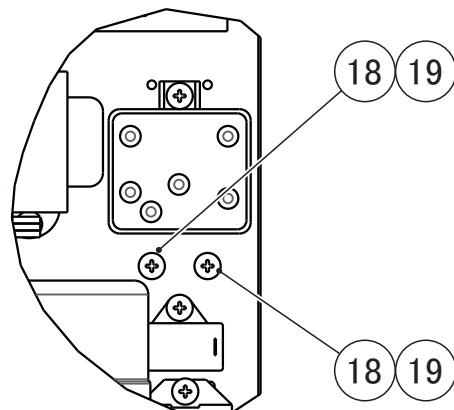
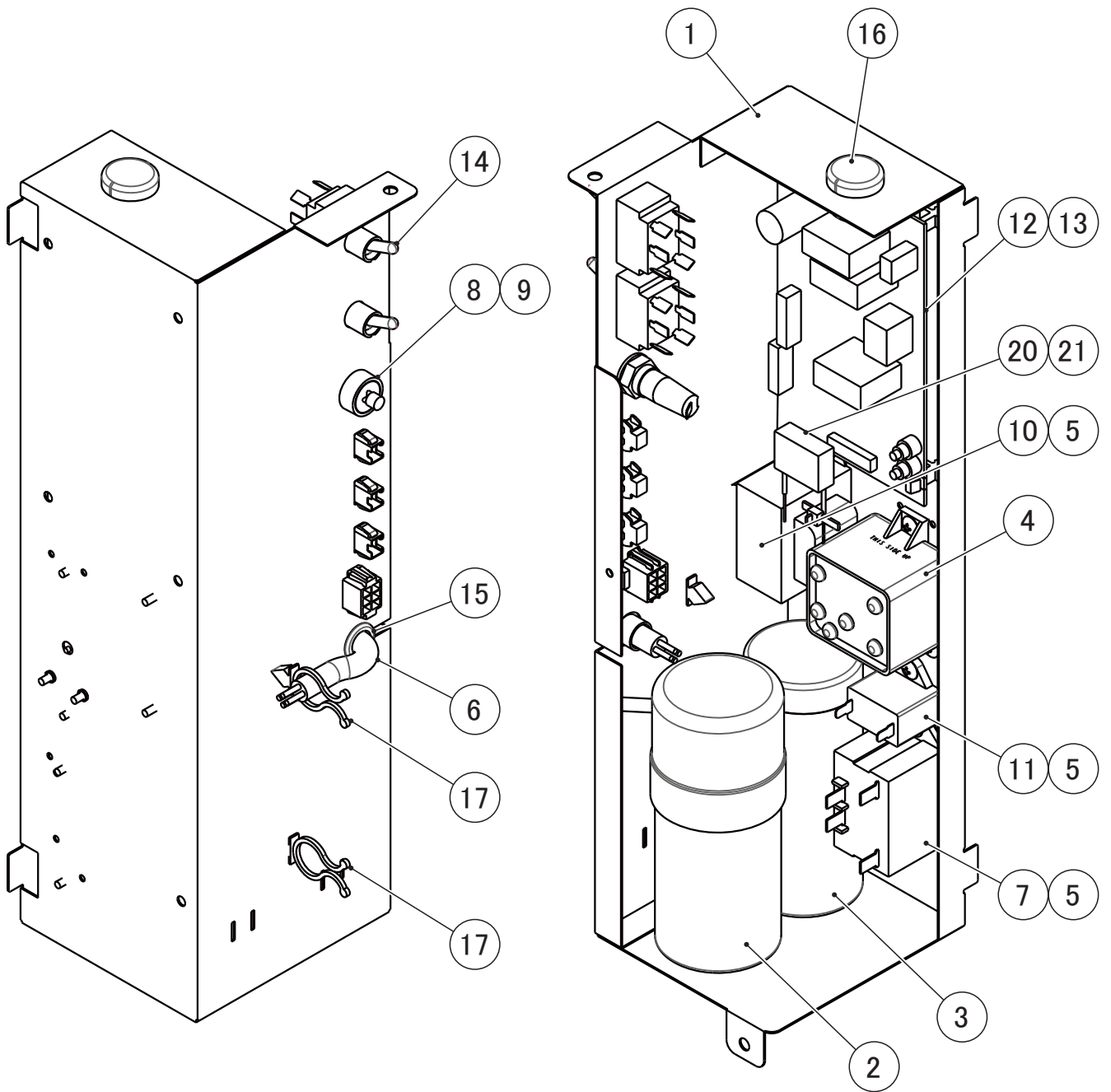

HA

MODEL: KMD-410MWJ		TITLE: D. CONTROL BOX ASSY						
INDEX NO.	DESCRIPTION	MATERIAL OR MODEL NUMBER	PART NUMBER	REQ'D NUMBER				
				H-1,L-0	L-1			
1	CONTROL BOX		274706M01	1	1			
2	RUN CAPACITOR		P02699-01	1	1			
3	START CAPACITOR		P02867-01	1	1			
4	STARTER		P01554-01	1	1			
5	T2 TRUSS HEAD SCREW		FT20408F0	6	6			
6	WIRE KIT		P06528-01	1	1			
7	POWER RELAY		449000-01	1	1			
8	FUSE HOLDER		P00014-01	1	1			
9	FUSE		420468-02	1	1			
10	TRANSFORMER		3A4395-01	1	1			
11	CAPACITOR		4A2128-05	1	1			
12	CONTROLLER BOARD		P01771-02	1	1			
13	BOARD SUPPORT		P01770-01	4	4			
14	TOGGLE SWITCH		P05888-01	2	2			
15	BUSHING		428394-03	1	1			
16	BUSHING		420472-05	1	1			
17	WIRE RETAINER		427902-05	2	2			
18	SPRING WASHER		FWSP04S0	2	2			
19	TRUSS HEAD SCREW		FST0408S0	2	2			
20	CAPACITOR (NOISE SUPPRESSION)		P00228-01	1	1			
21	TIE		7920-0003	1	1			

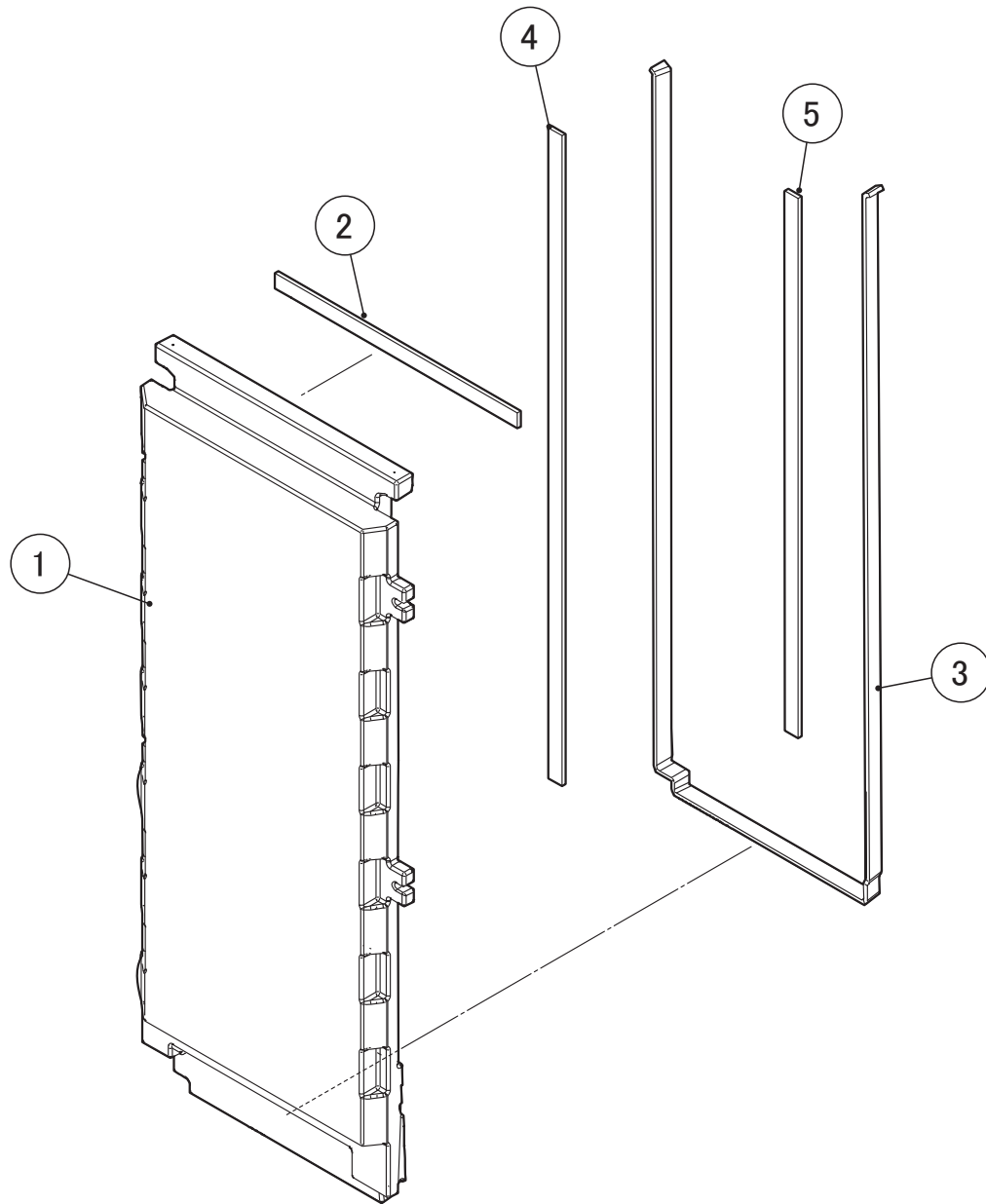

HA

MODEL: KMD-410MWJ		TITLE: E. FRONT INSULATION ASSY						
INDEX NO.	DESCRIPTION	MATERIAL OR MODEL NUMBER	PART NUMBER	REQ'D NUMBER				
				H-1,L-0	L-1			
1	FRONT INSULATION		275773G01	1	1			
2	GASKET		388861Z02	1	1			
3	GASKET		388861Z03	1	1			
4	GASKET		388861Z04	1	1			
5	GASKET		388861Z05	1	1			

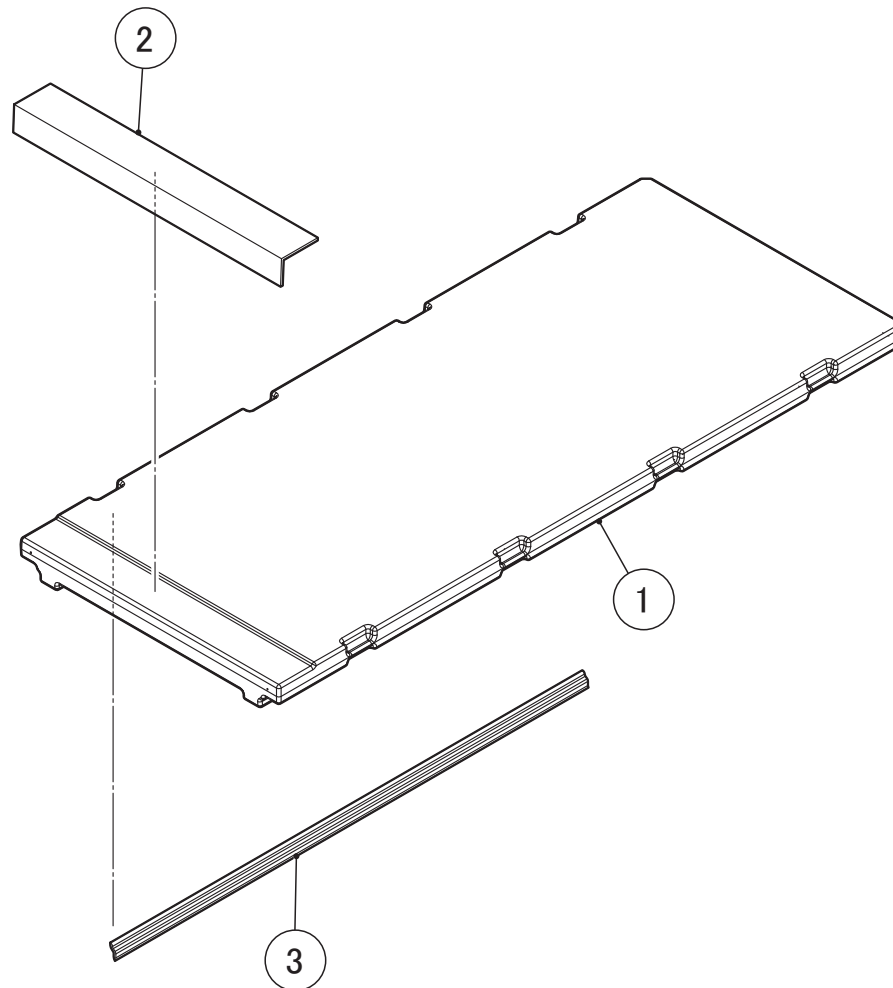

HA

MODEL: KMD-410MWJ		TITLE: F. TOP INSULATION ASSY						
INDEX NO.	DESCRIPTION	MATERIAL OR MODEL NUMBER	PART NUMBER	REQ'D NUMBER				
				H-1,L-0	L-1			
1	TOP INSULATION		255254G01	1	1			
2	INSULATION		473041Z01	1	1			
3	GASKET		374537Z03	1	1			

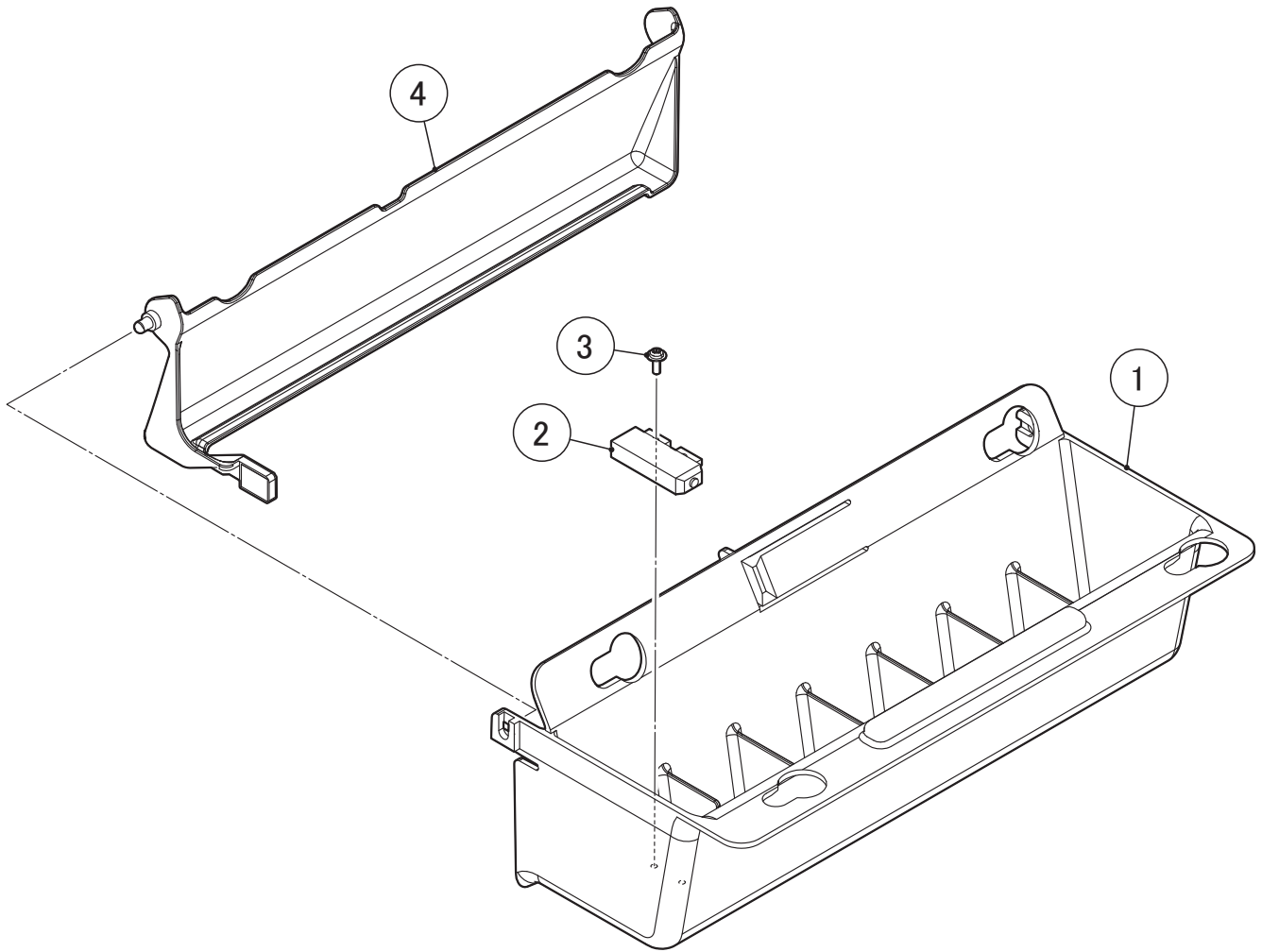

HA

MODEL: KMD-410MWJ		TITLE: G. BIN SWITCH						
INDEX NO.	DESCRIPTION	MATERIAL OR MODEL NUMBER	PART NUMBER	REQ'D NUMBER				
				H-1,L-0	L-1			
1	SWITCH HOUSING		255248P01	1	1			
2	REED SWITCH		P02304-04	1	1			
3	TAPPING SCREW		431415-03	2	2			
4	DETECTOR		371158G01	1	1			

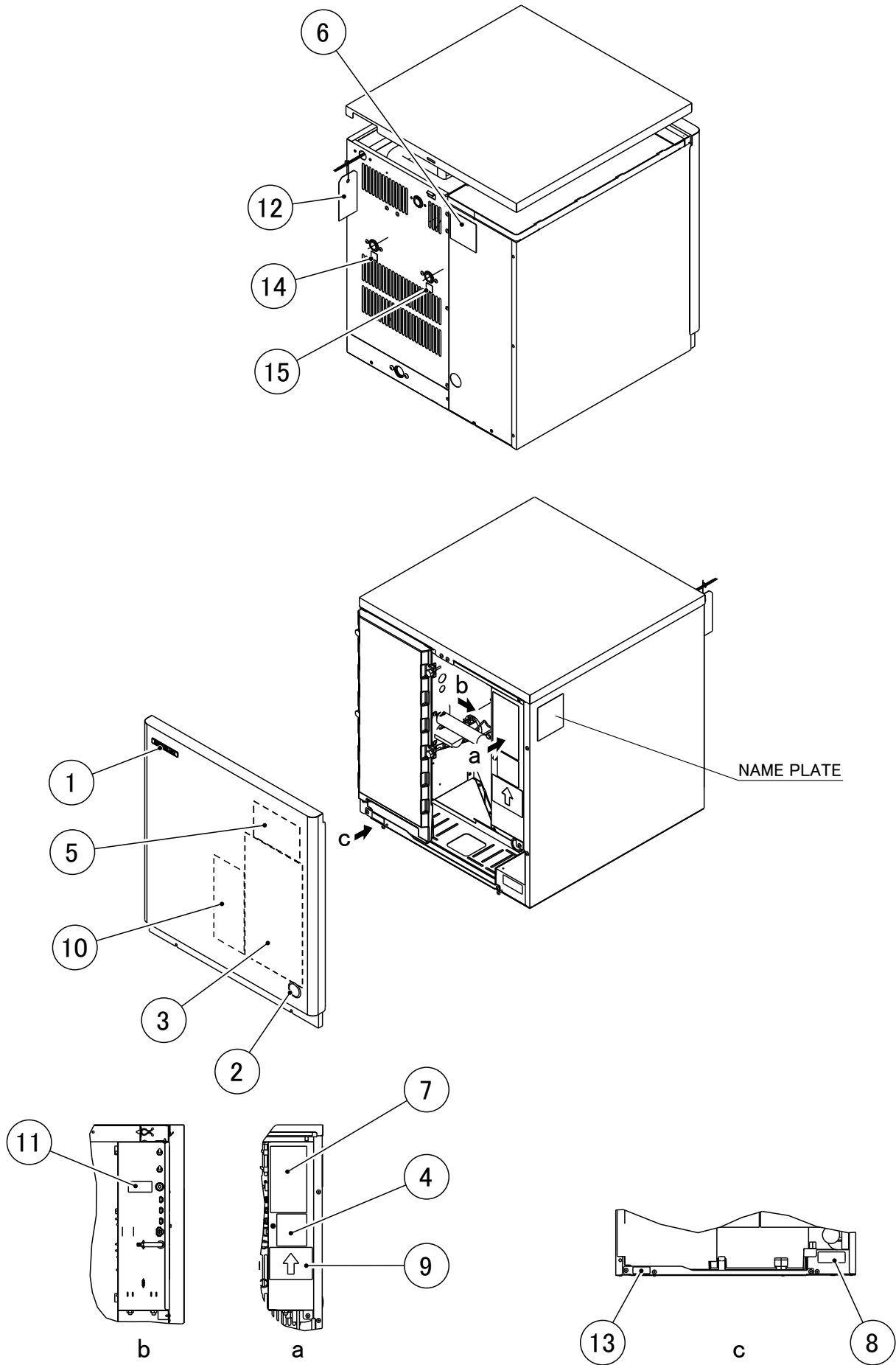

HA

MODEL: KMD-410MWJ		TITLE: H. LABEL LOCATION						
INDEX NO.	DESCRIPTION	MATERIAL OR MODEL NUMBER	PART NUMBER	REQ'D NUMBER				
				H-1,L-0	L-1			
1	EMBLEM		456245-01	1	1			
2	LABEL - PENGUIN		468184-01	1	1			
3	MAINTENANCE LABEL		276974L01	1	1			
4	CAUTION LABEL - SERVICE		471180L01	1	1			
5	WIRING LABEL		373135L01	1	1			
6	INSTRUCTION LABEL		472709L01	1	1			
7	MANUAL LABEL		371379L01	1	1			
8	LABEL/R-404A		453230-01	1	1			
9	LABEL - ALARM		370310L01	1	1			
10	LABEL - CONTROL BOARD		370605L01	1	1			
11	LABEL - FUSE		472712L01	1	1			
12	TAG - WARNING ELECT CONNECTION		4C0205L01	1	1			
13	LABEL-FRONT FRAME		484959L01	1	1			
14	LABEL - INLET		418029-04	1	1			
15	LABEL - OUTLET		418029-05	1	1			

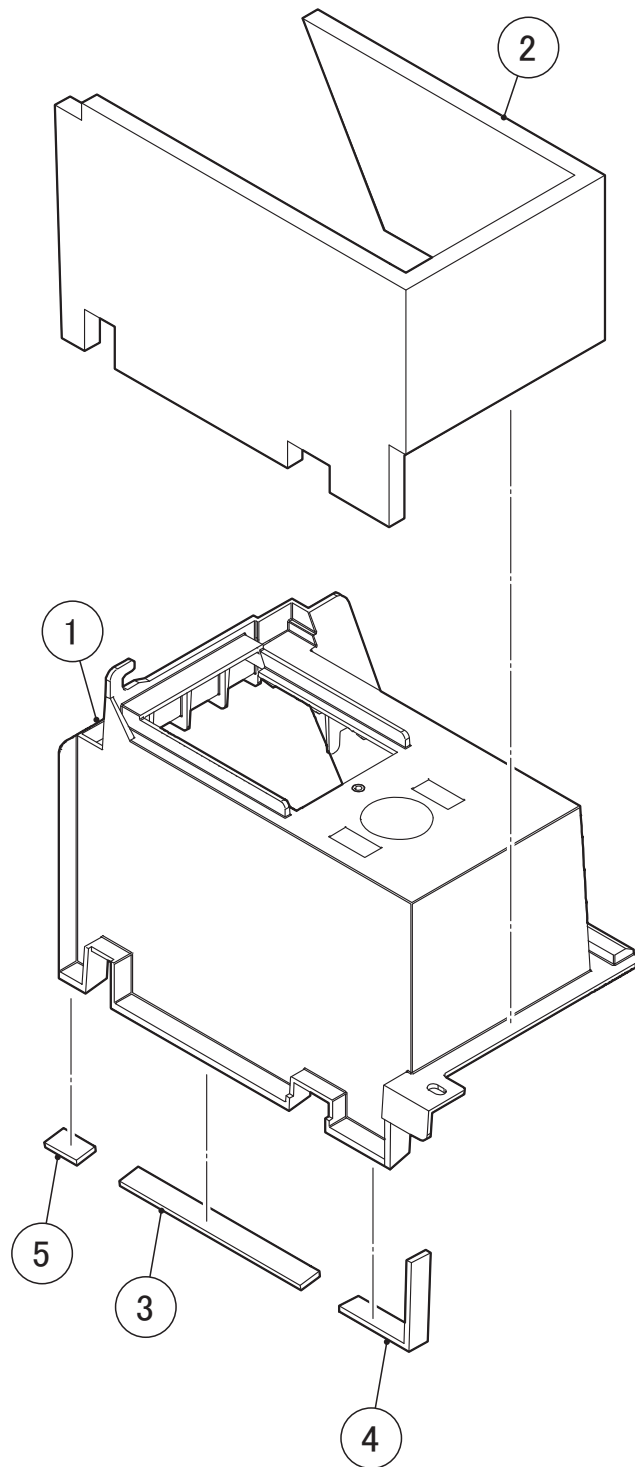

HA

MODEL: KMD-410MWJ		TITLE: J. PUMP BRACKET ASSY						
INDEX NO.	DESCRIPTION	MATERIAL OR MODEL NUMBER	PART NUMBER	REQ'D NUMBER				
				H-1,L-0	L-1			
1	PUMP BRACKET		127338G01	1	1			
2	PM BRACKET INSULATION		388191P01	1	1			
3	GASKET		388856Z01	1	1			
4	GASKET		388856Z02	1	1			
5	GASKET		388856Z03	1	1			

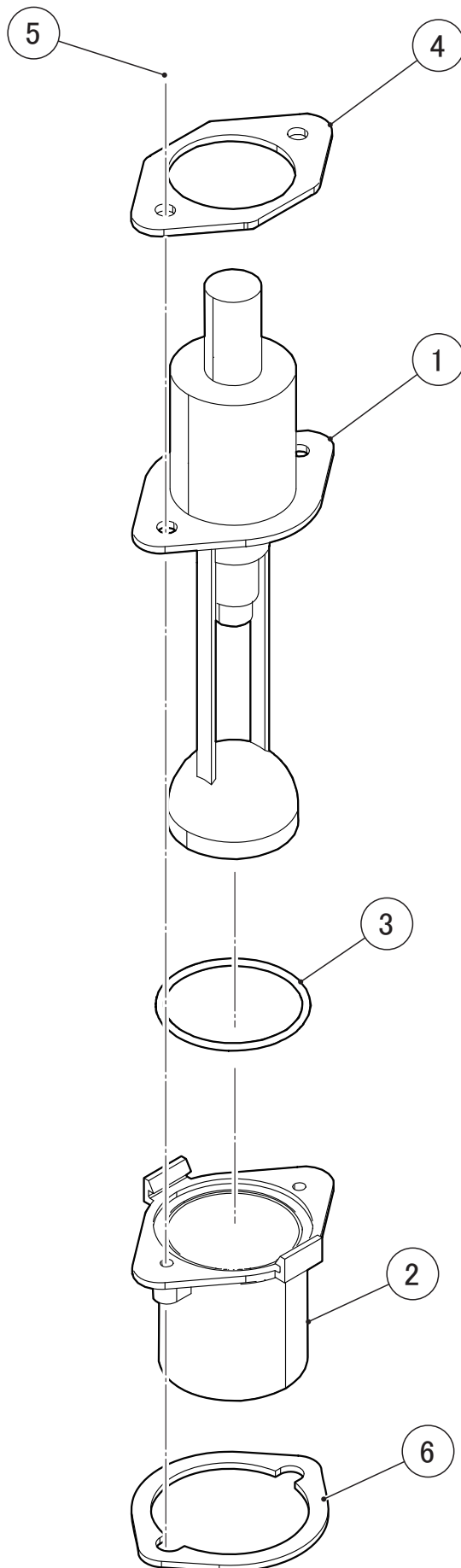

	No.4	No.6
Larger ice	2	0
Normal ice	1	1
Small ice	0	2

* The above may be factory adjusted.
See service manual for details.

HA

MODEL: KMD-410MWJ		TITLE: K. FLOAT SW. ASSY						
INDEX NO.	DESCRIPTION	MATERIAL OR MODEL NUMBER	PART NUMBER	REQ'D NUMBER				
				H-1,L-0	L-1			
1	FLOAT SWITCH		P00816-01	1	1			
2	BRACKET - FLOAT SW.		258597P01	1	1			
3	PACKING		474862R01	1	1			
4	SPACER(A) - FLOAT SW.		485043P01	1	1			
5	T2 TRUSS HEAD SCREW		FST0412S0	2	2			
6	SPACER(B)-FLOAT SW		485044P01	1	1			

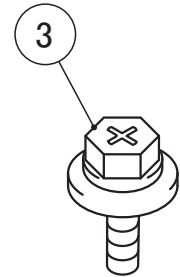
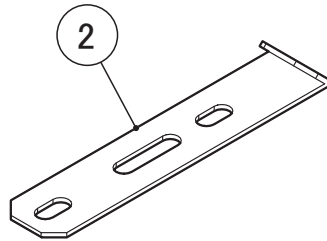
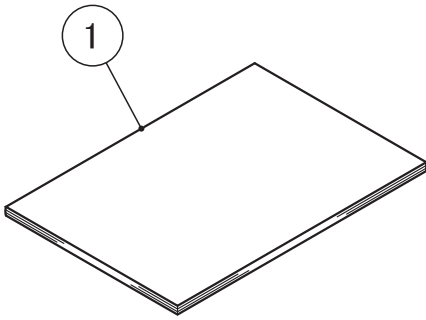

HA

MODEL: KMD-410MWJ		TITLE: L. ACCESSORIES						
INDEX NO.	DESCRIPTION	MATERIAL OR MODEL NUMBER	PART NUMBER	REQ'D NUMBER				
				H-1,L-0	L-1			
1	INSTRUCTION MANUAL		L1F129101	1	1			
2	UNIVERSAL BRACE		473048M01	2	2			
3	HEX HEAD BOLT W/WASHER [SW]		FBK0512S0	2	2			

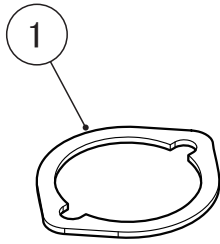

HA

MODEL: KMD-410MWJ		TITLE: M. OPTIONAL PARTS						
INDEX NO.	DESCRIPTION	MATERIAL OR MODEL NUMBER	PART NUMBER	REQ'D NUMBER				
				H-1,L-0	L-1			
1	SPACER(B)-FLOAT SW		485044P01	1	1			