

# Hoshizaki America, Inc.

## Modular Crescent Cuber

### Models

KM-46 IMAH

KM-46 IMWH

KM-46 IMRH



“A Superior Degree  
of Reliability”

[www.hoshizaki.com](http://www.hoshizaki.com)

## INSTRUCTION MANUAL



Issued: 2-13-2006  
Revised: 1-28-2008

## IMPORTANT

Only qualified service technicians should attempt to install, service, or maintain this icemaker. No installation, service, or maintenance should be undertaken until the technician has thoroughly read this Instruction Manual. Likewise, the owner/manager should not proceed to operate the icemaker until the installer has instructed them on its proper operation. Failure to install, operate, and maintain the equipment in accordance with this manual may adversely affect safety, performance, and warranty coverage.

HOSHIZAKI provides this manual primarily to assist qualified service technicians in the installation, maintenance, and service of the icemaker.

Should the reader have any questions or concerns which have not been satisfactorily addressed, please call, write, or send an e-mail message to the HOSHIZAKI Technical Support Department for assistance.

HOSHIZAKI AMERICA, INC.  
618 Highway 74 South  
Peachtree City, GA 30269

Attn: HOSHIZAKI Technical Support Department

Phone: 1-800-233-1940 Technical Service  
(770) 487-2331

Fax: 1-800-843-1056  
(770) 487-3360

E-mail: techsupport@hoshizaki.com

Web Site: [www.hoshizaki.com](http://www.hoshizaki.com)

**NOTE:** To expedite assistance, all correspondence/communication MUST include the following information:

- Model Number \_\_\_\_\_
- Serial Number \_\_\_\_\_
- Complete and detailed explanation of the problem.

## IMPORTANT

This manual should be read carefully before the icemaker is installed and operated. Only qualified service technicians should install, service, and maintain the icemaker. Read the warnings contained in this booklet carefully as they give important information regarding safety. Please retain this booklet for any further reference that may be necessary.

## CONTENTS

I. Specifications .....	4
A. Nameplate Rating .....	4
1. KM-461MAH (air-cooled).....	4
2. KM-461MWH (water-cooled).....	5
3. KM-461MRH (remote air-cooled) .....	6
B. Dimensions / Connections .....	7
1. KM-461MAH.....	7
2. KM-461MWH.....	8
3. KM-461MRH.....	9
II. Installation and Operating Instructions .....	10
A. Checks Before Installation .....	10
B. How to Remove Panels .....	10
C. Location .....	11
D. Setup .....	11
E. Electrical Connection .....	12
F. Installation of Remote Condenser Unit .....	13
1. Checks Before Installation.....	13
2. Location.....	13
3. Setup.....	14
4. Line Set .....	14
5. Electrical Connection.....	16
6. Stacking Remote Condenser Unit.....	16
G. Water Supply and Drain Connections .....	17
H. Final Checklist .....	19
I. Startup.....	20
III. Cleaning and Maintenance .....	21
A. Cleaning and Sanitizing Instructions.....	21
1. Cleaning Procedure.....	22
2. Sanitizing Procedure - Following Cleaning Procedure .....	23
B. Maintenance .....	24
C. Preparing the Icemaker for Long Storage .....	24

# I. Specifications

## A. Nameplate Rating

### 1. KM-461MAH (air-cooled)

<b>HOSHIZAKI ICE MAKER</b>	
MODEL NUMBER	KM-461MAH
SERIAL NUMBER	
AC SUPPLY VOLTAGE	115-120/60/1
COMPRESSOR	115-120V 10.6RLA 51LRA
PUMP	120V 0.5FLA 10W
FAN	120V 0.85FLA 50W
OTHER	115-120V 0.15A
MAXIMUM FUSE SIZE	20 AMPS
MAX. HACR BREAKER (USA ONLY)	20 AMPS
MAX. CIRC. BREAKER (CANADA ONLY)	20 AMPS
MINIMUM CIRCUIT AMPACITY	20 AMPS
DESIGN PRESSURE	HI-467PSI LO-206PSI
REFRIGERANT	404A 1 LB 12 OZ

**MOTOR-COMPRESSOR THERMALLY PROTECTED,  
NOT INTENDED FOR OUTDOOR USE!**

**Hoshizaki America, Inc.**  
Peachtree City, GA  
[www.hoshizaki.com](http://www.hoshizaki.com)



LISTED  
ICE MAKER  
WITHOUT  
STORAGE  
MEANS  
946Z





COMPONENT



PERFORMANCE  
CERTIFIED

See the nameplate for electrical and refrigeration specifications. This nameplate is located on the rear panel.

Since this nameplate is located on the rear panel of the icemaker, it cannot be read when the back of the icemaker is against a wall or against another piece of kitchen equipment. Therefore, the necessary electrical and refrigeration information is also on the rating label, which can be easily seen by removing only the front panel of the icemaker.

We reserve the right to make changes in specifications and design without prior notice.

## 2. KM-461MWH (water-cooled)

<b>HOSHIZAKI ICE MAKER</b>	
MODEL NUMBER	KM-461MWH
SERIAL NUMBER	
AC SUPPLY VOLTAGE	115-120/60/1
COMPRESSOR	115-120V 9.4RLA 51LRA
PUMP	120V 0.5FLA 10W
FAN	---
OTHER	115-120V 0.15A
MAXIMUM FUSE SIZE	20 AMPS
MAX. HACR BREAKER (USA ONLY)	20 AMPS
MAX. CIRC. BREAKER (CANADA ONLY)	20 AMPS
MINIMUM CIRCUIT AMPACITY	20 AMPS
DESIGN PRESSURE	HI-427PSI LO-206PSI
REFRIGERANT	404A 1 LB 1 OZ

**MOTOR-COMPRESSOR THERMALLY PROTECTED,  
NOT INTENDED FOR OUTDOOR USE!**

**Hoshizaki America, Inc.**  
Peachtree City, GA  
[www.hoshizaki.com](http://www.hoshizaki.com)



LISTED  
ICE MAKER  
WITHOUT  
STORAGE  
MEANS  
946Z





NSF  
COMPONENT



ARI  
PERFORMANCE  
CERTIFIED

See the nameplate for electrical and refrigeration specifications. This nameplate is located on the rear panel.

Since this nameplate is located on the rear panel of the icemaker, it cannot be read when the back of the icemaker is against a wall or against another piece of kitchen equipment. Therefore, the necessary electrical and refrigeration information is also on the rating label, which can be easily seen by removing only the front panel of the icemaker.

We reserve the right to make changes in specifications and design without prior notice.

### 3. KM-461MRH (remote air-cooled)

<b>HOSHIZAKI ICE MAKER</b>	
MODEL NUMBER	KM-461MRH
SERIAL NUMBER	
AC SUPPLY VOLTAGE	115-120/60/1
COMPRESSOR	115-120V 10.6RLA 51LRA
PUMP	120V 0.5FLA 10W
FAN REMOTE	120V 3A MAX
OTHER	115-120V 0.9A
MAXIMUM FUSE SIZE	20 AMPS
MAX. HACR BREAKER (USA ONLY)	20 AMPS
MAX. CIRC. BREAKER (CANADA ONLY)	20 AMPS
MINIMUM CIRCUIT AMPACITY	20 AMPS
DESIGN PRESSURE	HI-467PSI LO-206PSI
REFRIGERANT	404A

**MOTOR-COMPRESSOR THERMALLY PROTECTED,  
NOT INTENDED FOR OUTDOOR USE!**

**Hoshizaki America, Inc.**  
Peachtree City, GA  
[www.hoshizaki.com](http://www.hoshizaki.com)



LISTED  
ICE MAKER  
WITHOUT  
STORAGE  
MEANS  
946Z





COMPONENT



PERFORMANCE  
CERTIFIED

See the nameplate for electrical and refrigeration specifications. This nameplate is located on the rear panel.

Since this nameplate is located on the rear panel of the icemaker, it cannot be read when the back of the icemaker is against a wall or against another piece of kitchen equipment. Therefore, the necessary electrical and refrigeration information is also on the rating label, which can be easily seen by removing only the front panel of the icemaker.

We reserve the right to make changes in specifications and design without prior notice.

## B. Dimensions / Connections

### 1. KM-461MAH

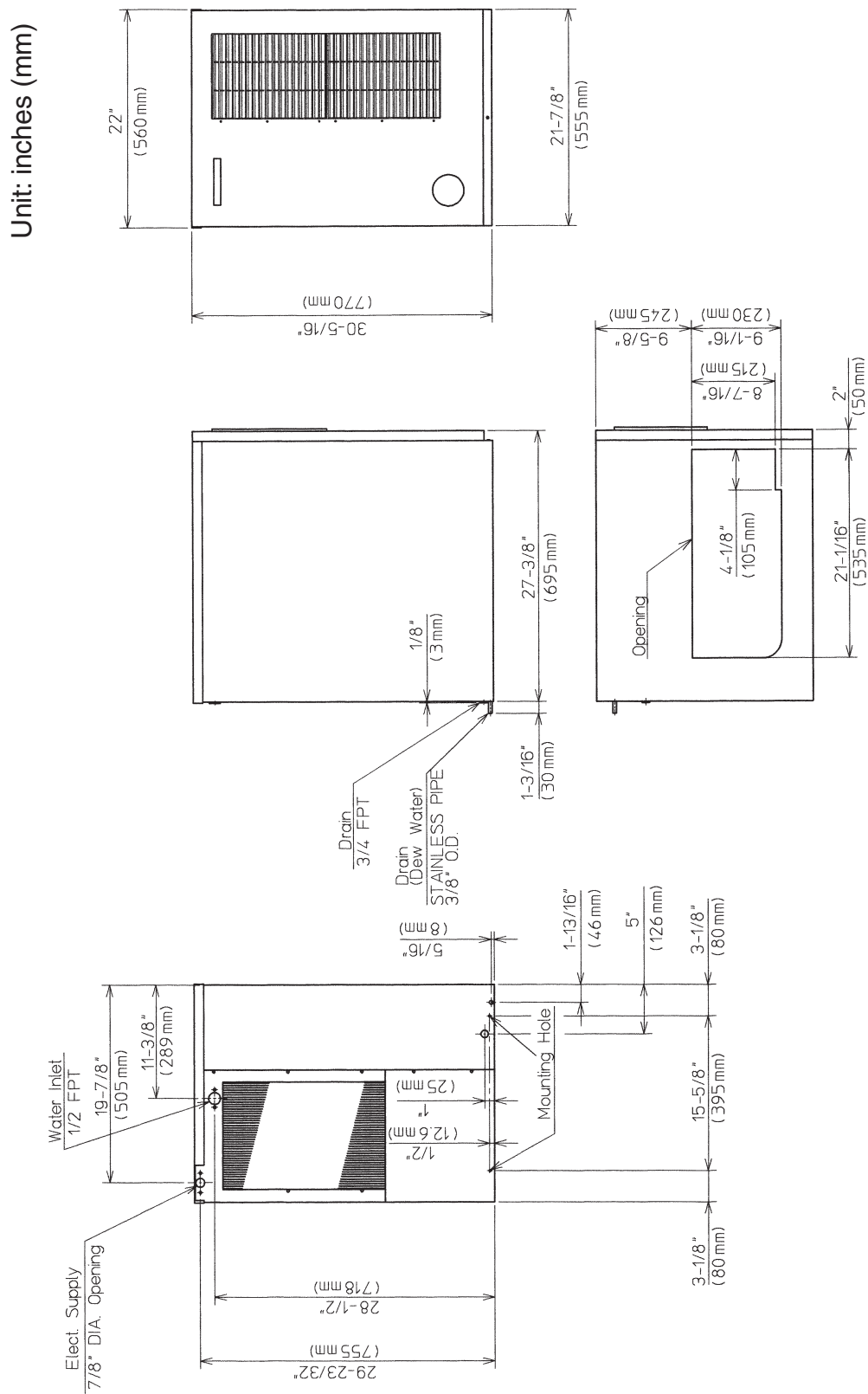

## 2. KM-461MWH

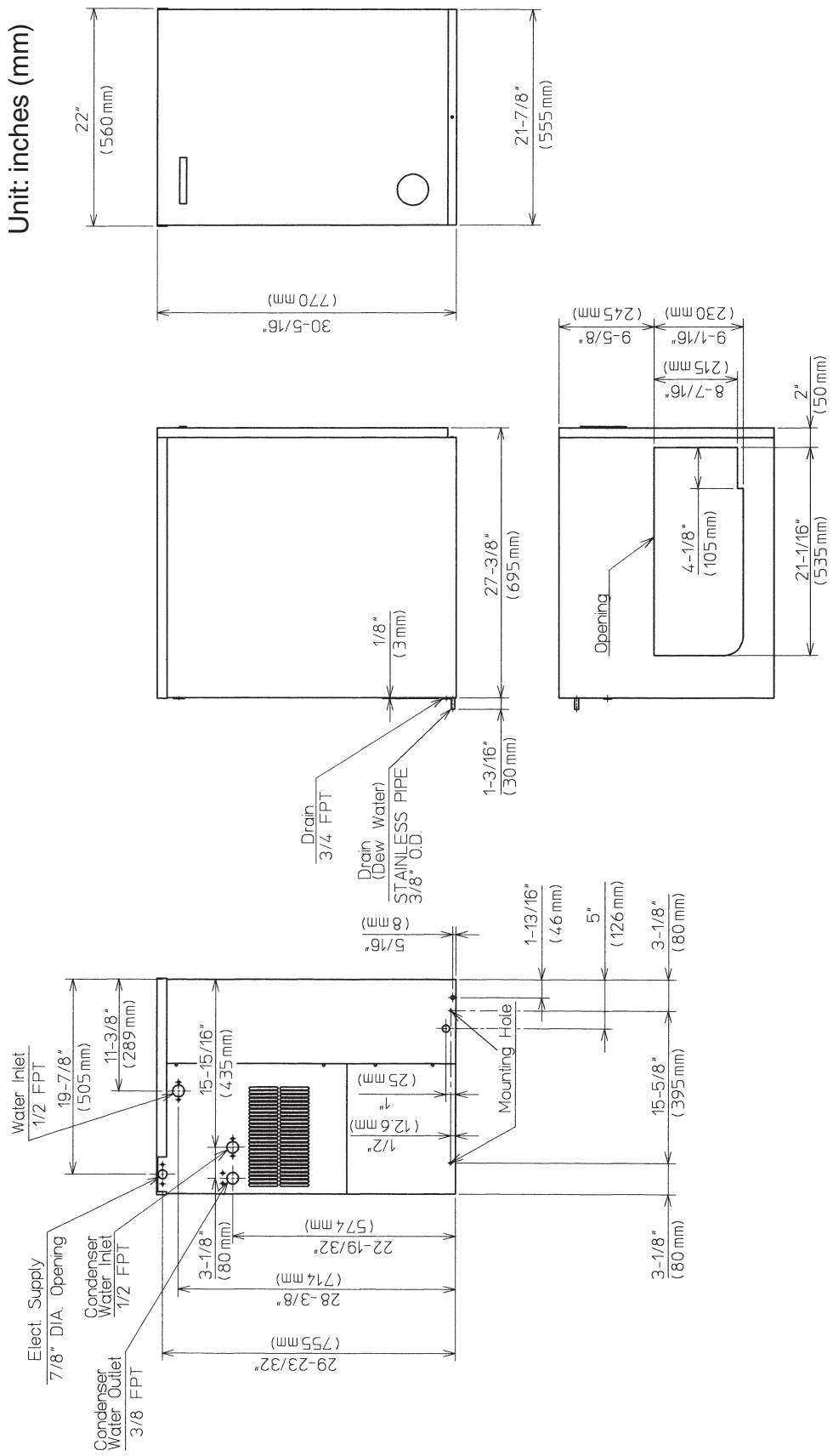



### 3. KM-461MRH

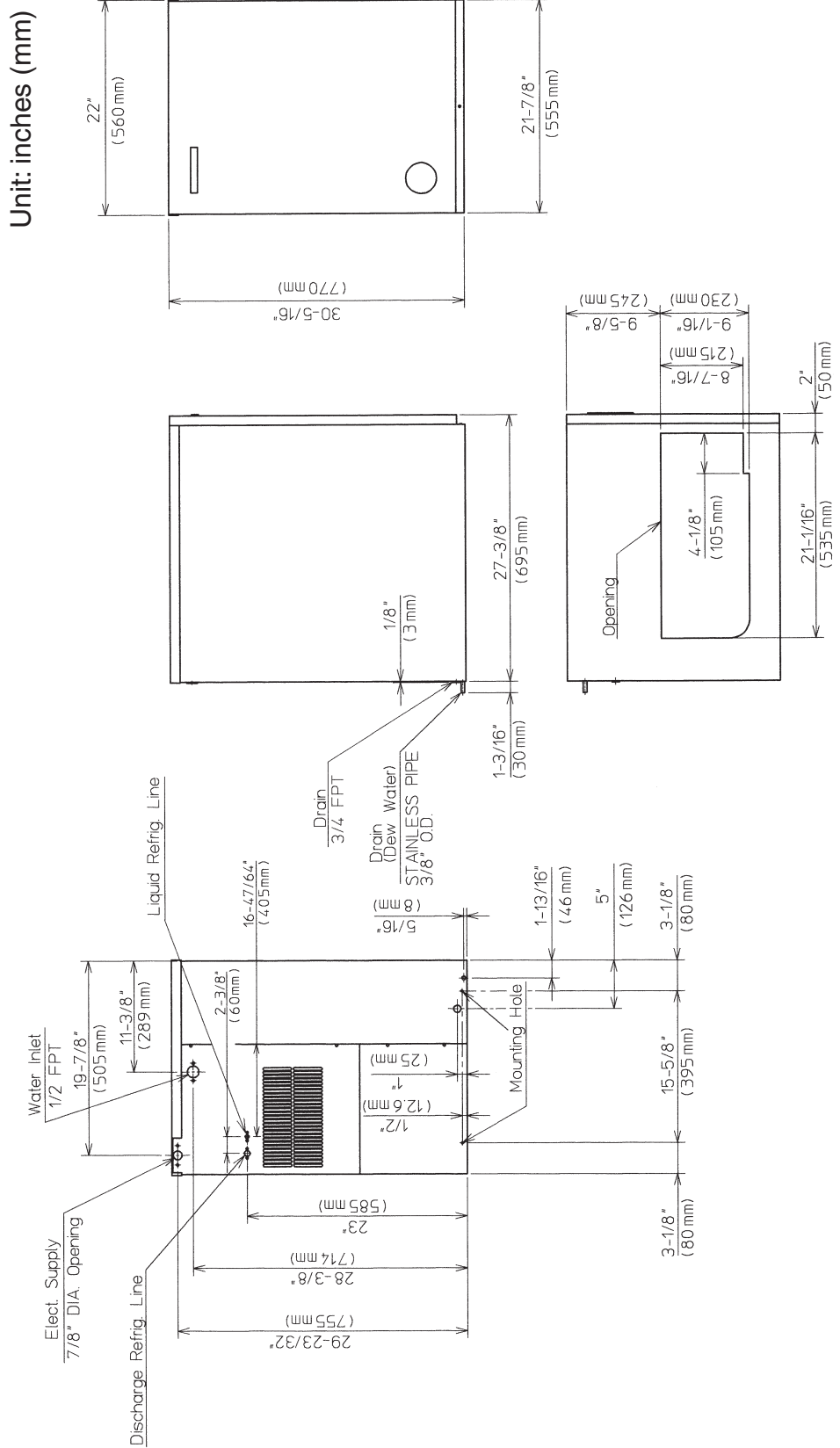

---

## II. Installation and Operating Instructions

### A. Checks Before Installation

#### IMPORTANT

1. Install in accordance with all applicable national, state, and local regulations.
2. Remove the shipping carton, tape, and packing material. If any are left in the icemaker, it will not work properly.
3. Ensure all components, fasteners, and thumbscrews are securely in place after installation.

- 1) Remove the panels to prevent damage when installing the icemaker. See "II.B. How to Remove Panels."
- 2) Remove the package containing the accessories.
- 3) Remove the protective plastic film from the panels. If the icemaker is exposed to the sun or to heat, remove the film after the icemaker cools.
- 4) Check that the refrigerant lines do not rub or touch lines or other surfaces, and that the fan blade (if applicable) turns freely.
- 5) Check that the compressor is snug on all mounting pads.
- 6) See the nameplate on the rear panel, and check that your voltage supplied corresponds with the voltage specified on the nameplate.
- 7) This icemaker needs a storage bin. The recommended storage bin is HOSHIZAKI ICE STORAGE BIN, Model B-300 series.
- 8) On remote air-cooled models, a remote condenser unit is needed. The recommended remote condenser unit is HOSHIZAKI REMOTE CONDENSER UNIT, Model URC-5F.

### B. How to Remove Panels See Fig. 1

- Front Panel: Remove the screw. Lift up and towards you.
- Top Panel: Lift up at front slightly, push rearward, and lift off.
- Side Panel (R): Remove the screw. Slide forward slightly, and lift off.
- Insulation Panel: Lift up slightly, and pull towards you.
- Base Cover: Lift up slightly, and pull towards you.

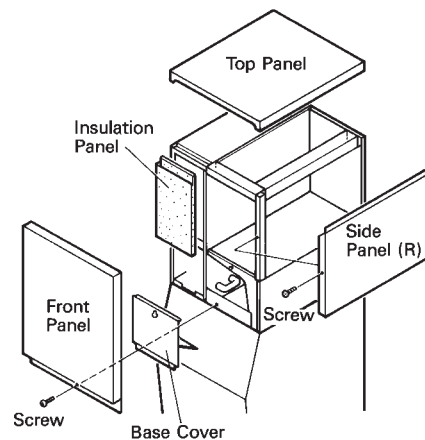

**Fig. 1**

## C. Location

### CAUTION

1. This icemaker is not intended for outdoor use. Normal operating ambient temperature should be within +45°F to +100°F (+7°C to +38°C); Normal operating water temperature should be within +45°F to +90°F (+7°C to +32°C). Operation of the icemaker, for extended periods, outside of these normal temperature ranges may affect icemaker performance.
2. This icemaker will not work at sub-freezing temperatures. To prevent damage to the water supply line, drain the icemaker if the air temperature is going to go below 32°F (0°C). See "III.C. Preparing the Icemaker for Long Storage."

For best operating results:

- Icemaker should not be located next to ovens, grills, or other high heat producing equipment.
- Avoid choosing a site where dripping is not allowed.
- Allow 6" (15 cm) clearance at rear, sides, and top for proper air circulation and ease of maintenance and/or service should they be required.
- Location should provide a firm and level foundation for the equipment.

## D. Setup

- 1) Unpack the storage bin, and attach the 4 adjustable legs provided (bin accessory) to the bottom of the storage bin.
- 2) Position the storage bin in the selected permanent location.
- 3) Place the icemaker on top of the storage bin.
- 4) Secure the icemaker to the storage bin using the 2 mounting brackets and the bolts provided. See Fig. 2.
- 5) Level the icemaker and storage bin in both the left-to-right and front-to-rear directions. Adjust the storage bin legs to make the icemaker level.
- 6) Replace the panels in their correct positions.

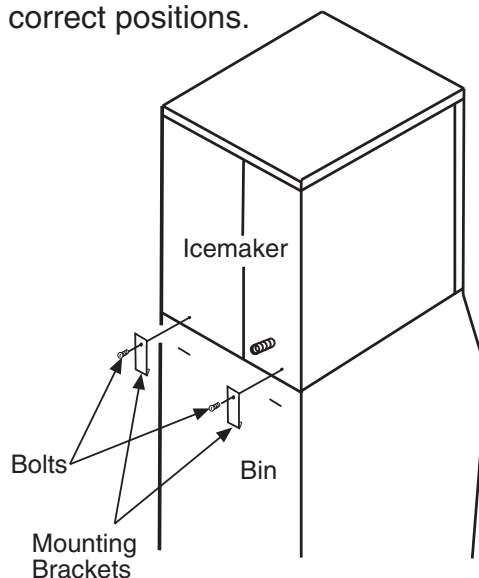

Fig. 2

## E. Electrical Connection

### WARNING

1. Electrical connection must be made in accordance with the instructions on the "WARNING" tag, provided with the pig tail leads in the junction box.
2. Electrical connections must meet national, state, and local electrical code requirements. Failure to meet these code requirements could cause severe injury to individuals or extensive damage to equipment.
3. Be sure to install a proper ground to the icemaker.

- Electrical connections must be installed in accordance with applicable national, state, and local regulations.
- The icemaker requires an independent power supply. See the nameplate for proper voltage and breaker/fuse size.
- The maximum allowable voltage variation is  $\pm 10$  percent of the nameplate rating.
- The white lead must be connected to the neutral conductor of the power source. Miswiring results in severe damage to the icemaker. See Fig. 3.
- The opening for the power supply connection is 7/8" DIA to fit a 1/2" trade size conduit.
- Usually an electrical permit and services of a licensed electrician are required.

## WARNING

### ELECTRICAL CONNECTION

The white lead must be connected to the neutral conductor of the power source. Miswiring results in severe damage to the icemaker. (See Fig. below)

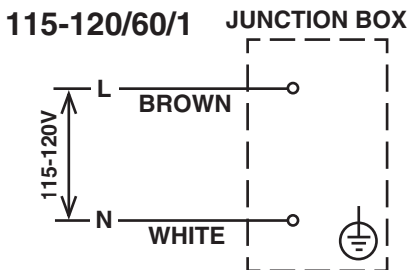

**Fig. 3**

## F. Installation of Remote Condenser Unit

### 1. Checks Before Installation

- 1) Remove the shipping carton, tape, and packing material.
- 2) Check that the refrigerant lines do not rub or touch lines or other surfaces, and that the fan blade moves freely.

### 2. Location

#### IMPORTANT

The remote condenser unit is intended for outdoor use. Normal operating ambient temperature should be within  $-20^{\circ}\text{F}$  to  $+122^{\circ}\text{F}$  ( $-29^{\circ}\text{C}$  to  $+50^{\circ}\text{C}$ ). Operation of the remote condenser unit, for extended periods, outside of this normal temperature range may affect icemaker performance.

The remote condenser unit must be positioned in a permanent site under the following guidelines:

- A firm and flat site.
- A dry and well ventilated area with 24" (61 cm) clearance in both front and rear for ease of maintenance and service should they be required.
- The maximum line length for the standard refrigerant charge is 66 feet. Should an installation require a longer line length, line sizes must be increased and additional refrigerant must be added. Instead of the standard 3/8" OD discharge line and 1/4" OD liquid line for this icemaker, increase the line sizes to 1/2" OD discharge line and 3/8" OD liquid line for the entire run. Add 16.5 oz. of R-404A to the system to compensate for the larger diameter line sizes, then additional refrigerant must be added. Add .4 oz. of R-404A for each foot over 66 feet to a maximum of 100 feet or call Hoshizaki Technical Support at 1-800-233-1940 for recommendations.
- The maximum vertical distance between the remote condenser unit and the icemaker is 33 feet above or 10 feet below the icemaker. These distances are measured fitting to fitting.

#### CAUTION

Failure to install the equipment within these guidelines may adversely affect performance, component life, and warranty coverage.

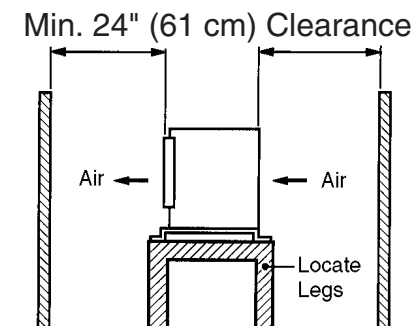
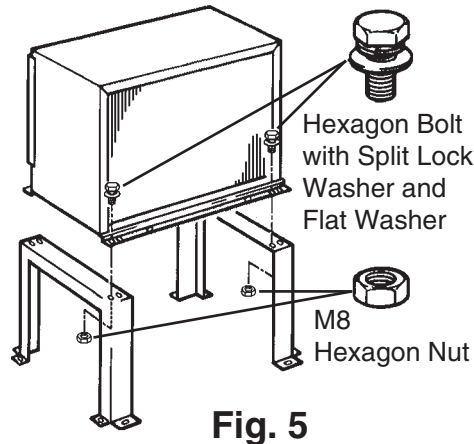

Fig. 4

### 3. Setup

- 1) Secure the legs to the remote condenser unit with eight M8×16 mm hexagon bolts and M8 nuts as shown in the illustration. See Fig. 5.
- 2) The legs have 8 mounting holes. Secure the legs with 8 bolts (not included).



**Fig. 5**

### 4. Line Set

- Precharged tubing kits, available as optional equipment from HOSHIZAKI AMERICA, are recommended. Field fabricated line sets are allowed, see instructions below.
- The maximum line length for the standard refrigerant charge is 66 feet. Should an installation require a longer line length, line sizes must be increased and additional refrigerant must be added. Instead of the standard 3/8" OD discharge line and 1/4" OD liquid line for this icemaker, increase the line sizes to 1/2" OD discharge line and 3/8" OD liquid line for the entire run. Add 16.5 oz. of R-404A to the system to compensate for the larger diameter line sizes, then additional refrigerant must be added. Add .4 oz. of R-404A for each foot over 66 feet to a maximum of 100 feet or call Hoshizaki Technical Support at 1-800-233-1940 for recommendations.
- The maximum vertical distance between the remote condenser unit and the icemaker is 33 feet above or 10 feet below the icemaker. These distances are measured fitting to fitting.

### **CAUTION**

Failure to install the equipment within these guidelines may adversely affect performance, component life, and warranty coverage.

## Factory Line Set Installation

- 1) Route the factory line set (3/8" OD discharge line and 1/4" OD liquid line) from the remote condenser unit to the icemaker. See Fig. 6. Factory fabricated line sets are precharged and do not need to be evacuated.

Note: Care should be taken that the icemaker, line set, and remote condenser unit contain the same type of refrigerant prior to making connections. Mixing of refrigerants will result in improper operation and possible damage to the refrigeration system.

- 2) Attach the refrigerant lines to the appropriate male couplings on the remote condenser unit first and then at the icemaker. Apply two drops of POE oil to the male threads of the couplings before tightening.
- 3) Tighten the couplings 1/4 turn beyond fully seated. A backup wrench is recommended.

## Field Fabricated Line Set Installation

- 1) Route a 3/8" OD copper tubing discharge line and a 1/4" OD copper tubing liquid line between the remote condenser unit and the icemaker. See Fig. 6.
- 2) Insulate the two copper tubings separately.
- 3) Install Parker quick connect couplings on each end. OS-QUICK, a universal quick connect coupling kit available as optional equipment from HOSHIZAKI AMERICA, is recommended.
- 4) Evacuate through the charging ports on the Parker quick connect couplings and charge with R-404A refrigerant vapor to a pressure of 15 to 30 PSIG.

Note: Care should be taken that the icemaker, line set, and remote condenser unit contain the same type of refrigerant prior to making connections. Mixing of refrigerants will result in improper operation and possible damage to the refrigeration system.

- 5) Attach the refrigerant lines to the appropriate male couplings on the remote condenser unit first and then at the icemaker. Apply two drops of POE oil to the male threads of the couplings before tightening.
- 6) Tighten the couplings 1/4 turn beyond fully seated. A backup wrench is recommended.

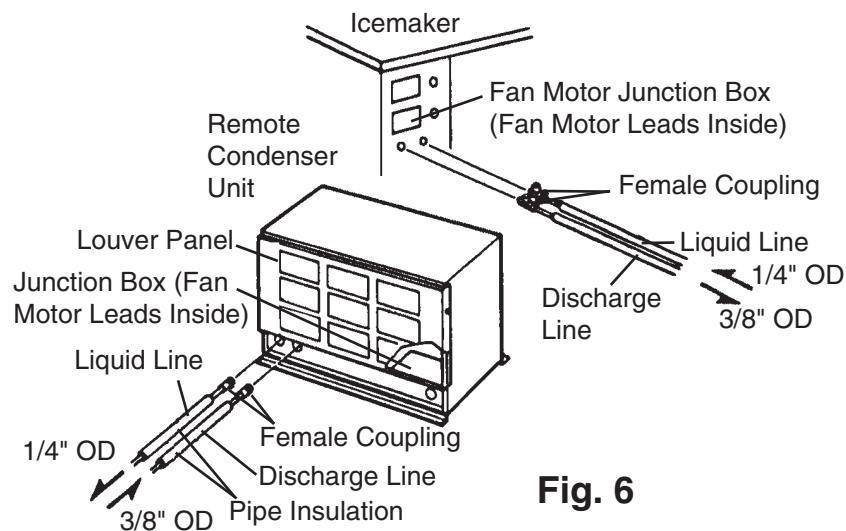

**Fig. 6**

## 5. Electrical Connection

### WARNING

1. Electrical connections must meet national, state, and local electrical code requirements. Failure to meet these code requirements could cause severe injury to individuals or extensive damage to equipment.
2. Be sure to install a proper ground from the icemaker to the remote condenser unit.

- This remote condenser unit must be connected to the fan motor junction box on the icemaker.
  - The opening for the power supply connection is 7/8" DIA to fit a 1/2" trade size conduit.
  - Usually an electrical permit and services of a licensed electrician are required.
- 1) Remove the louver panel. See Fig. 7.
  - 2) Remove the junction box cover on the remote condenser unit. Remove the fan motor junction box cover on the icemaker.
  - 3) Install a ground wire from the icemaker to the remote condenser unit.
  - 4) Connect the fan motor leads in the junction box of the remote condenser unit to the fan motor leads in the fan motor junction box of the icemaker.
  - 5) Replace the junction box covers and the louver panel in their correct positions.

## 6. Stacking Remote Condenser Unit

- 1) Install the lower remote condenser unit as described earlier in this section.
- 2) Place the upper remote condenser unit on top of the lower. See Fig. 8.
- 3) Secure the upper remote condenser unit with the 4 screws provided.
- 4) Install refrigerant lines, and make electrical connections for each fan motor as described earlier in this section.

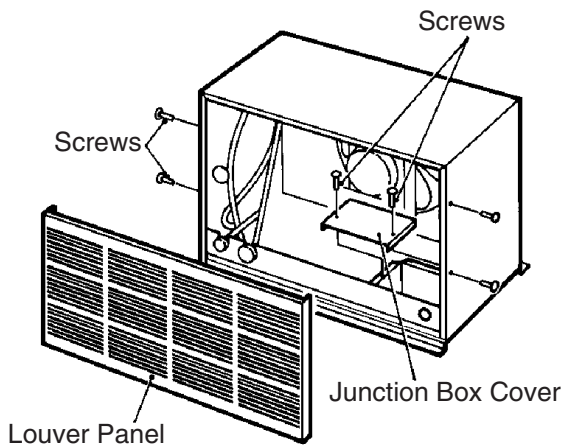

**Fig. 7**

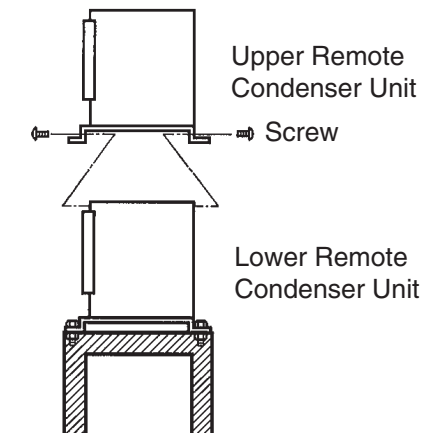

**Fig. 8**



## G. Water Supply and Drain Connections

See Fig. 9

### CAUTION

To prevent damage to equipment, do not operate the icemaker when the water supply is off, or if the pressure is below 10 PSIG. Do not run the icemaker until the proper water pressure is reached.

- Water supply inlet is 1/2" female pipe thread (FPT).  
Note: On water-cooled model, two 1/2" water supply inlets are provided. One is for the icemaker, and the other is for the water-cooled condenser.
- A water supply line shut-off valve and drain valve should be installed. A minimum of 3/8" OD copper tubing is recommended for the water supply lines.
- Water supply pressure should be a minimum of 10 PSIG and a maximum of 113 PSIG. If the pressure exceeds 113 PSIG, the use of a pressure reducing valve is required.
- The minimum recommended drain line is 3/4" OD hard pipe.
- Icemaker drain outlet is 3/4" FPT. Condensation drain outlet is a 3/8" OD stainless tube. The icemaker and condensation drain line(s) must be run separately from the storage bin drain line.  
Note: Water-cooled model also has a 3/8" FPT condenser drain outlet. Drain line must be run separately.
- Drain lines must have 1/4" fall per foot (2 cm per 1 m) on horizontal runs to get a good flow. A vented tee connection is also required for proper flow.
- Drain lines should not be piped directly to the sewer system. An air gap of a minimum of 2 vertical inches (5 cm) should be between the end of the drain pipes from the icemaker, the condensation drain, the storage bin, and the water-cooled condenser (if applicable) and the floor drain.
- This icemaker must be installed in accordance with applicable national, state, and local regulations.
- A plumbing permit and services of a licensed plumber may be required in some areas.
- Water-Cooled Model Only: In some areas, a back flow preventer may be required in the cooling water circuit.

**KM-461MAH  
KM-461MRH**

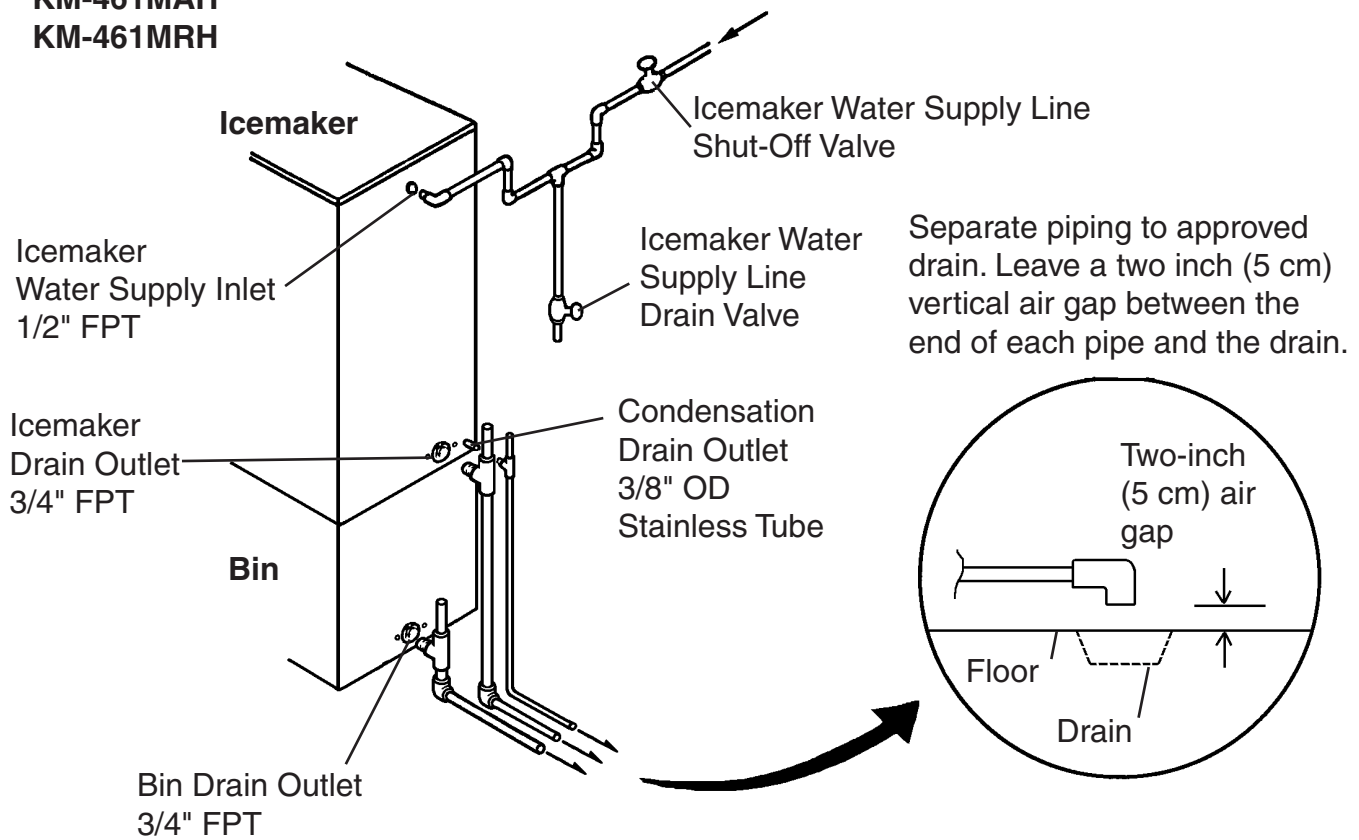

**KM-461MWH**

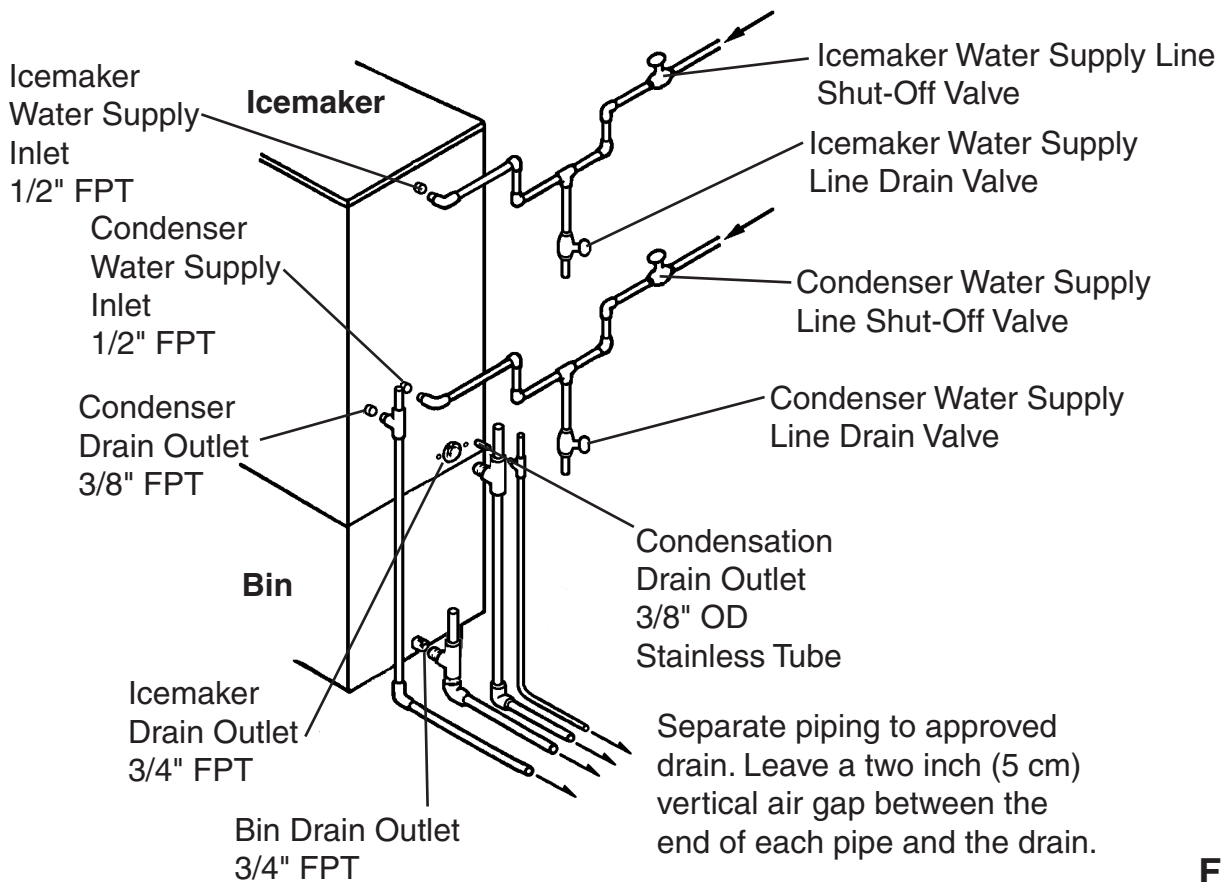

**Fig. 9**

## H. Final Checklist

- 1) Is the icemaker level?
- 2) Is the icemaker in a site where the ambient temperature is within +45°F to +100°F (+7°C to +38°C) and the water temperature within +45°F to +90°F (+7°C to +32°C) all year around?
- 3) Is there at least 6" (15 cm) clearance around the icemaker for maintenance or service?
- 4) Have the shipping carton, tape, and packing material been removed from the icemaker? Is the cube guide in the correct position?
- 5) Are all components, fasteners, and thumbscrews securely in place?
- 6) Have all electrical and piping connections been made?
- 7) Has the power supply voltage been checked or tested against the nameplate rating? Has a proper ground been installed to the icemaker? On remote air-cooled model, has a proper ground also been installed to the remote condenser unit?
- 8) Are the water supply line shut-off valve and drain valve installed? Has the water supply pressure been checked to ensure a minimum of 10 PSIG and a maximum of 113 PSIG?  
Note: The icemaker may stop running when the water supply is off, or if the pressure is below 10 PSIG. When the proper water pressure is reached, the icemaker automatically starts running again.
- 9) Are the compressor hold-down bolts snug? Have the refrigerant lines been checked to make sure they do not rub or touch other lines or surfaces?
- 10) Has the bin control switch been checked for correct operation? When the icemaker is running, hold an ice cube in contact with the bulb. The icemaker should stop within 3 to 10 seconds. Adjustment may be needed, particularly at higher altitude locations.
- 11) Has the end user been given the instruction manual, and instructed on how to operate the icemaker and the importance of the recommended periodic maintenance?
- 12) Has the end user been given the name and telephone number of an authorized service agent?
- 13) Has the warranty card been filled out and forwarded to the factory for warranty registration?

## I. Startup

### CAUTION

1. All parts are factory-adjusted. Improper adjustments may result in failure.
2. If the icemaker is turned off, wait for at least 3 minutes before restarting the icemaker to prevent damage to the compressor.
3. Do not operate the icemaker in the "WASH" position without water in the water tank. This will cause damage to the water pump seal.

- 1) Open the water supply line shut-off valve.
- 2) Remove the front panel.
- 3) Move the control switch on the control box to the "ICE" position.
- 4) Replace the front panel in its correct position.
- 5) Turn on the power supply, and allow the icemaker to operate for a total of 10 minutes.
- 6) Turn off the power supply, and remove the front panel and the base cover.
- 7) Remove one end of the pump tubing to drain the water tank. See Fig. 10.
- 8) After the water tank has drained, replace the pump tubing in its correct position.
- 9) Clean the storage bin liner using a neutral cleaner. Rinse thoroughly after cleaning.
- 10) Replace the base cover and the front panel in their correct positions.
- 11) Turn on the power supply to start the automatic icemaking process.

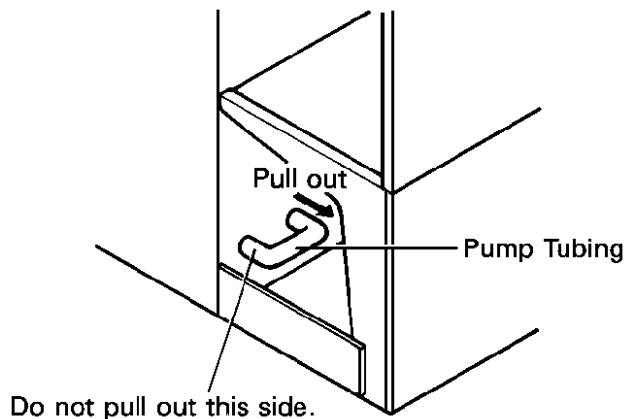

**Fig. 10**

### III. Cleaning and Maintenance

#### IMPORTANT

Ensure all components, fasteners, and thumbscrews are securely in place after any cleaning or maintenance is done to the equipment.

#### A. Cleaning and Sanitizing Instructions

#### WARNING

1. HOSHIZAKI recommends cleaning this icemaker at least once a year. More frequent cleaning, however, may be required in some existing water conditions.
2. To prevent injury to individuals and damage to the icemaker, do not use ammonia type cleaners.
3. Always wear liquid-proof gloves to prevent the cleaning and sanitizing solutions from coming into contact with skin.
4. Carefully follow any instructions provided with the bottles of cleaning and sanitizing solution.
5. Never run the icemaker when the water tank is empty.

#### IMPORTANT

1. The cleaning valve is used to allow solution flow to the inside of the evaporator during the cleaning and sanitizing operation. It should be closed for all icemaking operation. The compressor will not operate unless this valve is completely closed.
2. To open the cleaning valve, the valve handle should be parallel to the valve body. To close the valve, the valve handle should be at a right angle to the valve body.

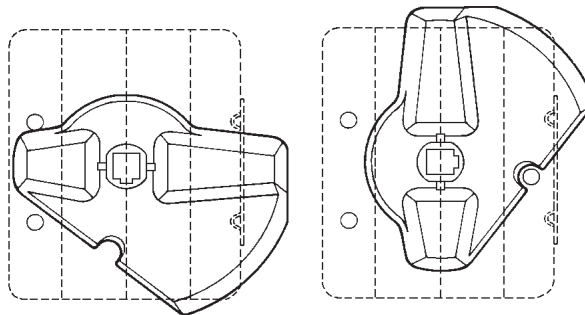

CLOSED POSITION

OPEN POSITION

## 1. Cleaning Procedure

- 1) Dilute 16 fl. oz. (473 ml) of recommended cleaner Hoshizaki "Scale Away" or "LIME-A-WAY" (Economics Laboratory, Inc.) with 3 gal. ( 11 l) of warm water.
- 2) Remove all ice from the evaporator and the storage bin.  
Note: To remove cubes on the evaporator, turn off the power supply and turn it back on after 3 minutes. The harvest cycle starts and the cubes will be removed from the evaporator.
- 3) Turn off the power supply.
- 4) Remove the front panel and the base cover, and then remove the insulation panel by lifting up the panel slightly and pulling it towards you.
- 5) Remove one end of the pump tubing. Drain the water tank. Replace the pump tubing in its correct position. See Fig. 10.
- 6) In bad or severe water conditions, clean the float switch assembly as described below. Otherwise, continue to step 7.
  - a. Disconnect the vent tube and the flush tube from the top of the float switch, then remove the float switch and rubber boot.
  - b. Remove the retainer rod from the bottom of the float switch assembly, then remove the float. Be careful not to bend the retainer rod excessively when removing it.
  - c. Wipe down the float switch assembly's housing, shaft, float, and retainer rod with cleaning solution. Clean the inside of the rubber boot and hose with cleaning solution. Rinse the parts thoroughly with clean water.
  - d. Reassemble the float switch assembly and replace it and the rubber boot in their correct positions. Reconnect the vent tube and the flush tube.
- 7) Pour the cleaning solution into the water tank.
- 8) Fully open the cleaning valve on the left side wall of the machine compartment.
- 9) Move the control switch on the control box to the "WASH" position.
- 10) Replace the insulation panel and the front panel in their correct positions.
- 11) Turn on the power supply to start the washing process.
- 12) Turn off the power supply after 30 minutes.
- 13) Remove the front panel.
- 14) Remove one end of the pump tubing. Drain the water tank. Replace the pump tubing in its correct position.
- 15) Move the control switch to the "ICE" position.
- 16) Close the cleaning valve.  
Note: The icemaker will not operate unless the cleaning valve is completely closed.
- 17) Replace the front panel in its correct position.
- 18) Turn on the power supply to fill the water tank with water.
- 19) Turn off the power supply after 3 minutes.
- 20) Remove the front panel and fully open the cleaning valve.
- 21) Move the control switch to the "WASH" position.

- 22) Replace the front panel in its correct position.
- 23) Turn on the power supply to rinse off the cleaning solution.
- 24) Turn off the power supply after 5 minutes.
- 25) Remove the front panel.
- 26) Remove one end of the pump tubing. Drain the water tank. Replace the pump tubing in its correct position.
- 27) Repeat steps 15 through 26 three more times to rinse thoroughly.  
Note: If you do not sanitize the icemaker, go to step 10 in "2. Sanitizing Procedure."

## **2. Sanitizing Procedure - Following Cleaning Procedure**

- 1) Dilute a 5.25% sodium hypochlorite solution (chlorine bleach) with warm water. (Add 1.5 fl. oz. (44 ml) of sanitizer to 3 gal. (11 l) of water.)
- 2) Remove the insulation panel.
- 3) Pour the sanitizing solution into the water tank.
- 4) Replace the insulation panel and the front panel in their correct positions.  
Note: Make sure that the control switch is in the "WASH" position and the cleaning valve is open.
- 5) Turn on the power supply to start the sanitizing process.
- 6) Turn off the power supply after 15 minutes.
- 7) Remove the front panel.
- 8) Remove one end of the pump tubing. Drain the water tank. Replace the pump tubing in its correct position.
- 9) Repeat steps 15 through 26 in "1. Cleaning Procedure" two times to rinse thoroughly.
- 10) Close the cleaning valve.
- 11) Move the control switch to the "ICE" position.
- 12) Replace the front panel and the base cover in their correct positions.
- 13) Clean the storage bin using a neutral cleaner. Rinse thoroughly after cleaning.
- 14) Turn on the power supply to start the automatic icemaking process.

## B. Maintenance

### IMPORTANT

This icemaker must be maintained individually, referring to the instruction manual and labels provided with the icemaker.

#### 1. Stainless Steel Exterior

To prevent corrosion, wipe the exterior occasionally with a clean, soft cloth. Use a damp cloth containing a neutral cleaner to wipe off oil or dirt build up.

#### 2. Storage Bin and Scoop

- Wash your hands before removing ice. Use the plastic scoop provided (bin accessory).
- The storage bin is for ice use only. Do not store anything else in the storage bin.
- Clean the scoop and the storage bin liner using a neutral cleaner. Rinse thoroughly after cleaning.

#### 3. Air Filters (air-cooled model only)

Plastic mesh air filters remove dirt and dust from the air, and keep the condenser from getting clogged. As the filters get clogged, the icemaker's performance will be reduced. Check the filters at least twice a month. When clogged, use warm water and a neutral cleaner to wash the filters.

#### 4. Condenser (air-cooled and remote air-cooled models only)

Check the condenser once a year, and clean the coil if required by using a brush or vacuum cleaner. More frequent cleaning may be required depending on location.

## C. Preparing the Icemaker for Long Storage

### CAUTION

When shutting off the icemaker for an extended time, drain out all water from the water tank and remove the ice from the storage bin. The storage bin should be cleaned and dried. Drain the icemaker to prevent damage to the water supply line at sub-freezing temperatures, using air or carbon dioxide. Shut off the icemaker until the proper ambient temperature is resumed.

When the icemaker is not used for two or three days, it is sufficient to only move the control switch to the "OFF" position, unless the icemaker will be at sub-freezing temperatures.

#### 1. On water-cooled model only, first remove the water from the water-cooled condenser:

- 1) Turn off the power supply and remove the front panel and right side panel.
- 2) Close the condenser water supply line shut-off valve. See Fig. 9.
- 3) Open the condenser water supply line drain valve.
- 4) Attach a compressed air or carbon dioxide supply to the condenser water supply line drain valve.
- 5) Open the water regulating valve by using a screwdriver to pry up on the spring retainer underneath the spring. While holding the valve open, blow out the condenser using the compressed air or carbon dioxide supply until water stops coming out.



- 6) Close the condenser water supply line drain valve and replace the right side panel in its correct position.

## **2. Remove the water from the icemaker water supply line:**

- 1) If you have not already done so, turn off the power supply and remove the front panel.
- 2) Close the icemaker water supply line shut-off valve and open the icemaker water supply line drain valve. See Fig. 9.
- 3) Allow the line to drain by gravity.
- 4) Attach a compressed air or carbon dioxide supply to the icemaker water supply line drain valve.
- 5) Make sure at least 3 minutes have elapsed since you turned off the power supply. Make sure the control switch is in the "ICE" position. Replace the front panel in its correct position and turn on the power supply.
- 6) Blow the icemaker water supply line out using the compressed air or carbon dioxide supply.
- 7) Close the icemaker water supply line drain valve.

## **3. Drain the water tank:**

- 1) Turn off the power supply and remove the front panel.
- 2) Move the control switch to the "OFF" position.
- 3) Remove the base cover.
- 4) Remove one end of the pump tubing. Drain the water tank. Replace the pump tubing in its correct position. See Fig. 10.
- 5) Remove all ice from the storage bin. Clean the storage bin using a neutral cleaner. Rinse thoroughly after cleaning.
- 6) Replace the front panel in its correct position.

**HOSHIZAKI AMERICA, INC.**

---

618 Hwy. 74 S., Peachtree City, GA 30269 USA | TEL (770) 487-2331 | FAX (770) 487-3360 | [www.hoshizaki.com](http://www.hoshizaki.com) | 91A1MK10D