



HOSHIZAKI

Parts List

Modular Crescent Cuber

Models

KM-350MAJ, MWJ

KM-420MAJ, MWJ, MRJZ

KM-520MAJ, MWJ, MRJ, MRJZ

KM-660MAJ, MWJ, MRJ, MRJZ



CONTENTS

Auxiliary Codes.....	3
A. Main Assembly and Refrigeration Circuit.....	6
KM-350MAJ, KM-420MAJ, KM-520MAJ, KM-660MAJ	6
KM-350MWJ, KM-420MWJ, KM-520MWJ, KM-660MWJ	9
KM-420MRJZ, KM-520MRJ(Z), KM-660MRJ(Z)	12
B. Water Circuit	14
C. Control Box Assembly	16
D. Accessories & Labels	19

Auxiliary Codes

KM-350MAJ

H-0 May 2018
J-0 January 2019
J-1 November 2019
K-0 January 2020
K-1 June 2020
K-2 October 2020
L-0 January 2021
L-1 September 2021
M-0 January 2022
M-1 August 2022
N-0 January 2023
P-0 January 2024
P-1 June 2024
P-2 July 2024
P-3 September 2024
P-4 November 2024

KM-350MWJ

H-0 May 2018
J-0 January 2019
J-1 November 2019
K-0 January 2020
K-1 October 2020
L-0 January 2021
L-1 September 2021
L-2 November 2022
M-0 February 2022
N-0 January 2023
P-0 April 2024
P-2 July 2024
P-3 September 2024

KM-420MAJ

M-0 May 2022
M-1 December 2022

KM-420MWJ

M-0 May 2022
M-1 December 2022

KM-420MRJZ

M-0 May 2022

KM-520MAJ

H-0 May 2018
J-0 January 2019
J-1 November 2019
K-0 January 2020
K-1 July 2020
K-2 October 2020
L-0 January 2021
M-0 February 2022
M-1 July 2022
M-2 September 2022
N-0 January 2023
P-0 January 2024
P-1 March 2024
P-2 June 2024
P-3 September 2024
P-4 October 2024

KM-520MWJ

H-0 May 2018
J-0 February 2019
J-1 November 2019
K-0 January 2020
K-1 October 2020
L-0 January 2021
L-1 November 2021
M-0 February 2022
N-0 January 2023
P-0 February 2024

KM-520MRJ

H-0 May 2018
J-0 January 2019
J-1 November 2019
K-0 February 2020
K-1 October 2020
L-0 January 2021

KM-520MRJZ

L-0 October 2021
L-1 November 2021
M-0 February 2022
N-0 January 2023
P-3 January 2024

Auxiliary Codes
continued

KM-660MAJ

H-0 May 2018
J-0 February 2019
J-1 November 2019
K-0 January 2020
K-1 July 2020
K-2 October 2020
L-0 January 2021
L-1 November 2021
M-0 January 2022
M-1 July 2022
M-2 September 2022
N-0 January 2023
P-0 January 2024
P-1 June 2024
P-2 July 2024
P-3 September 2024
P-4 October 2024

KM-660MWJ

H-0 May 2018
J-0 February 2019
J-1 November 2019
K-0 January 2020
K-1 October 2020
L-0 January 2021
L-1 November 2021
M-0 February 2022
M-1 July 2022
M-2 November 2022
N-0 March 2023
P-0 March 2024
P-2 July 2024
P-3 September 2024

KM-660MRJ

H-0 May 2018
J-0 January 2019
J-1 November 2019
K-0 February 2020
L-0 January 2021

KM-660MRJZ

L-0 October 2021
L-1 November 2021
M-0 February 2022
M-1 July 2022
M-2 October 2022
N-0 February 2023
P-0 January 2024
P-1 June 2024
P-2 July 2024

***K Control Board (2A8242-02) to K+ Control Board (2A9678-02) and
Ultrasonic Bin Control (4A6148G01) to Mechanical Bin Control (2A8598G01)**

Auxiliary Code Break

Control Board 2A9678-01

KM-350MAJ L19077K to L19236K

KM-520MAJ L02153K to L02411K

KM-660MAJ L05262K to L05441K

KM-660MWJ L00674K to L00693K

Mechanical Bin Control 2A8598G01

KM-350MAJ L19077K to L19236K

KM-520MAJ L02153K to L02411K

KM-660MAJ L05262K to L05441K

KM-660MWJ L00674K to L00693K

Auxiliary Code Breakdown

The auxiliary code is the first two characters in the serial number. The first character indicates the year. Years progress or regress in alphabetical order. The series runs from "A" through "V" and the letters "I" and "O" are skipped. The second character indicates significant part changes within a year. Base is "0" and this number advances for each change. In cases where there is a letter in parentheses, this designates the month. This is the last character in the serial number. The series runs from "(A)" through "(M)" and the letter "(I)" is skipped. This designation is only included when identifying a parts change within an auxiliary code.

Note About Ordering Parts

Most assemblies cannot be ordered as complete units; parts in the assemblies generally must be ordered separately.

A. Main Assembly and Refrigeration Circuit
KM-350MAJ, KM-420MAJ, KM-520MAJ, KM-660MAJ
H-0 to P-4

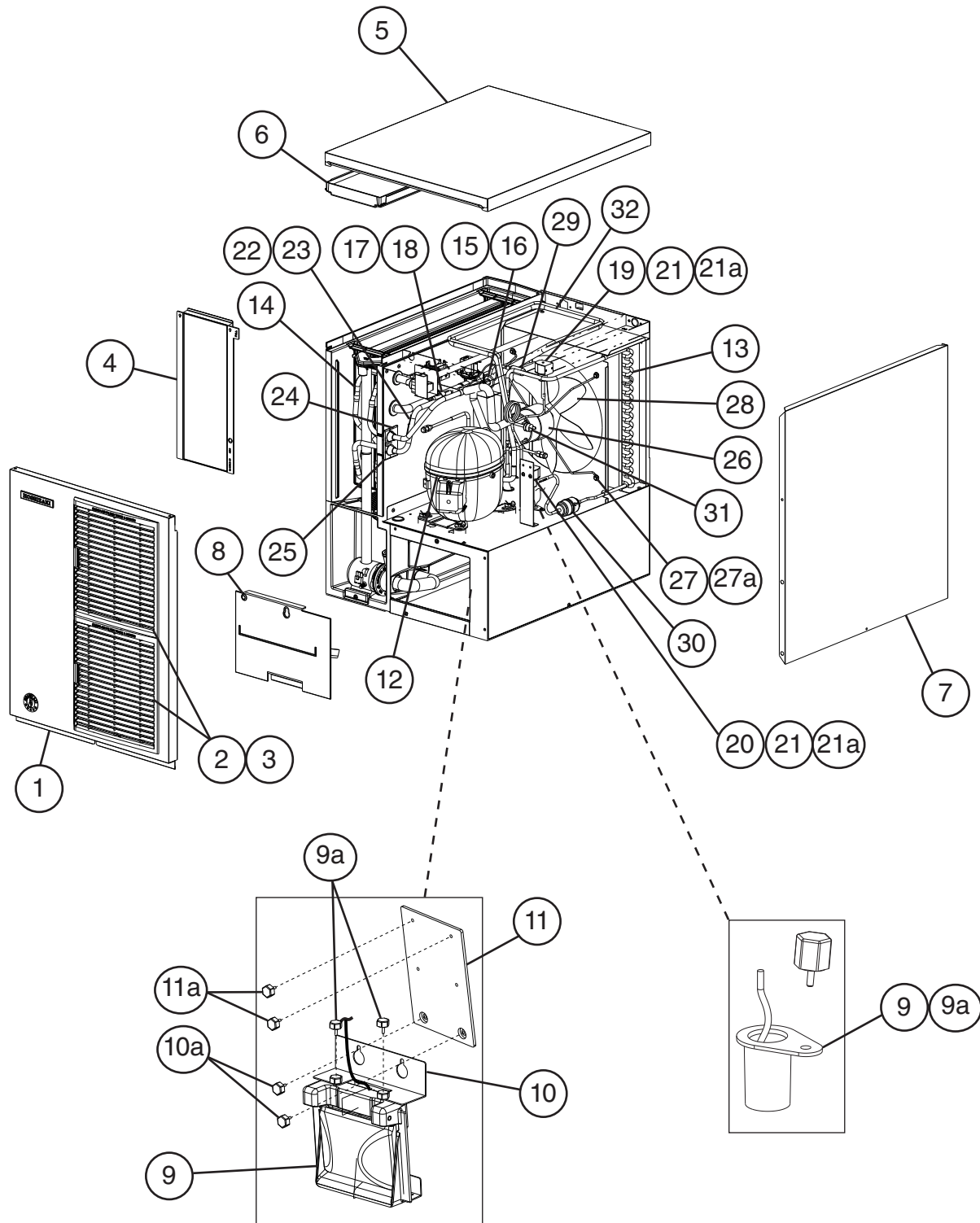

*See Page 5 for Serial Number Usage

Title: A. Main Assembly and Refrigeration Circuit Model: KM-350MAJ, KM-420MAJ, KM-520MAJ, KM-660MAJ												
Index No.	Description	Material or Model Number	Part Number	Required Number								
				H-0 to L-0 (K)	L-0 (L) to L-1 (J)	L-1 (K)	L-1 (L) to P-2	P-3	P-4			
Main Assembly												
1	Front Panel Assembly (includes items 2 and 3)		1A6184A01	1	1	1	1	1	1			
2	Louver Assembly (includes item 3)		2A6649A01	2	2	2	2	2	2			
3	Air Filter		2A2062G01	2	2	2	2	2	2			
4	Front Insulation		3A9354G01	1	1	1	1	1	1			
5	Top Panel Assembly	KM-350MAJ	1A5321G01	1	1	1	1	1	-			
			1A6550G01						1			
		KM-420MAJ	1A5321G01				1					
		KM-520MAJ KM-660MAJ	1A5321G01 1A6550G01	1 1	1 1	1 1	1 1	- 1	1 1			
6	Top Insulation		3A9353G01	1	1	1	1	1	1			
7	Right Side Panel		1A5480-01	1	1	1	1	1	1			
8	Base Cover		3A9771-01	1	1	1	1	1	1			
9	Ultrasonic Bin Control *See page 5 "Aux Code Break"	KM-350MAJ	4A6148G01	1	1	*1	1	1	1			
		KM-420MAJ					1					
		KM-520MAJ KM-660MAJ		*1	1	1	1	1	1			
	Mechanical Bin Control *See page 5 "Aux Code Break"	KM-350MAJ KM-520MAJ KM-660MAJ	2A8598G01			*1	-					
9a	Screw		7C32-0410	*1	1	*1	1	1	1			
	Thumbscrews		415949G08	*2		*2						
10	Mechanical Bin Control Bracket	KM-350MAJ	3A8283-01			*1	-					
		KM-520MAJ KM-660MAJ		*1	-							
10a	Thumbscrews	KM-350MAJ	415949G08			*2	-					
		KM-520MAJ KM-660MAJ		*2	-							
11	Mechanical Bin Control Extention Bracket (dispenser applications)	KM-350MAJ	4A5046G01			*1	-					
		KM-520MAJ KM-660MAJ		*1	-							
11a	Thumbscrews	KM-350MAJ	415949G08			*2	-					
		KM-520MAJ KM-660MAJ		*2	-							

Title: A. Main Assembly and Refrigeration Circuit				Model: KM-350MAJ, KM-420MAJ, KM-520MAJ, KM-660MAJ									
Index No.	Description	Material or Model Number	Part Number	Required Number									
				H-0 to L-0 (K)	L-0 (L) to L-1 (J)	L-1 (K)	L-1 (L) to P-2	P-3	P-4				
Refrigeration Circuit													
12	Compressor	KM-350MAJ	4A5090-01	1	1	1	1	1	1				
		KM-420MAJ	4A4479-01				1						
		KM-520MAJ	4A4479-01	1	1	1	1	1	1				
		KM-660MAJ	4A5158-01	1	1	1	1	1	1				
13	Condenser	KM-350MAJ	1A4582-01	1	1	1	1	1	1				
		KM-420MAJ	1A4584-01				1						
		KM-520MAJ	1A4584-02	1	1	1	1	1	1				
		KM-660MAJ											
14	Evaporator	All Except KM-420MAJ	1A4119G01	1	1	1	1	1	1				
		KM-420MAJ	1A4119G02				1						
15	Thermostatic Expansion Valve		4A4008-02	1	1	1	1	1	1				
16	Thermostatic Expansion Valve Cover		4A6853-01	1	1	1	1	1	1				
17	Thermostatic Expansion Valve Bulb Holder		3A0107-01	1	1	1	1	1	1				
18	Hose Clamp		443461-02	1	1	1	1	1	1				
19	Hot Gas Valve Body		4A3978-01	1	1	1	1	1	1				
20	Liquid Line Valve Body		4A3276-01	1	1	1	1	1	1				
21	Valve Coil		4A3277-01	2	2	2	2	2	2				
21a	Bolt		4A3277F01	2	2	2	2	2	2				
22	Thermistor		429006-03	1	1	1	1	1	1				
23	Thermistor Holder		427430-01	1	1	1	1	1	1				
24	Rubber Insulation A		3A9637-01	1	1	1	1	1	1				
25	Rubber Insulation B		3A9638-01	1	1	1	1	1	1				
26	Fan Motor		4A3158-01	1	1	1	1	1	1				
27	Fan Motor Bracket		2A9618-02	1	1	1	1	1	1				
27a	Hex Bolt	5x12, SS	7B0230516	4	4	4	4	4	4				
28	Fan Blade		4A0197-01	1	1	1	1	1	1				
29	Strainer		441569-04	1	1	1	1	1	1				
30	Drier		4A1113-01	1	1	1	1	1	1				
31	High-Pressure Switch		463180-01	1	1	1	1	1	1				
32	Heat Exchanger		2A9117G01	1	1	1	1	1	1				

A. Main Assembly and Refrigeration Circuit
KM-350MWJ, KM-420MWJ, KM-520MWJ, KM-660MWJ
H-0 to P-3

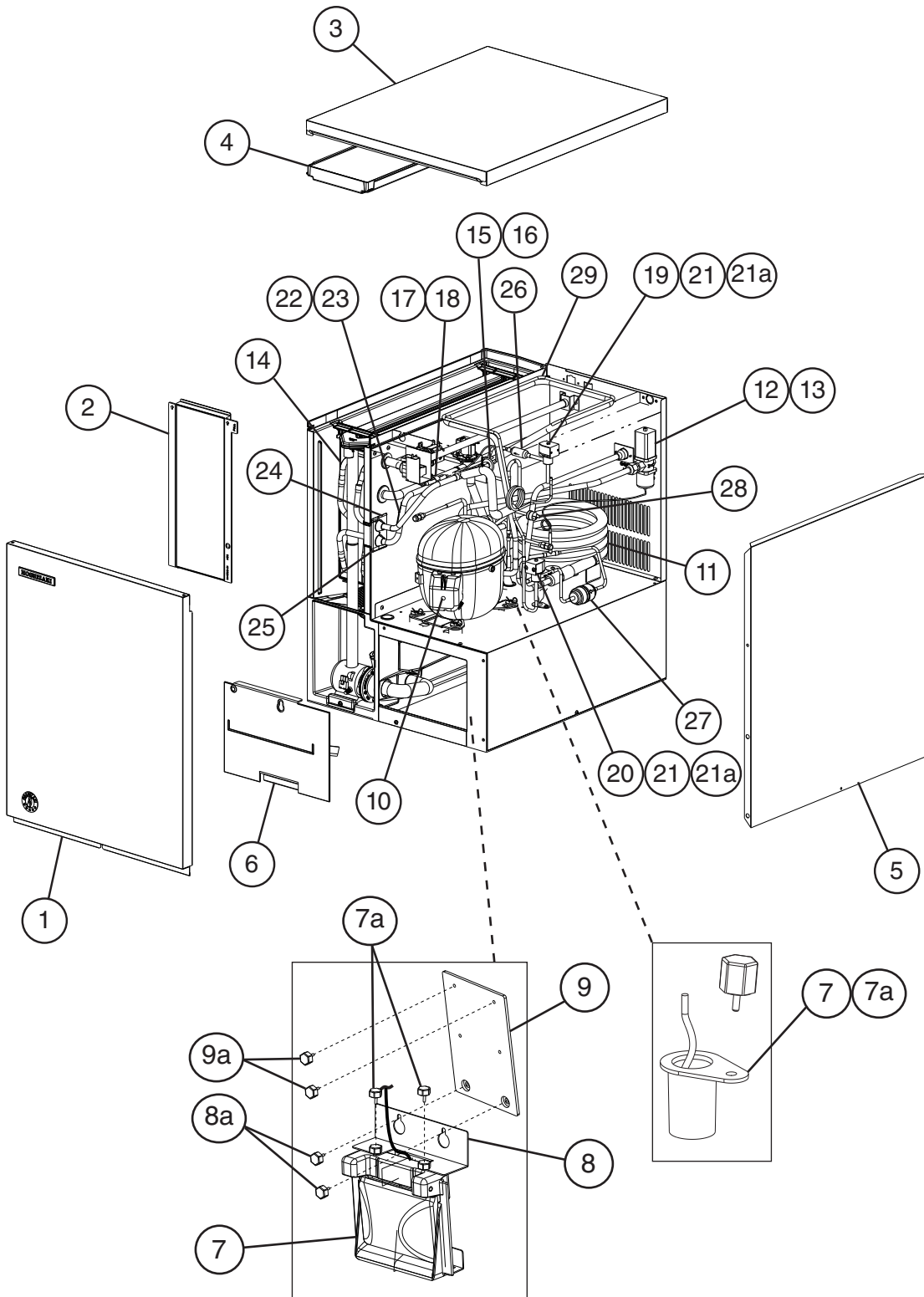

*Used on KM-660MWJ Model

Title: A. Main Assembly and Refrigeration Circuit				Model: KM-350MWJ, KM-420MWJ, KM-520MWJ, KM-660MWJ							
Index No.	Description	Material or Model Number	Part Number	Required Number							
				H-0 to L-0 (J)	L-0 (K)	L-1 to P-2	P-3				
Main Assembly											
1	Front Panel Assembly		1A6183A01	1	1	1	1				
2	Front Insulation		3A9354G01	1	1	1	1				
3	Top Panel Assembly		1A5321G01	1	1	1	-				
			1A6550G01				1				
4	Top Insulation		3A9353G01	1	1	1	1				
5	Right Side Panel		1A5480-01	1	1	1	1				
6	Base Cover		3A9771-01	1	1	1	1				
*7	Ultrasonic Bin Control *See page 5 "Aux Code Break"	KM-350MWJ	4A6148G01	1	1	1	1				
		KM-420MWJ				1					
		KM-520MWJ		1	1	1	1				
		KM-660MWJ		1	-	1	1				
	Mechanical Bin Control *See page 5 "Aux Code Break"	KM-660MWJ	2A8598G01		*1	-					
7a	Screw	KM-350MWJ	7C32-0410	1	1	1	1				
		KM-420MWJ									
		KM-520MWJ									
		KM-660MWJ		1	-	1	1				
	Thumbscrew	KM-660MWJ	415949G08		*2						
8	Mechanical Bin Control Bracket	KM-660MWJ	3A8283-01		*1	-					
8a	Thumbscrews	KM-660MWJ	415949G08		*2	-					
9	Mechanical Bin Control Extention Bracket	KM-660MWJ	4A5046G01		*1	-					
9a	Thumbscrews	KM-660MWJ	438220-01		*2	-					
Refrigeration Circuit											
10	Compressor	KM-350MWJ	4A5090-01	1	1	1	1				
		KM-420MWJ	4A4479-01			1					
		KM-520MWJ	4A4479-01	1	1	1	1				
		KM-660MWJ	4A5158-01	1	1	1	1				
11	Condenser		3A7321-01	1	1	1	1				
12	Water Regulating Valve	KM-350MWJ	4A0911-07	1	1	1	1				
		KM-660MWJ				1					
		KM-520MWJ		4A0911-04			1				
			4A0911-06	1	1	1	1				
13	Male Connector		4A1087-01	1	1	1	1				
14	Evaporator Assembly	All Except KM-420MWJ	1A4119G01	1	1	1	1				
		KM-420MWJ	1A4119G02			1					
15	Thermostatic Expansion Valve		4A4008-02	1	1	1	1				
16	Thermostatic Expansion Valve Cover		4A6853-01	1	1	1	1				
17	Thermostatic Expansion Valve Bulb Holder		3A0107-01	1	1	1	1				
18	Hose Clamp		443461-02	1	1	1	1				
19	Hot Gas Valve Body		4A3978-01	1	1	1	1				
20	Liquid Line Valve Body		4A3276-01	1	1	1	1				
21	Valve Coil		4A3277-01	2	2	2	2				

Title: A. Main Assembly and Refrigeration Circuit Model: KM-350MWJ, KM-420MWJ, KM-520MWJ, KM-660MWJ												
Index No.	Description	Material or Model Number	Part Number	Required Number								
				H-0 to L-0 (J)	L-0 (K)	L-1 to P-2	P-3					
21a	Bolt		4A3277F01	2	2	2	2					
22	Thermistor		429006-03	1	1	1	1					
23	Thermistor Holder		427430-01	1	1	1	1					
24	Rubber Insulation A		3A9637-01	1	1	1	1					
25	Rubber Insulation B		3A9638-01	1	1	1	1					
26	Strainer		441569-04	1	1	1	1					
27	Drier		4A1113-01	1	1	1	1					
28	High-Pressure Switch		463180-05	1	1	1	1					
29	Heat Exchanger		2A9117G01	1	1	1	1					

A. Main Assembly & Refrigeration Circuit
KM-420MRJZ, KM-520MRJ(Z), KM-660MRJ(Z)
 H-0 to P-3

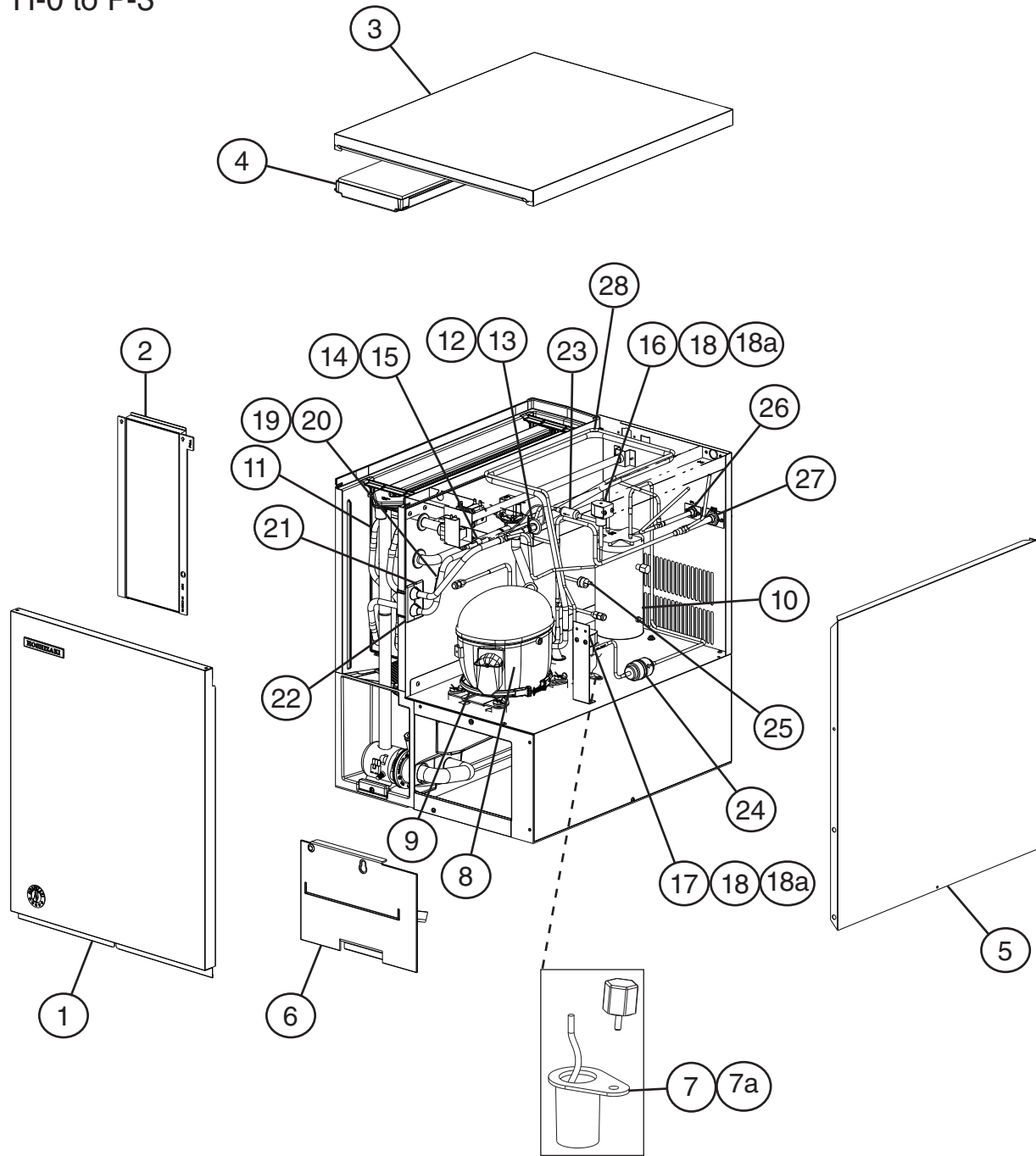

Title: A. Main Assembly & Refrigeration Circuit Model: KM-420MRJZ, KM-520MRJ(Z), KM-660MRJ(Z)										
Index No.	Description	Material or Model Number	Part Number	Required Number						
				H-0 to L-1 (J)	L-0 (K) to P-2	P-3				
Ice Cuber Assembly										
1	Front Panel		1A6183A01	1	1	1				
2	Front Insulation		3A9354G01	1	1	1				
3	Top Panel Assembly		1A5321G01	1	1	-				
			1A6550G01			1				
4	Top Insulation		3A9353G01	1	1	1				
5	Right Side Panel		1A5480-01	1	1	1				
6	Base Cover		3A9771-01	1	1	1				
7	Ultrasonic Bin Control		4A6148G01	1	1	1				
7a	Screw		7C32-0410	1	1	1				
Refrigeration Circuit										
8	Compressor	KM-420MRJZ	4A4479-01		1	1				
		KM-520MRJ(Z)	4A4479-01	1	1	1				
		KM-660MRJ(Z)	4A5158-01	1	1	1				
9	Crankcase Heater		4A5091-01	1	1	1				
10	Receiver Tank		4A6212-01	1	1	1				
11	Evaporator	SP-5425 All Except KM-420MRJZ	1A4119G01	1	1	1				
		KM-420MRJZ	1A4119G02		1	1				
12	Thermostatic Expansion Valve		4A4008-02	1	1	1				
13	Thermostatic Expansion Valve Cover		4A6853-01	1	1	1				
14	Thermostatic Expansion Valve Bulb Holder		3A0107-01	1	1	1				
15	Hose Clamp		443461-02	1	1	1				
16	Hot Gas Valve Body		4A3978-01	1	1	1				
17	Liquid Line Valve Body		4A3276-01	1	1	1				
18	Valve Coil		4A3277-01	2	2	2				
18a	Bolt		4A3277F01	2	2	2				
19	Thermistor		429006-03	1	1	1				
20	Thermistor Holder		427430-01	1	1	1				
21	Rubber Insulation A		3A9637-01	1	1	1				
22	Rubber Insulation B		3A9638-01	1	1	1				
23	Strainer		441569-04	1	1	1				
24	Drier		4A1113-01	1	1	1				
25	High-Pressure Switch		463180-01	1	1	1				
26	Liquid Line Coupling	KM-520MRJ KM-660MRJ	4A3972G01	1	-					
	Liquid Line Service Valve	KM-420MRJZ KM-520MRJZ KM-660MRJZ	4A3491-01		1	1				
27	Discharge Line Coupling	KM-520MRJ KM-660MRJ	434136G01	1	-					
	Discharge Line Service Valve	KM-420MRJZ KM-520MRJZ KM-660MRJZ	4A3491-01		1	1				
28	Heat Exchanger		2A9117G01	1	1	1				

B. Water Circuit

KM-350M_J, KM-420M_J(Z), KM-520M_J(Z), KM-660M_J(Z)

H-0 to P-4

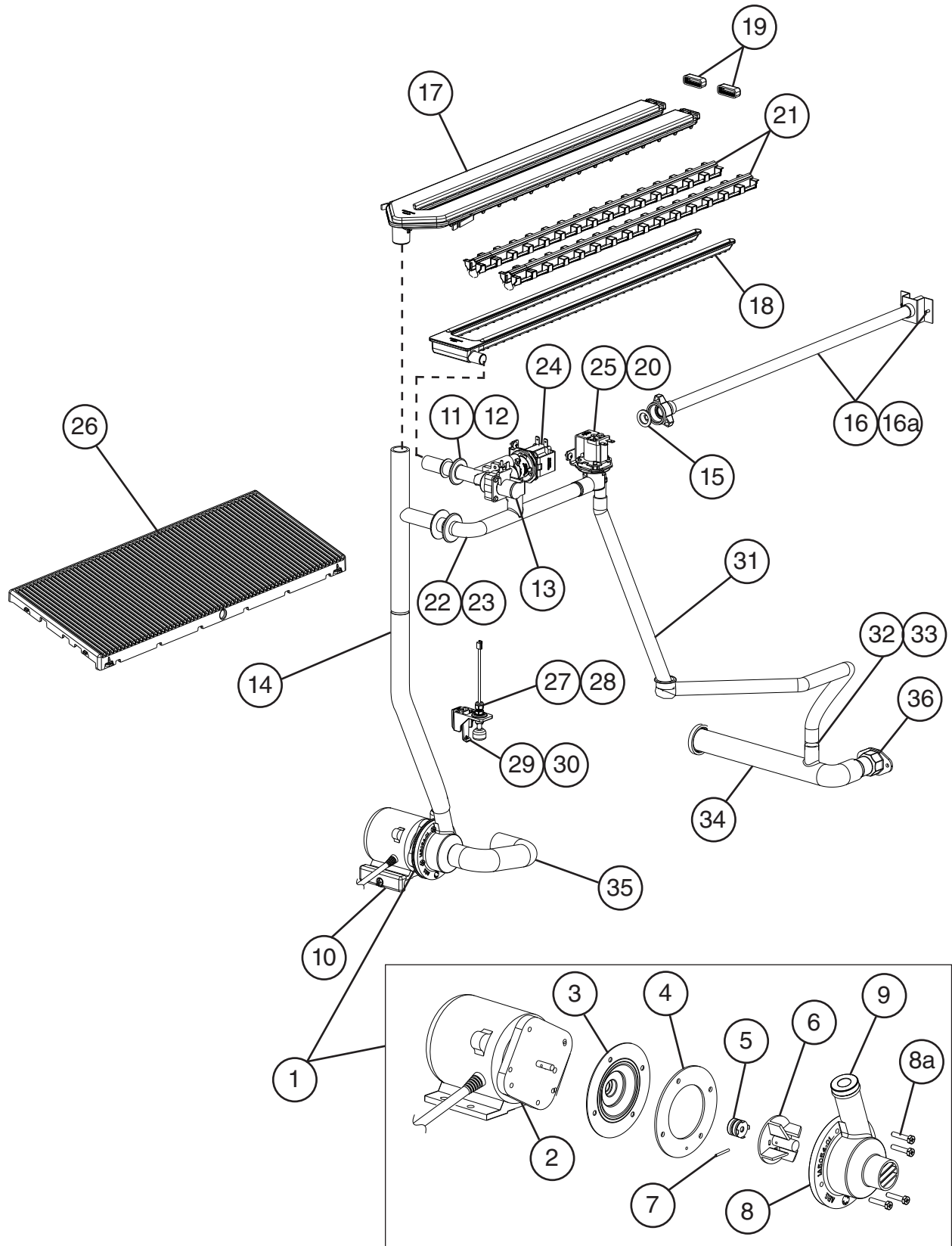

Title: B. Water Circuit Model: KM-350M_J, KM-420M_J(Z), KM-520M_J(Z), KM-660M_J(Z)

Index No.	Description	Material or Model Number	Part Number	Required Number								
				H-0 to K-0	K-1 to N-0	P-0 to P-4						
1	Pump Motor Assembly (includes items 2 through 8)		3A9728A01	1	1	1						
2	Pump Motor		2A2758-01	1	1	1						
3	Pump Flange		3A2988-01	1	1	1						
4	Pump Gasket		4A2974-01	1	1	1						
5	Mechanical Seal		465627-03	1	1	1						
6	Impeller		433522-01	1	1	1						
7	Pin		4A0648-01	1	1	1						
8	Pump Housing Assembly		1A5054-01	1	-							
			3A9778G01		1	1						
8a	Screw	4x20	4A3871-01	4	4	4						
9	Reducing Pipe		4A6178-01	1	1	1						
10	Pump Motor Bracket		1A4670-01	1	1	1						
11	Water Supply Pipe Assembly (includes items 12 through 15)	All Except KM-420MWJ	3B1829A01	1	1	1						
		KM-420MWJ	3A9989A01		1							
12	Water Supply Tee		3A9429-01	1	1	1						
13	Inlet Water Valve	All Except KM-420MWJ	3B1433-03	1	1	1						
		KM-420MWJ	3U0111-03		1							
14	Water Hose		2A8823G01	1	1	1						
15	Rubber Gasket		4A7594-01	1	-							
			413854-03		1	1						
16	Water Supply Pipe		4A5216G04	1	1	1						
16a	Screw		7C32-0408	1	1	1						
17	Spray Tube		1A4571G01	1	1	1						
18	Water Supply Tube		1A4572G01	1	1	1						
19	Cap		4A6069-01	2	-							
			4A6394-01		2	2						
20	Splash Shield		4A6883-01		1	1						
21	Spray Guide		1A4581-01	2	2	2						
22	Solenoid Valve Assembly (includes 23, 24 and 25)		3A9942A01	1	1	1						
23	Bypass Hose		3A9544-01	1	1	1						
24	Cleaning Valve		4A5745-01	1	1	1						
25	Drain Valve		4A5745-03	1	1	1						
26	Cube Guide		1A4568-01	1	1	1						
27	Float Switch Assembly (includes 28, 29 and 30)		4A7080G01	1	1	1						
28	Housing Plug		4A2518-03	1	1	1						
29	Bracket		4A7080F01	1	1	1						
30	Stem		4A7080F02	1	1	1						
31	Silicone Hose	L= 140mm	7730-1114	1	1	1						
32	Drain Hose Assembly (includes 33 and 34)		3A9796A01	1	1	1						
33	Joint Pipe		4A6286-01	1	1	1						
34	Drain Hose		1A4579-01	1	1	1						
35	Suction Hose		433466-01	1	1	1						
36	Drain Fitting		4A5528-02	1	1	1						

C. Control Box Assembly

KM-350M_J, KM-420M_J(Z), KM-520M_J(Z), KM-660M_J(Z)

H-0 to P-4

Control Board 2A8242-02

Control Board with
Ultrasonic Sensor
Control Board

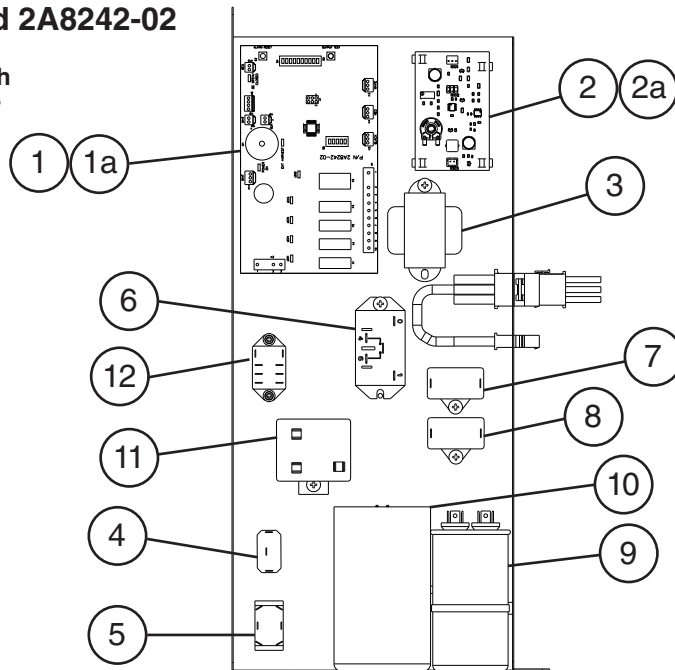

Control Board 2A9678-02

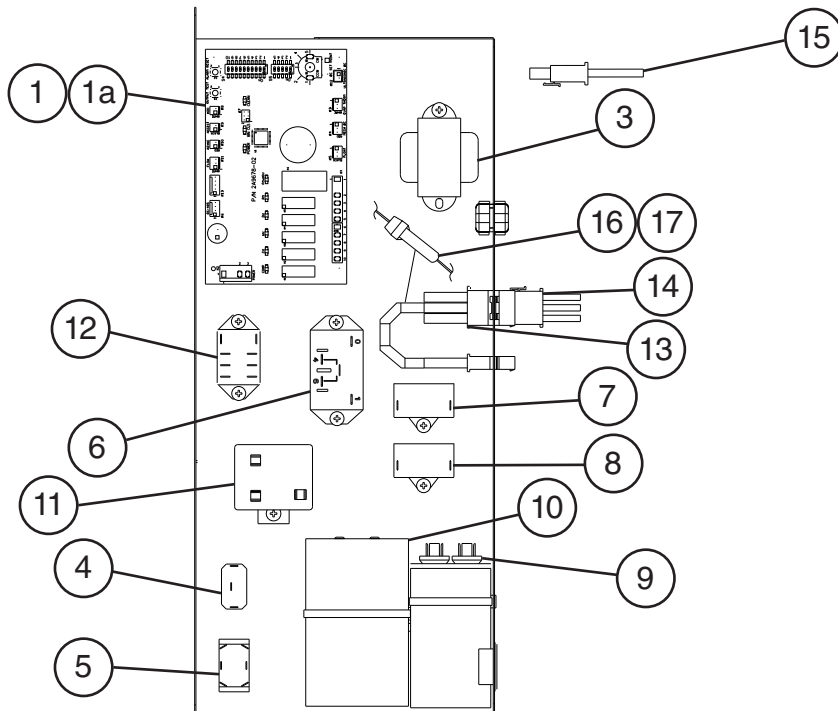

Title: C. Control Box Assembly Model: KM-350M_J, KM-420M_J(Z), KM-520M_J(Z), KM-660M_J(Z)												
Index No.	Description	Material or Model Number	Part Number	Required Number								
				H-0 to L-0 (J)	L-0 (K)	L-0 (L) to L-1 (J)	L-1 (K)	L-1 (L) to P-2	P-3	P-4		
1	Control Board *See page 5 Aux Code Break	KM-350MAJ	SP-5648	1	1	1	1*	-				
		KM-350MWJ		1	1	1	-					
		KM-350MAJ	2A9678-01				*1	1	1	-		
		KM-350MWJ	2A9678-02								1	
		KM-420M_J(Z)	2A9678-01					1				
		KM-520MAJ	SP-5648	1	*1	-						
		KM-520MWJ		2A9678-01		*1	1	1	1	-		
				2A9678-02						1	1	
		KM-520MRJ	SP-5648	1	-							
		KM-520MRJZ		2A9678-01		1	1	1	1	-		
				2A9678-02						1	1	
		KM-660MAJ	SP-5648	1	*1	-						
		KM-660MWJ		2A9678-01			1	1	1	-		
				2A9678-02						1	1	
KM-660MRJ	SP-5648	1	-									
KM-660MRJZ		2A9678-01		1	1	1	1	-				
		2A9678-02						1	1			
1a	Control Board Support		4A0336-03	4	4	4	4	4	4	4		
2	Ultrasonic Bin Control Board *See page 4 "Aux Code Break"	KM-350MAJ	4A6838-01	1	1	1	*1	-				
		KM-520MAJ		1	*1	-						
		KM-660MAJ		1	*1	-						
		KM-350MWJ		1	-							
		KM-520MWJ		1	-							
		KM-660MWJ		1	*1	-						
		KM-520MRJ		1	-							
		KM-660MRJ		1	-							
2a	Control Board Support		4A0336-03	4	4	4	4	-				
3	Control Transformer		3A0172-01	1	1	1	1	1	1	1		
4	Control Switch		4A0985-01	1	1	1	1	1	1	1		
5	Mode Switch		4A6232-01	1	1	1	1	1	1	1		
6	Compressor Relay		4A3140-01	1	1	1	1	1	1	1		
7	Pump Motor Capacitor	5.5MFD, 250VAC	4A6435-03	1	1	1	1	1	1	1		
8	Fan Motor Capacitor	5.0MFD, 250VAC	4A6435-02	1	1	1	1	1	1	1		
9	Run Capacitor	KM-350M_J KM-420M_J KM-520M_J 35MFD, 440VAC	3A2005-12	1	1	1	1	1	1	1		
		KM-660M_J 40MFD, 440VAC	3A2005-07	1	1	1	1	1	1	1		

Title: C. Control Box Assembly Model: KM-350M_J, KM-420M_J(Z), KM-520M_J(Z), KM-660M_J(Z)

Index No.	Description	Material or Model Number	Part Number	Required Number								
				H-0 to L-0 (J)	L-0 (K)	L-0 (L) to L-1 (J)	L-1 (K)	L-1 (L) to P-2	P-3	P-4		
10	Start Capacitor	KM-350M_J KM-520M_J(Z) 243-292MFP 165VAC	3A0076-20	1	1	1	1	1	1	1		
		KM-420M_J(Z) 243-292MFP 165VAC					1					
		KM-660M_J(Z) 243-292MFP 250VAC	3A0076-21	1	1	1	1	1	1	1		
11	Start Relay	KM-350M_J	4A1107-18	1	1	1	1	1	1	1		
		KM-420M_J(Z)	4A1107-11					1				
		KM-520M_J(Z)		1	1	1	1	1	1	1		
		KM-660M_J(Z)	4A1107-20	1	1	1	1	1	1	1		
12	Relay X10=Crankcase Heater Relay	KM-420MRJZ	406132-07					1				
		KM-520MRJ(Z)		1	1	1	1	1	1	1		
		KM-660MRJ(Z)										
13	Wire Harness A	KM-350M_J	1A4291-01	1	1	1	-					
	Wire Harness A (includes items 16 and 17)	KM-350M_J	1A4291-02				1	1	1	1		
	Wire Harness A	KM-520M_J(Z)	1A4291-01	1	-							
	Wire Harness A (includes items 16 and 17)	KM-660M_J(Z)	1A4291-02		1	1	1	1	1	1		
		KM-420M_J(Z)						1				
14	Wire Harness B	ALL Models	1A4292-01	1	1	1	1	1	1	1		
15	Wire Harness C	KM-420MRJZ	1A5041-01					1				
		KM-520MRJZ		1	1	1	1	1	1	1		
		KM-660MRJZ										
16	Fuse	AGC-10A, 250VAC	4A0893-07	1	1	1	1	1	1	1		
17	In-Line Fuse Holder		4A6950-01	1	1	1	1	1	1	1		

D. Accessories & Labels

KM-350M_J, KM-420M_J(Z), KM-520M_J(Z), KM-660M_J(Z)

H-0 to P-4

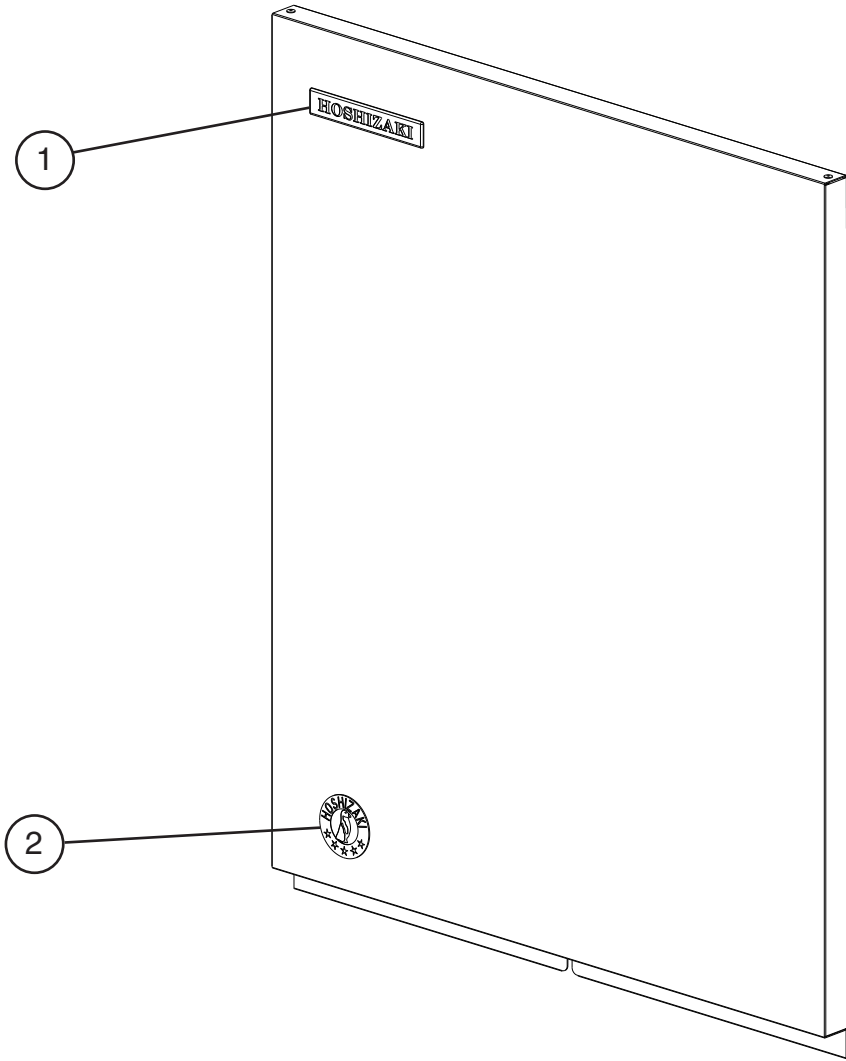

Index No.	Description	Material or Model Number	Part Number	Required Number									
				H-0 to P-4									
1	Hoshizaki Emblem		4A0560-01	1									
2	Penguin Label		475552L02	1									
3	Universal Brace		4A0363-01	2									
3a	Hex Head Bolt	5x12, SS	7B02-0512	2									