



Reliability is a
beautiful thing™

HOSHIZAKI® **STACKABLE CRESCENT CUBER**

MODEL
KM-2400SRH3

INSTRUCTION MANUAL



ISSUED: NOV. 14, 2000

REVISED: DEC. 11, 2003

IMPORTANT

Only qualified service technicians should attempt to install, service or maintain this icemaker. No installation, service or maintenance should be undertaken until the technician has thoroughly read this Instruction Manual. Likewise, the owner/manager should not proceed to operate the icemaker until the installer has instructed them on its proper operation.

HOSHIZAKI provides this manual primarily to assist qualified service technicians in the installation, maintenance and service of the icemaker.

Should the reader have any questions or concerns which have not been satisfactorily addressed, please call or write to the HOSHIZAKI Technical Support Department for assistance.

HOSHIZAKI AMERICA, INC.
618 Highway 74 South
Peachtree City, GA 30269

Attn: HOSHIZAKI Technical Support Department

Phone: 1-800-233-1940 Technical Service
(770) 487-2331
Fax: (770) 487-3360

NOTE: To expedite assistance, all correspondence/communication **MUST** include the following information:

- Model Number
- Serial Number
- Complete and detailed explanation of the problem

- Please review this manual. It should be read carefully before the icemaker is installed and operated. Only qualified service technicians should install, service and maintain the icemaker. This manual should be made available to the technician prior to installation, maintenance or service.
- Keep this manual with the icemaker for later reference.



CONTENTS	PAGE
I. SPECIFICATIONS	4
1. NAMEPLATE RATING	4
2. DIMENSIONS/CONNECTIONS	5
II. INSTALLATION AND OPERATING INSTRUCTIONS	6
1. CHECKS BEFORE INSTALLATION	6
2. HOW TO REMOVE PANELS	6
3. LOCATION	7
4. SET UP	7
5. INSTALLATION OF THE SECOND UNIT	10
6. ELECTRICAL CONNECTION	12
7. INSTALLATION OF REMOTE CONDENSER UNIT	13
[a] CHECKS BEFORE INSTALLATION	13
[b] LOCATION	13
[c] SET UP	14
[d] ELECTRICAL CONNECTION	16
8. WATER SUPPLY AND DRAIN CONNECTIONS	17
9. FINAL CHECK LIST	19
10. START UP	20
11. PREPARING THE ICEMAKER FOR LONG STORAGE	22
III. MAINTENANCE AND CLEANING INSTRUCTIONS	23
1. CLEANING INSTRUCTIONS	23
[a] CLEANING PROCEDURE	24
[b] SANITIZING PROCEDURE	25
2. MAINTENANCE INSTRUCTIONS	26

I. SPECIFICATIONS

1. NAMEPLATE RATING

HOSHIZAKI ICE MAKER				
MODEL NUMBER	KM-2400SRH3			
SERIAL NUMBER				
AC SUPPLY VOLTAGE	208-230/60/3			
COMPRESSOR	200-230V	15.0RLA	125LRA	
PUMP	120V	1.2FLA	60W	
FAN	REMOTE	208-230V	5A	MAX
OTHER	115V	0.3A		
MAXIMUM FUSE SIZE	30AMPS			
MAX. HACR BREAKER (USA ONLY)	30AMPS			
MAX. CIRC. BREAKER (CANADA ONLY)	30AMPS			
MINIMUM CIRCUIT AMPACITY	30AMPS			
DESIGN PRESSURE	HI-467PSI	LO-230PSI		
REFRIGERANT 404A				
MOTOR-COMPRESSOR THERMALLY PROTECTED				
NOT INTENDED FOR OUTDOOR USE				

HOSHIZAKI AMERICA, INC.
Peachtree City, GA

 LISTED ICE MAKER WITHOUT STORAGE MEANS 946Z		 COMPONENT
--	---	---

See the Nameplate for electrical and refrigeration specifications. This Nameplate is located on the upper right hand side of rear panel.

Since this Nameplate is located on the rear panel of the icemaker, it cannot be read when the back of the icemaker is against a wall or against another piece of kitchen equipment. Therefore, the necessary electrical and refrigeration information is also on the rating label, which can be easily seen by removing only the front panel of the icemaker.

We reserve the right to make changes in specifications and design without prior notice.

2. DIMENSIONS/CONNECTIONS

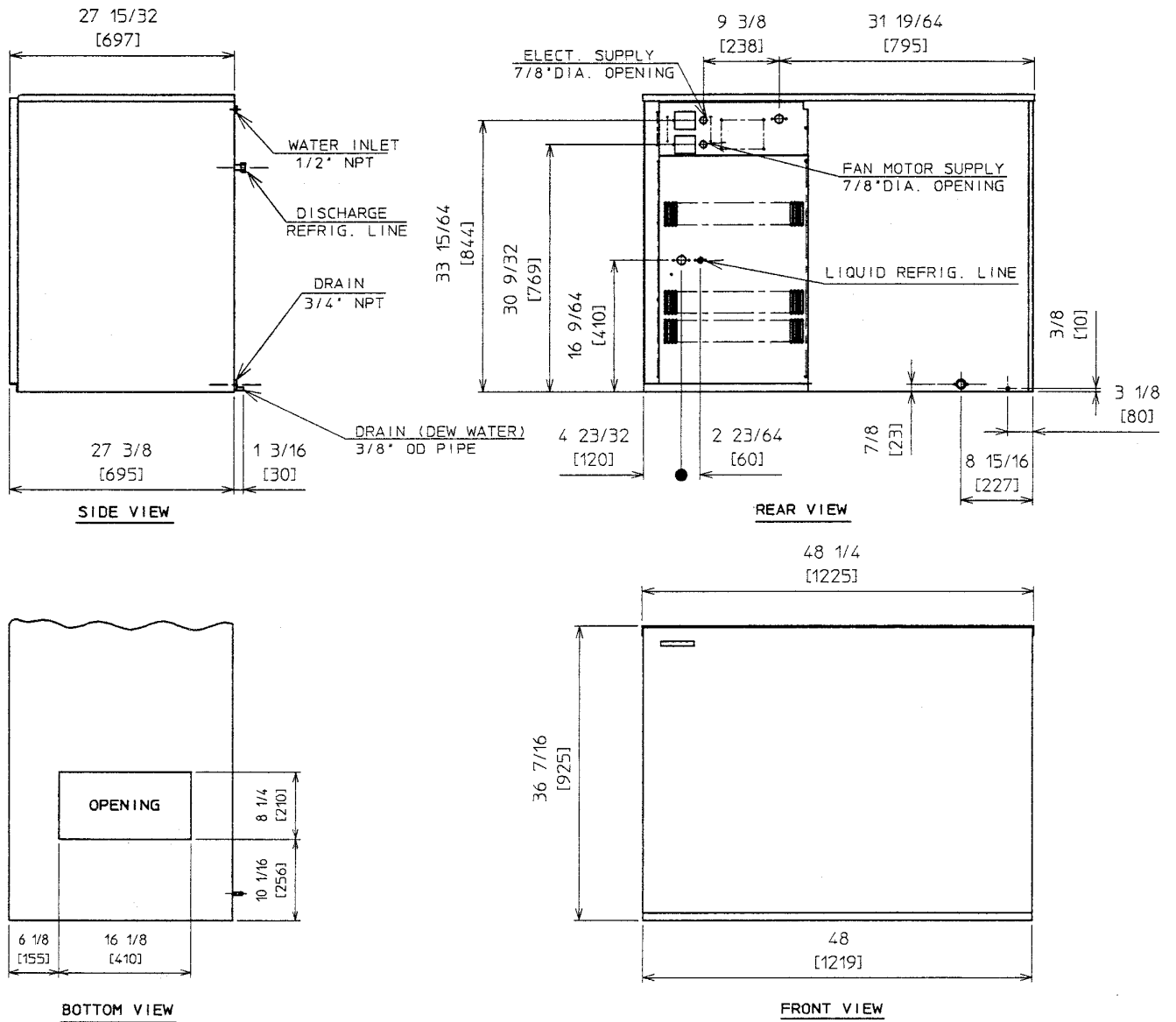

Note: When used with a storage bin not recommended by Hoshizaki, the icemaker needs the space at the bottom opening as in the illustration.

II. INSTALLATION AND OPERATING INSTRUCTIONS

1. CHECKS BEFORE INSTALLATION

IMPORTANT

1. Remove shipping carton, tape(s) and packing. If packing material is left in the icemaker, it will not work properly.
2. Ensure all components, fasteners and thumbscrews are securely in place.

- 1) Remove the panels to prevent damage when installing the icemaker. (See "2. HOW TO REMOVE PANELS.")
- 2) Remove the package containing the accessories from the compressor compartment.
- 3) Remove the protective plastic film from the panels. If the icemaker has been exposed to the sun or to heat, remove the film after the icemaker cools.
- 4) Check that the refrigerant lines do not rub or touch lines or other surfaces.
- 5) Check that the Compressor is snug on all mounting pads.
- 6) See the Nameplate on the Rear Panel, and check that your voltage supplied corresponds with the voltage specified on the Nameplate.
- 7) This icemaker needs a storage bin. The recommended storage bin is HOSHIZAKI ICE STORAGE BIN, Model B-800 series.
- 8) On remote air-cooled models, a remote condenser unit is needed. The recommended remote condenser unit is HOSHIZAKI CONDENSER UNIT, Model URC-24F.

2. HOW TO REMOVE PANELS - See Fig. 1

- a) Front Panel Remove the two screws.
Lift up and pull toward you.
- b) Top Panel Remove the two screws,
and then lift off.
- c) Side Panel (R) Remove the screw.
Pull slightly toward you,
and take off.
- d) Insulation Panel .. Remove the Thumbscrew.
Lift up slightly, and pull toward
you.

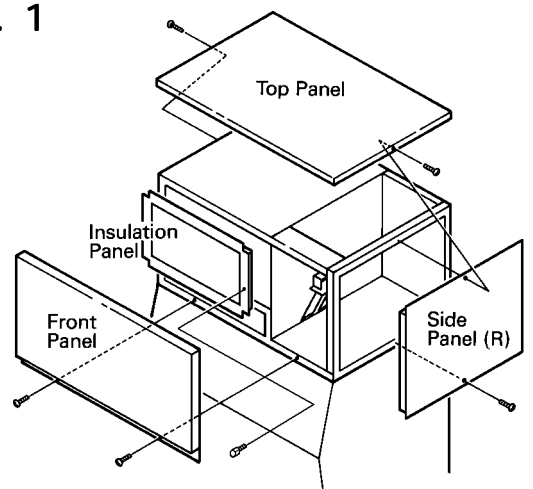

Fig. 1

3. LOCATION

CAUTION

This icemaker is not intended for outdoor use. Normal operating ambient temperature should be within +45°F to +100°F; Normal operating water temperature should be within +45°F to +90°F. Operation of the icemaker, for extended periods, outside of these normal temperature ranges may affect production capacity.

For best operating results:

- Icemaker should not be located next to ovens, grills or other high heat producing equipment.
- Location should provide a firm and level foundation for the equipment.
- Allow 6" clearance at rear, sides and top for proper air circulation and ease of maintenance and/or service should they be required.

4. SET UP

- 1) Unpack the Storage Bin, and attach the four adjustable legs provided (bin accessory) to the bottom of the Storage Bin.
- 2) Position the Storage Bin in the selected permanent position.
- 3) Stack the icemaker on top of the Storage Bin.
- 4) Secure the icemaker to the Storage Bin by using the two Universal Braces and two of the bolts provided. See Fig. 2.

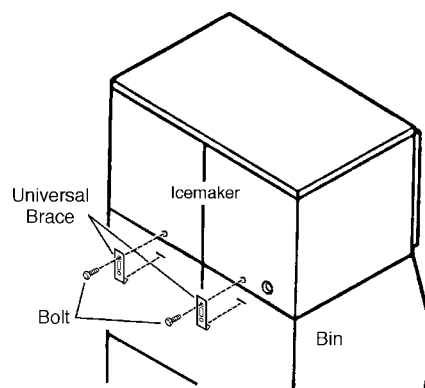

Fig. 2

IMPORTANT

Before operating the icemaker, the Bin Control Thermostat must be installed correctly.

- 5) Install the Bin Control Thermostat as follows. See Figures 3a, b and c.
 - (a) Remove the Tie securing the Bulb Holder. Remove the Thermostat Bracket (A) from the Shipping Hook by lifting up the Bracket (A) and shifting it to the right.
 - (b) Lower the Thermostat Bracket through the hole located at the bottom of the icemaker.
 - (c) Slide the Thermostat Bracket (A) toward you with the bottom surface contacting the Thermostat Bracket (B).
 - (d) Hook the Thermostat Bracket (A).
 - (e) Insert the Plug into the Receptacle on the Bracket until it locks in place.

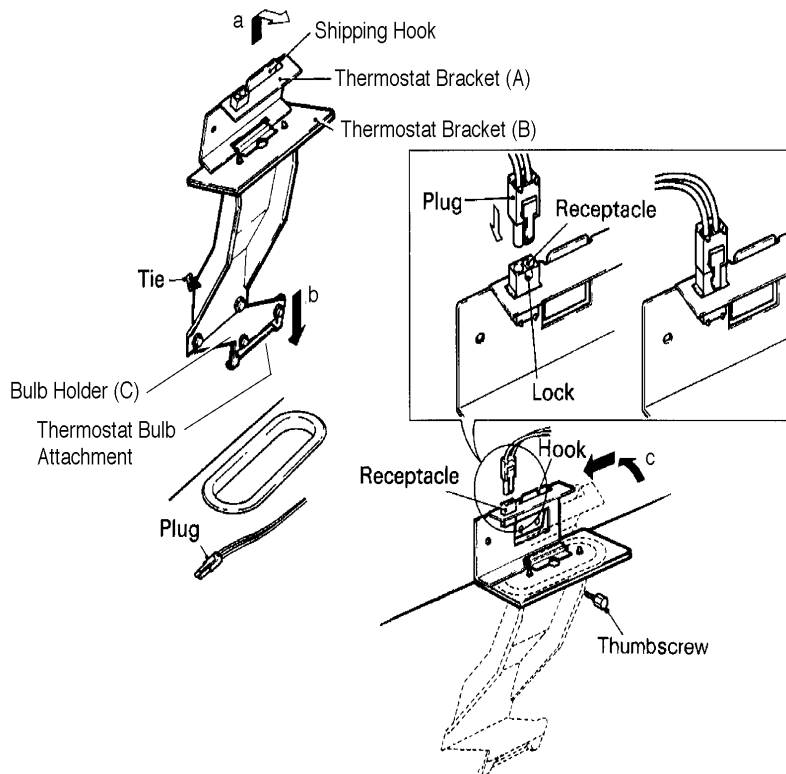

Fig. 3a

- (f) Secure the Thermostat Bracket in place with the thumbscrew.
- (g) Remove the Bin Control Bracket Extension from the accessory bag.
- (h) Remove the Baffle from the Bin.
- (i) Remove the two screws holding the Bulb Holder (C) to the Thermostat Bracket (B).

If a Hoshizaki Bin is being used:

- (j) Remove the two screws holding the Bulb Holder (C) and the Thermostat Bulb Attachment together. Put aside the Bulb Holder (C); it is not needed with the Hoshizaki Bin.
- (k) Use two of the screws to attach the Bin Control Bracket Extension to the Thermostat Bracket (B).
- (l) Use the two 4 x 10 stainless steel screws in the accessory bag to attach the Thermostat Bulb Attachment to the Bin Control Bracket Extension. See Fig. 3b.
- (m) Reinstall the Baffle in the Bin.

If a non-Hoshizaki Bin is being used:

- (j) Use the two screws from (i) to attach the Bin Control Bracket Extension to the Thermostat Bracket (B).
- (k) Use the two 4 x 10 stainless steel screws in the accessory bag to attach the Bulb Holder (C) (with attached Thermostat Bulb) to the Bin Control Bracket Extension. See Fig. 3c.
- (l) Reinstall the Baffle in the Bin.

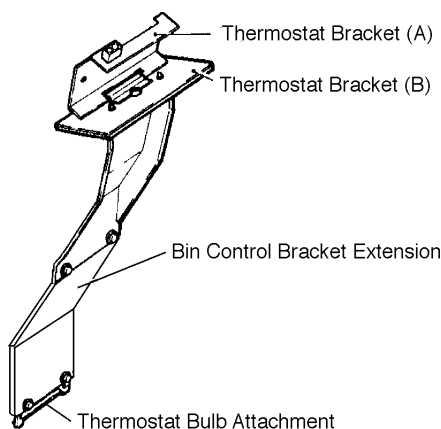

Fig. 3b

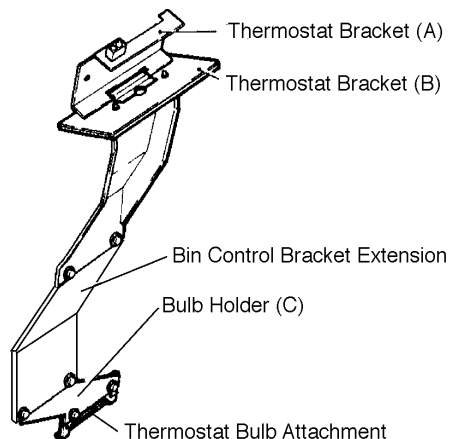

Fig. 3c

- 6) Level the icemaker/Storage Bin in both the left-to-right and front-to-rear directions. Adjust the Ice Bin Legs to make the icemaker level.
- 7) Place the panels in position.

5. INSTALLATION OF THE SECOND UNIT - See Figures 4 and 5

- 1) See "4. SET UP" for the lower unit installation.
- 2) Remove the Top Panel and the Top Insulation of the lower unit. The Top Panel and the Top Insulation of the lower unit are not required when installing the second icemaker.
- 3) Unpack the second icemaker (upper unit), and remove all shipping cartons, tape(s) and packing.

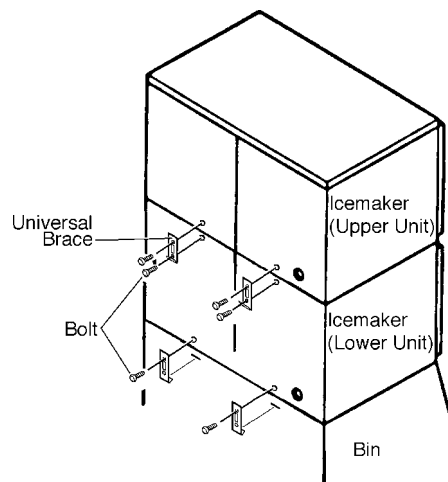

Fig. 4

- 4) Remove the panels of the second icemaker.
- 5) Stack the upper unit on the top of the lower unit.
- 6) Secure the upper unit to the lower unit by using the two Universal Braces and the four bolts provided.
- 7) Remove the Thermostat Bulb Attachment of the upper unit from the Thermostat Bracket.
- 8) Route the Bin Control Thermostat Capillary Tubing of the upper unit through the bottom hole of the upper unit and the Thermostat Bracket of the lower unit. Secure the Thermostat Bulb of the upper unit to the Thermostat Bulb Attachment of the lower unit with the Thermostat Bulb Attachment and the screws of the upper unit.

9) Insert the plug of the upper unit into the receptacle of the upper unit on the Bracket until it locks in place.

10) Place the panels in position.

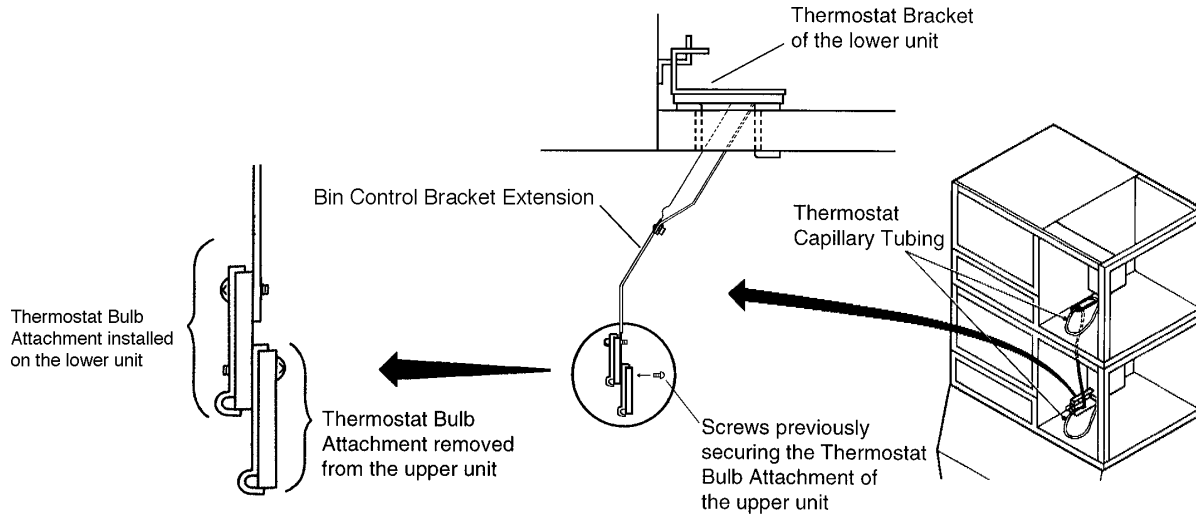

Fig. 5a (with Hoshizaki Bin)

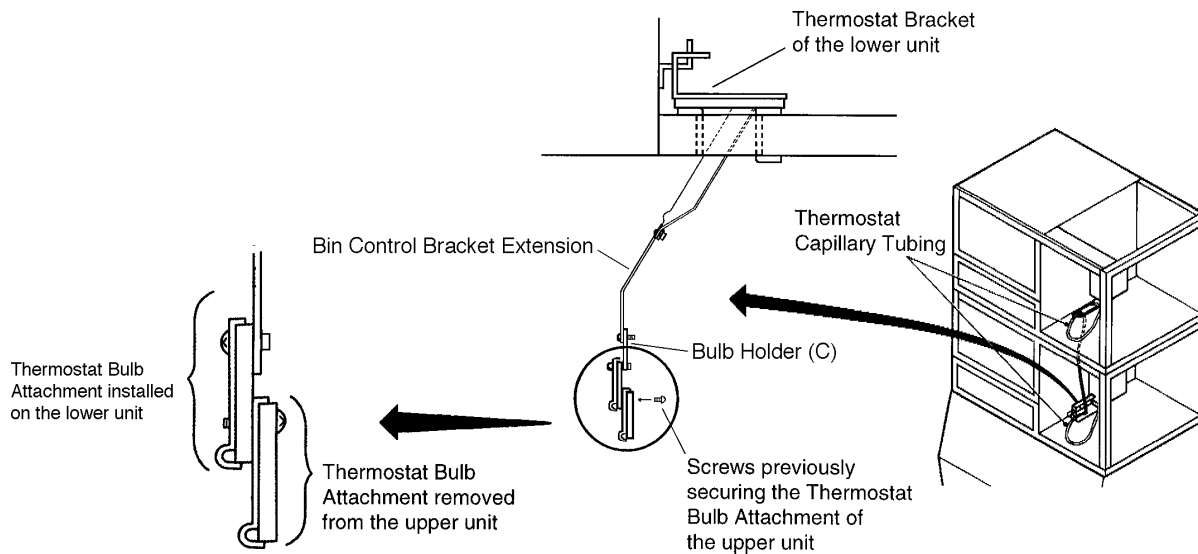

Fig. 5b (with Non-Hoshizaki Bin)

6. ELECTRICAL CONNECTION

WARNING

1. Electrical connection must be made in accordance with the instructions on a "WARNING" tag, provided with the pig tail leads in the Junction Box.
2. This icemaker requires a ground that meets the national and local electrical code requirements. To prevent possible electrical shock to individuals or extensive damage to the equipment, install a proper ground wire to the icemaker.

- The Voltage Tap Switch in the unit should be positioned to match incoming voltage at start-up. See Fig. 6.
- This icemaker must have a separate power supply or receptacle of proper capacity. See the Nameplate.
- The opening for the power supply connection is 7/8" DIA to fit a 1/2" trade size conduit.
- When excessive voltage is supplied to the Controller Board, the icemaker stops running in 3 seconds. See "10. START UP."
- Usually an electrical permit and services of a licensed electrician are required.

WARNING

ELECTRICAL CONNECTION

This icemaker must be connected to three phase power source. Miswiring results in severe damage to the icemaker. (See Fig. below.)

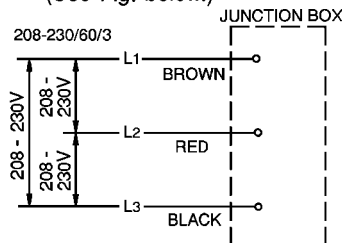

Voltage tap switch in the unit should be positioned to match incoming voltage at start-up.

Fig. 6

7. INSTALLATION OF REMOTE CONDENSER UNIT

[a] CHECKS BEFORE INSTALLATION

- 1) Unpack and remove shipping carton, tape(s) and packing.
- 2) Check that the refrigerant lines do not rub or touch lines or other surfaces, and that the fan blade turns freely.

[b] LOCATION

The condenser unit must be positioned in a permanent site under the following guidelines.

- A firm and flat site.
- A dry and well ventilated area with 24" clearance on both front and rear for ease of maintenance and service should they be required.
- Normal condenser ambient temperature: -20°F to $+122^{\circ}\text{F}$. Temperatures not within this operating range may affect the production capacity of the icemaker.
- When the condenser unit is installed on a roof, a base 20" in height is recommended to prevent heat reflection from decreasing the performance of the condenser.
- The maximum line length for the standard refrigerant charge is 66 feet. Should an installation require a longer line length, please call 1-800-233-1940 for recommendations concerning the correct additional refrigerant charge to be added.

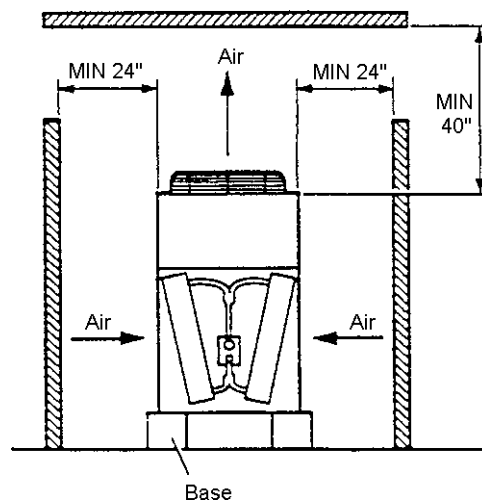

Fig. 7

Note: If the recommended guidelines of the installation are exceeded, the icemaker performance may be reduced.

[c] SET UP

- 1) Secure the condenser unit with four M8 anchor bolts and four M8 Nuts as shown in the illustration. See Fig. 8.
- 2) Install enough length of two copper tubings provided with Aeroquip couplings between the icemaker and the condenser unit. The two copper tubings should be insulated separately. See Fig. 9.
 - A connector kit "OS-QUICK" is available for field-fabricated lines from Hoshizaki America.
 - R-404A precharged tubing kits, available as optional equipment from Hoshizaki America, are recommended.
- 3) Line sets fabricated in the field should be evacuated through the charging ports on the Aeroquip couplings and charged with R-404A refrigerant vapor to a pressure of 15 - 30 PSIG.

Note: Factory fabricated tubing kits are precharged and do not need to be evacuated.

- 4) Remove the plastic caps protecting the couplings. Attach the two refrigerant lines to the male couplings on the icemaker and the remote condenser unit. Each refrigerant line must be connected as follows:

Icemaker discharge refrigerant line - 5/8" OD tubing to "DIS" of condenser unit
Icemaker liquid refrigerant line - 3/8" OD tubing to "LIQ" of condenser unit

Note: Care should be taken that the unit, line set and Condenser contain the same type refrigerant prior to making connections. Mixing of refrigerants will result in improper operation and possible damage to the refrigeration system. Make the connections at the remote condenser first and then at the icemaker.

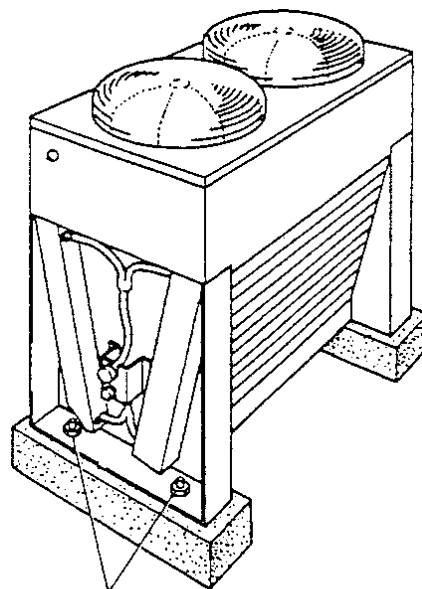

M8 Anchor Bolts
with M8 Nuts

Fig. 8

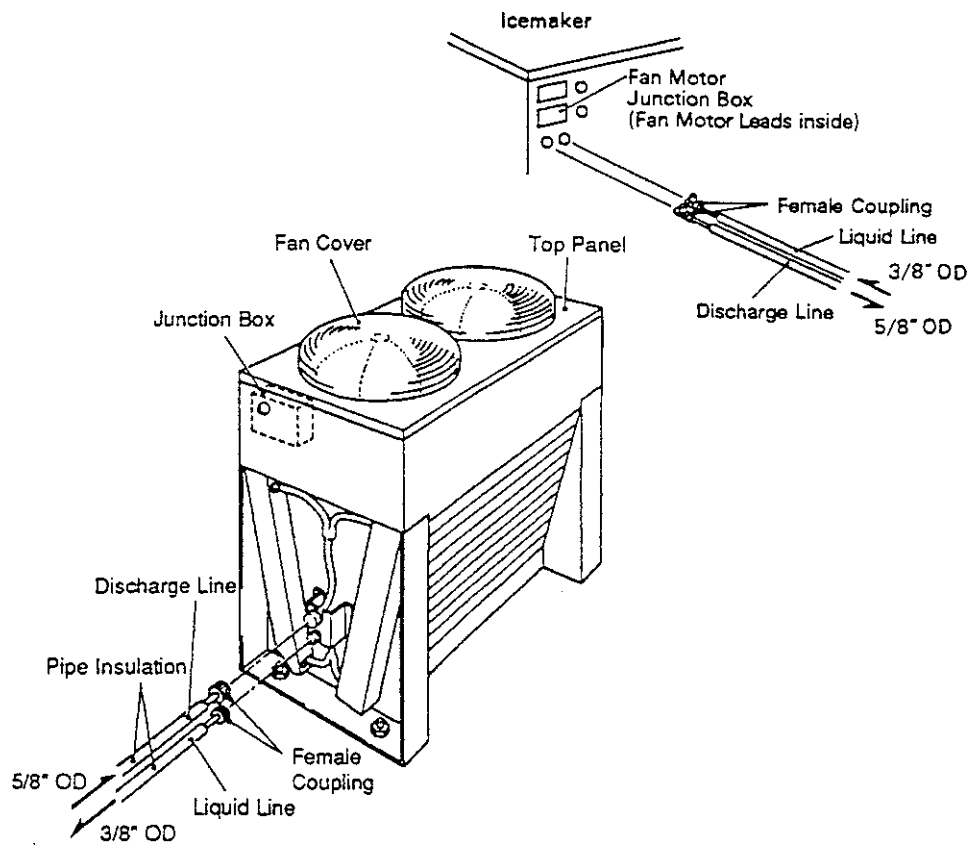

Fig. 9

[d] ELECTRICAL CONNECTION

WARNING

This remote condenser unit requires a ground that meets the national and local electrical code requirements. To prevent possible electrical shock to individuals or extensive damage to equipment, install a proper ground wire to this condenser unit.

- This condenser unit must be connected to the Fan Motor Junction Box on the icemaker.
- The opening for the power supply connection is 7/8" DIA to fit a 1/2" trade size conduit.
- Usually an electrical permit and services of a licensed electrician are required.

- 1) Remove the Top Panel.
- 2) Remove the Junction Box Cover.
- 3) Connect the Fan Motor leads in the Junction Box of the remote condenser unit to the Fan Motor leads in the Junction Box of the HOSHIZAKI remote air-cooled icemaker.
- 4) Install a ground wire from the icemaker to the remote condenser unit.
- 5) Place the Junction Box Cover and the Panel in position.

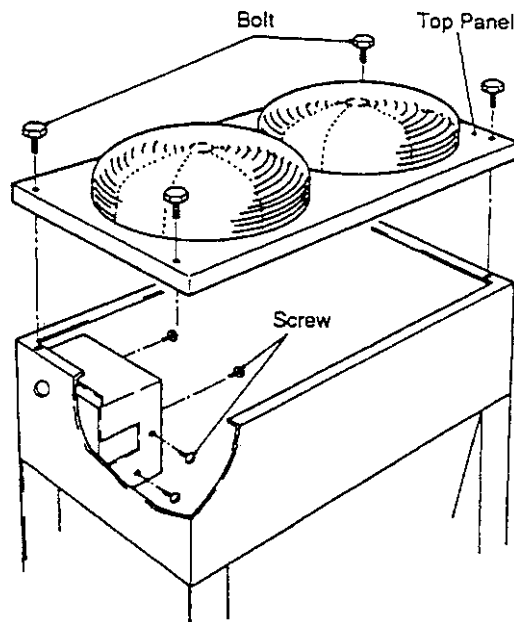

Fig. 10

8. WATER SUPPLY AND DRAIN CONNECTIONS - See Fig. 11

WARNING

To prevent damage to the pump assembly, do not operate the icemaker when the water supply is OFF, or if the pressure is below 10 PSIG. Do not run the icemaker until the proper water pressure is reached.

- Water supply inlet is 1/2" female pipe thread (FPT).
- A water supply line shut-off valve and drain valve should be installed. A minimum of 5/8" OD copper tubing is recommended for the water supply lines.
- Water supply pressure should be a minimum of 10 PSIG and a maximum of 113 PSIG. If the pressure exceeds 113 PSIG, the use of a pressure reducing valve is required.
- Drain outlet for icemaker dump is 3/4" FPT. The drain for condensation is a 3/8" ID pipe. The icemaker drain must be made separately from the bin drain.
- The drains must have 1/4" fall per foot on horizontal runs to get a good flow.
- The drains should not be piped directly to the sewer system. An air gap of a minimum of 2 vertical inches should be between the end of the drain pipe from the icemaker or the ice bin and the floor drain.
- This icemaker should be installed in accordance with applicable national, state and local regulations.
- A plumbing permit and services of a licensed plumber may be required in some areas.
- The icemaker should be installed in accordance with applicable national, state and local regulations.

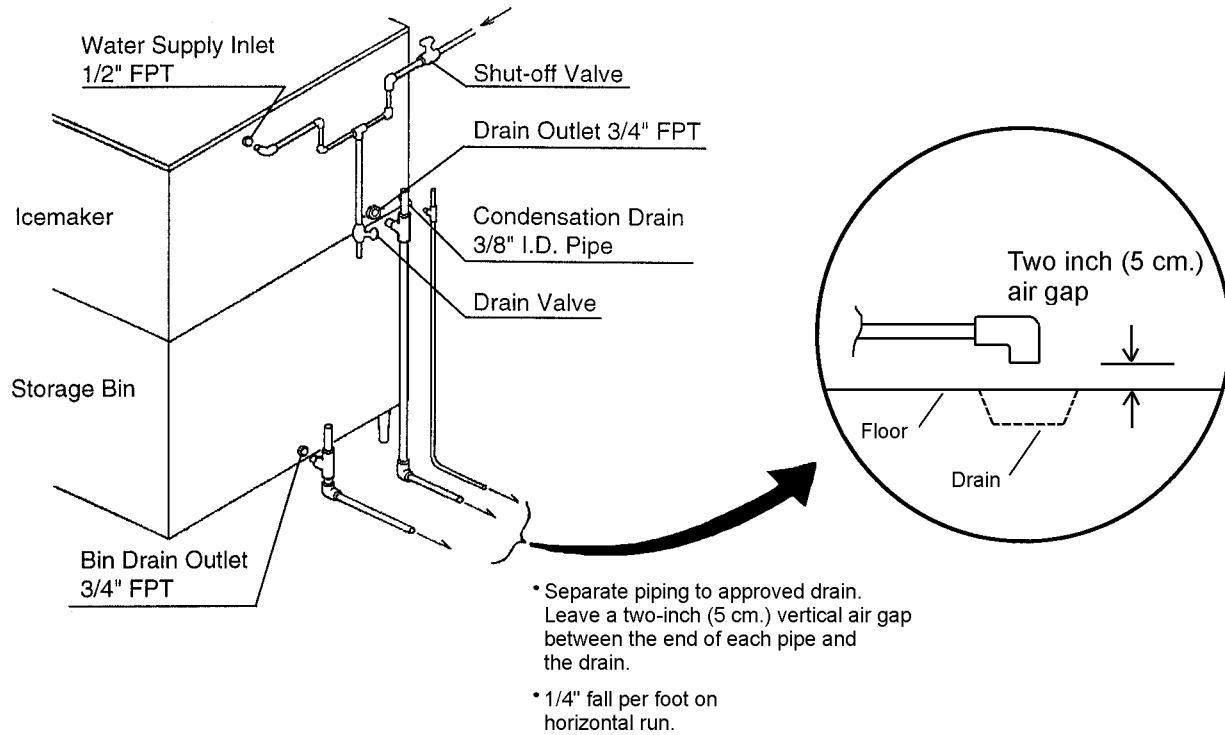

Fig. 11

9. FINAL CHECK LIST

- 1) Is the icemaker level?
- 2) Is the icemaker in a site where the ambient temperature is within +45°F to +100°F all year around?
- 3) Is there at least a 6" clearance around the icemaker for maintenance or service?
- 4) Have all shipping tape(s), packing and cartons been removed from the icemaker? Are the cube guides in their correct position? Are the separators properly attached to their holding clips?
- 5) Are all components, fasteners and thumbscrews securely in place?
- 6) Have all electrical and piping connections been made?
- 7) Has the power supply voltage been checked or tested against the nameplate rating? Has the Voltage Tap Switch been positioned to match incoming voltage? And has a proper ground been installed in the icemaker?
- 8) Are the Water Supply Line Shut-off Valve and Drain Valve installed? Has the water supply pressure been checked to ensure a minimum of 10 PSIG and a maximum of 113 PSIG?

Note: The icemaker may stop running when the water supply is OFF, or if the pressure is below 10 PSIG. When the proper water pressure is reached, the icemaker automatically starts running again.
- 9) Have the compressor hold-down bolts and refrigerant lines been checked against vibration and possible failure?
- 10) Has the Bin Control Switch been checked for correct operation? When the icemaker is running, hold an ice cube in contact with the Bulb. The icemaker should stop within 6 to 10 seconds.
- 11) Has the end user been given the instruction manual, and instructed on how to operate the icemaker and the importance of the recommended periodic maintenance?
- 12) Has the end user been given the name and telephone number of an authorized service agent?
- 13) Has the warranty tag been filled out and forwarded to the factory for warranty registration?

10. START UP

CAUTION

1. All parts are factory-adjusted. Improper adjustments may result in failure.
2. Be sure to energize the icemaker about 12 hours before initial start up or after prolonged shut down--otherwise, energize at least 1 hour before start up--to warm up the Compressor. Without this warm-up, the Compressor can be damaged.
3. If the unit is turned off, wait for at least 3 minutes before restarting the icemaker to prevent damage to the Compressor.
4. Do not operate the unit in the "WASH" position without water in the Water Tank. This will cause damage to the Water Pump seal.

- 1) Remove the Front Panel.
- 2) Make sure the Control Switch on the Control Box is in the "OFF" position.
- 3) Replace the Front Panel in its correct position.
- 4) Turn on the power supply, and leave the icemaker for about 12 hours to warm up the Compressor by the Crankcase Heater.
- 5) Turn off the power supply
- 6) Open the Water Supply Line Shut-off Valve
- 7) Remove the Front Panel.
- 8) Move the Control Switch to the "ICE" position.
- 9) Replace the Front Panel in its correct position
- 10) Turn on the power supply and allow the icemaker to operate for a total of 10 minutes.

Note: If miswiring causes excessive voltage on the Controller Board, the High Voltage Cut-out shuts down the circuit in 3 seconds and the icemaker automatically stops. When the proper supply voltage is resumed, the icemaker automatically starts running again.

- 11) Turn off the power supply, and remove the Front Panel.
- 12) Remove the Insulation Panel. Remove the Cap located on the front bottom part of the Ice Dropping Hole. Drain the Water Tank. See Fig. 12.
- 13) Replace the Cap, Insulation Panel and Front Panel in their correct positions.
- 14) Clean the Storage Bin.
- 15) Turn on the power supply, and start the automatic icemaking process.

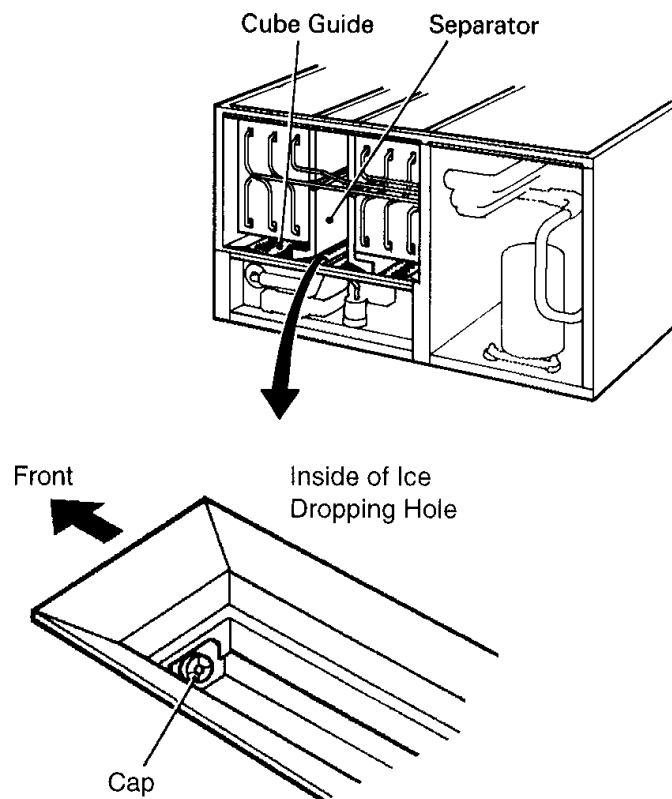

Fig. 12

11. PREPARING THE ICEMAKER FOR LONG STORAGE

IMPORTANT

When shutting off the icemaker for an extended time, drain out all water from the water tank and remove the ice from the Storage Bin. The Storage Bin should be cleaned and dried. Drain the icemaker using air or carbon dioxide to prevent damage to the water supply line at sub-freezing temperatures. Shut off the icemaker until the proper ambient temperature is resumed.

- When the icemaker is not used for two or three days, it is sufficient to only move the Control Switch to the "OFF" position, unless the icemaker will be at sub-freezing temperatures.

[1] Remove the water from the potable water supply line:

- 1) Remove the Front Panel.
- 2) Move the Control Switch, on the Control Box, to the "OFF" position.
- 3) Wait 3 minutes.
- 4) Close the Potable Water Supply Line Shut-off Valve and open the Potable Water Supply Line Drain Valve. See Fig. 12.
- 5) Allow the line to drain by gravity.
- 6) Quickly attach compressed air or carbon dioxide supply to the Potable Water Line Drain Valve.
- 7) Move the Control Switch to the "ICE" position.
- 8) Blow the potable water line out using compressed air or carbon dioxide.

[2] Drain the Potable Water Tank:

- 1) Turn off the Power Supply Switch.
- 2) Move the Control Switch, on the Control Box, to the "OFF" position.
- 3) Remove the Insulation Panel. Remove the Cap located on the front bottom part of the Ice Dropping Hole. Drain the Water Tank. See Fig. 12.
- 4) Replace the Cap and the Insulation Panel in their correct positions.
- 5) Remove all ice from the Storage Bin, and clean the Storage Bin.
- 6) Replace the Front Panel in its correct position.

III. CLEANING AND MAINTENANCE INSTRUCTIONS

IMPORTANT

Ensure all components, fasteners and thumbscrews are securely in place after any maintenance or cleaning is done to the equipment.

1. CLEANING INSTRUCTIONS

WARNING

1. HOSHIZAKI recommends cleaning this unit at least once a year. More frequent cleaning, however, may be required in some existing water conditions.
2. To prevent injury to individuals and damage to the icemaker, do not use ammonia type cleaners.
3. Always wear liquid-proof gloves for safe handling of the cleaning and sanitizing solution. This will prevent irritation from the solution coming into contact with skin.

IMPORTANT

1. The Cleaning Valve is used to provide access to the inside of the Evaporator during the cleaning and sanitizing operation. It should be closed for all icemaking operation. The Compressor will not operate unless this valve is completely closed.
2. To open the Cleaning Valve, the Valve Handle should be parallel to the valve body. To close the valve, the Valve Handle should be at a right angle to the valve body.

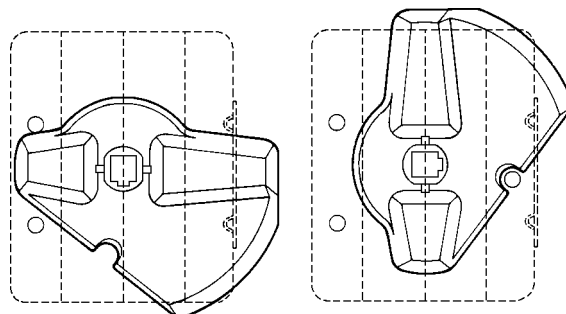

CLOSED POSITION

OPEN POSITION

[a] CLEANING PROCEDURE

- 1) Dilute approximately 38 fl. oz. of recommended cleaner Hoshizaki "Scale Away" or "LIME-A-WAY," (Economics Laboratory, Inc.) with 7 gal. of water.
- 2) Remove all ice from the Evaporator and the Storage Bin.

Note: To remove cubes on the Evaporator, turn off the power supply and turn it on after 3 minutes. The defrost cycle starts and the cubes will be removed from the Evaporator.
- 3) Turn off the power supply.
- 4) Remove the Front Panel, and then remove the Insulation Panel by first removing the Thumbscrew, lifting up the panel slightly and pulling it toward you.
- 5) Remove the Cap located on the front bottom part of the Ice Dropping Hole. Drain the Water Tank. See Fig. 13.
- 6) Replace the Cap in its correct position.
- 7) Pour the cleaning solution into the Water Tank.
- 8) Fully open the Cleaning Valve on the left side wall of the machine compartment.
- 9) Move the Control Switch, on the Control Box, to the "WASH" position
- 10) Replace the Insulation Panel and the Front Panel in their correct positions.
- 11) Turn on the power supply, and start the washing process.
- 12) Turn off the power supply after 30 minutes.
- 13) Remove the Front Panel and the Insulation Panel.
- 14) Remove the Cap located on the front bottom part of the Ice Dropping Hole. Drain the Water Tank. Replace the Cap and the Insulation Panel in their correct positions.
- 15) Move the Control Switch to the "ICE" position.
- 16) Close the Cleaning Valve.
- 17) Replace the Front Panel in its correct position.
- 18) Turn on the power supply to fill the Water Tank with water.
- 19) Turn off the power supply after 3 minutes.

- 20) Remove the Front Panel, and fully open the Cleaning Valve.
- 21) Move the Control Switch to the "WASH" position.
- 22) Replace the Front Panel in its correct position.
- 23) Turn on the power supply to rinse off the cleaning solution.
- 24) Turn off the power supply after 5 minutes.
- 25) Remove the Front Panel and the Insulation Panel.
- 26) Remove the Cap located on the front bottom part of the Ice Dropping Hole. Drain the Water Tank. Replace the Cap and the Insulation Panel in their correct positions.

Note: Do not replace the Insulation Panel when you proceed to
"[b] SANITIZING PROCEDURE."

- 27) Repeat the above steps 15) through 26) three more times to rinse thoroughly.

Note: If you do not sanitize the icemaker, go to the step 9) in
"[b] SANITIZING PROCEDURE."

[b] SANITIZING PROCEDURE - Following Cleaning Procedure

- 1) Dilute a 5.25% Sodium Hypochlorite solution (chlorine bleach) with water (Add 3.5 fl. oz. of sanitizer to 7 gal. of water).
- 2) Pour the sanitizing solution into the Water Tank.
- 3) Replace the Insulation Panel and the Front Panel in their correct positions.

Note: Make sure that the Control Switch is in the "WASH" position and the Cleaning Valve is open.

- 4) Turn on the power supply, and start the sanitizing process.
- 5) Turn off the power supply after 15 minutes.
- 6) Remove the Front Panel and the Insulation Panel.
- 7) Remove the Cap located on the front bottom part of the Ice Dropping Hole. Drain the Water Tank. Replace the Cap and the Insulation Panel in their correct positions.

- 8) Repeat the above steps 15) through 26) in "[a] CLEANING PROCEDURE" two times to rinse thoroughly.
- 9) Close the Cleaning Valve.
- 10) Move the Control Switch to the "ICE" position.
- 11) Replace the Front Panel in its correct position.
- 12) Clean the Storage Bin with water.
- 13) Turn on the power supply, and start the automatic icemaking process.

2. MAINTENANCE INSTRUCTIONS

IMPORTANT

This icemaker must be maintained individually, referring to the instruction manual and labels provided with the icemaker.

1) Stainless Steel Exterior

To prevent corrosion, wipe the exterior occasionally with a clean and soft cloth. Use a damp cloth containing a neutral cleaner to wipe off oil or dirt build up.

2) Storage Bin and Scoop

- Wash your hands before removing ice. Use the plastic scoop provided (Bin Accessory).
- The Storage Bin is for ice use only. Do not store anything else in the bin.
- Keep the scoop clean. Clean it by using a neutral cleaner and rinse thoroughly.
- Clean the bin liner by using a neutral cleaner. Rinse thoroughly after cleaning.

3) Condenser

Check the Condenser once a year, and clean if required by using a brush or vacuum cleaner. More frequent cleaning may be required depending on the location of the icemaker.

HOSHIZAKI

HOSHIZAKI AMERICA, INC.

**618 HIGHWAY 74 SOUTH
PEACHTREE CITY, GA 30269
U.S.A.**

PHONE: 770-487-2331

91A1PB10B