



# HOSHIZAKI

## Parts List

Stackable Crescent Cuber

Models

KM-130ISAJ/3

KM-130ISWJ/3

KM-130ISRJ(Z)/3



[hoshizakiamerica.com](http://hoshizakiamerica.com)

Number: 71383  
Issued: 6-29-2017  
Revised: 1-8-2025

## CONTENTS

Auxiliary Codes.....	3
Note About Ordering Parts .....	4
A. Main Assembly & Refrigeration Circuit .....	5
KM-1301SAJ/3.....	5
KM-1301SWJ/3.....	9
KM-1301SRJ(Z)/3.....	13
B. Water Circuit .....	17
C. Control Box Assembly .....	21
D. Accessories & Labels .....	25

## Auxiliary Codes

### **KM-1301SAJ**

G-0 February 2017  
G-1 September 2017  
H-0 January 2018  
J-0 January 2019  
J-1 April 2019  
K-0 January 2020  
L-0 January 2021  
M-0 January 2022  
N-0 January 2023  
N-1 May 2023  
N-2 June 2023  
N-3 September 2023  
P-0 January 2024  
P-2 April 2024  
P-3 August 2024  
P-4(J) September 2024

### **KM-1301SAJ3**

G-0 February 2017  
G-1 September 2017  
H-0 January 2018  
J-0 January 2019  
J-1 April 2019  
K-0 January 2020  
L-0 January 2021  
M-0 January 2022  
N-0 March 2023  
N-1 May 2023  
N-2 June 2023  
N-3 September 2023  
P-0 January 2024  
P-2 April 2024

### **KM-1301SWJ**

G-0 February 2017  
G-1 September 2017  
H-0 January 2018  
J-0 January 2019  
J-1 April 2019  
K-0 January 2020  
L-0 January 2021  
M-0 January 2022  
N-0 March 2023  
N-1 May 2023  
N-2 July 2023  
N-3 September 2023  
P-0 January 2024  
P-2 April 2024  
P-3 October 2024

### **KM-1301SWJ3**

G-0 February 2017  
G-1 September 2017  
H-0 January 2018  
J-0 January 2019  
J-1 April 2019  
K-0 January 2020  
L-0 February 2021  
M-0 January 2022  
N-0 March 2023  
N-1 May 2023  
N-2 July 2023  
P-0 January 2024  
P-2 April 2024

### **KM-1301SRJ**

G-0 February 2017  
G-1 September 2017  
H-0 January 2018  
J-0 January 2019  
J-1 April 2019  
K-0 January 2020  
L-0 January 2021

### **KM-1301SRJZ**

M-0 January 2022  
N-0 January 2023  
N-1 May 2023  
N-2 June 2023  
N-3 September 2023  
P-0 January 2024  
P-2 April 2024  
P-3 August 2024  
P-4(J) September 2024

### **KM-1301SRJ3**

G-0 February 2017  
G-1 September 2017  
H-0 January 2018  
J-0 February 2019  
J-1 April 2019  
K-0 January 2020  
L-0 January 2021

### **KM-1301SRJZ3**

M-0 January 2022  
N-0 March 2023  
N-1 May 2023  
N-2 June 2023  
N-3 October 2023  
P-0 January 2024  
P-2 April 2024

## **Auxiliary Code Breakdown**

The auxiliary code is the first two characters in the serial number. The first character indicates the year. Years progress or regress in alphabetical order. The series runs from "A" through "V" and the letters "I" and "O" are skipped. The second character indicates significant part changes within a year. Base is "0" and this number advances for each change. In cases where there is a letter in parentheses, this designates the month. This is the last character in the serial number. The series runs from "(A)" through "(M)" and the letter "(I)" is skipped. This designation is only included when identifying a parts change within an auxiliary code.

## **Note About Ordering Parts**

Most assemblies cannot be ordered as complete units; parts in the assemblies generally must be ordered separately.

**A. Main Assembly & Refrigeration Circuit**  
**KM-1301SAJ/3**  
**1/2**  
 G-0 to N-3(J)

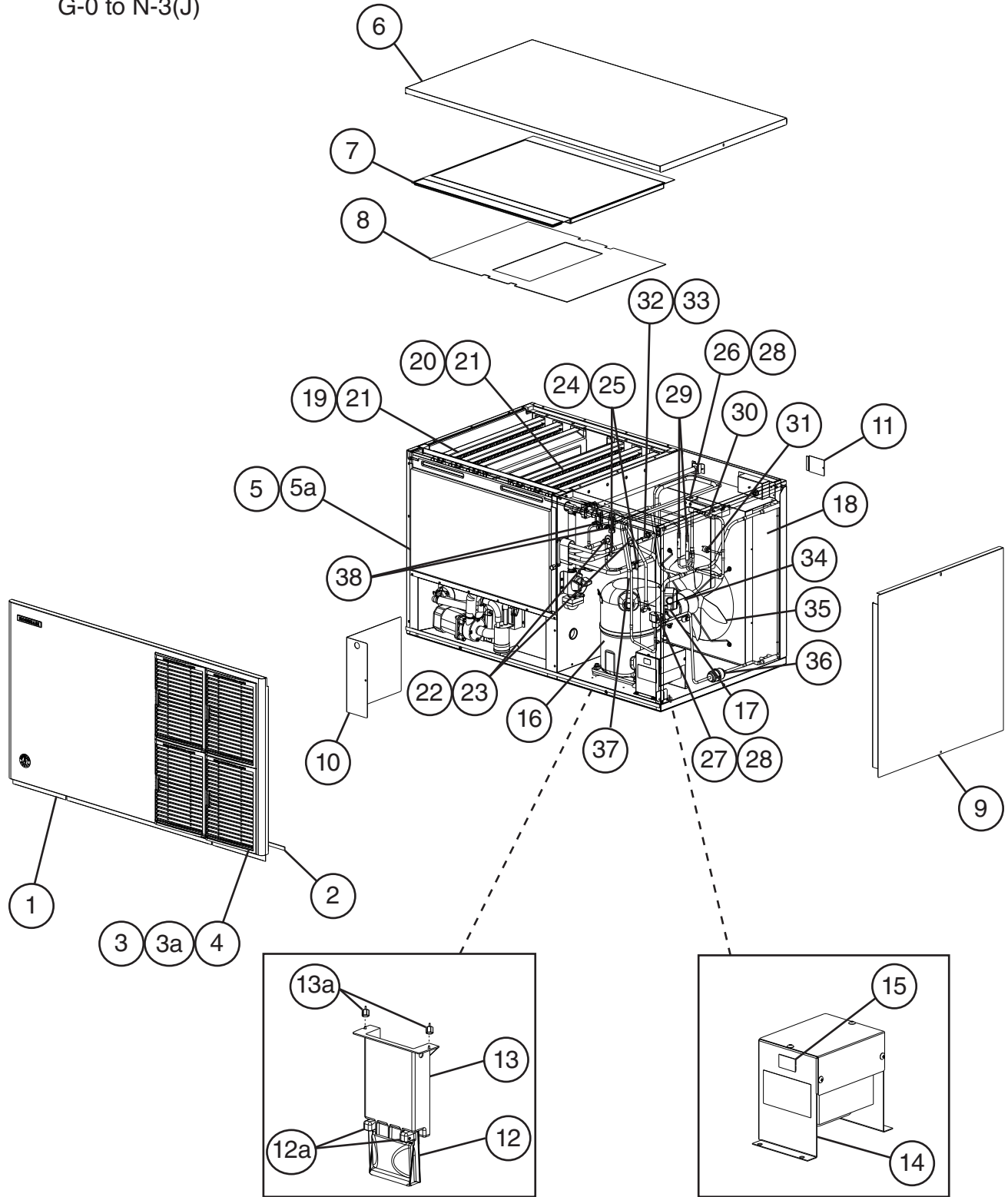

**A. Main Assembly & Refrigeration Circuit**  
**KM-1301SAJ/3**  
**2/2**  
 N-3(K) to P-4

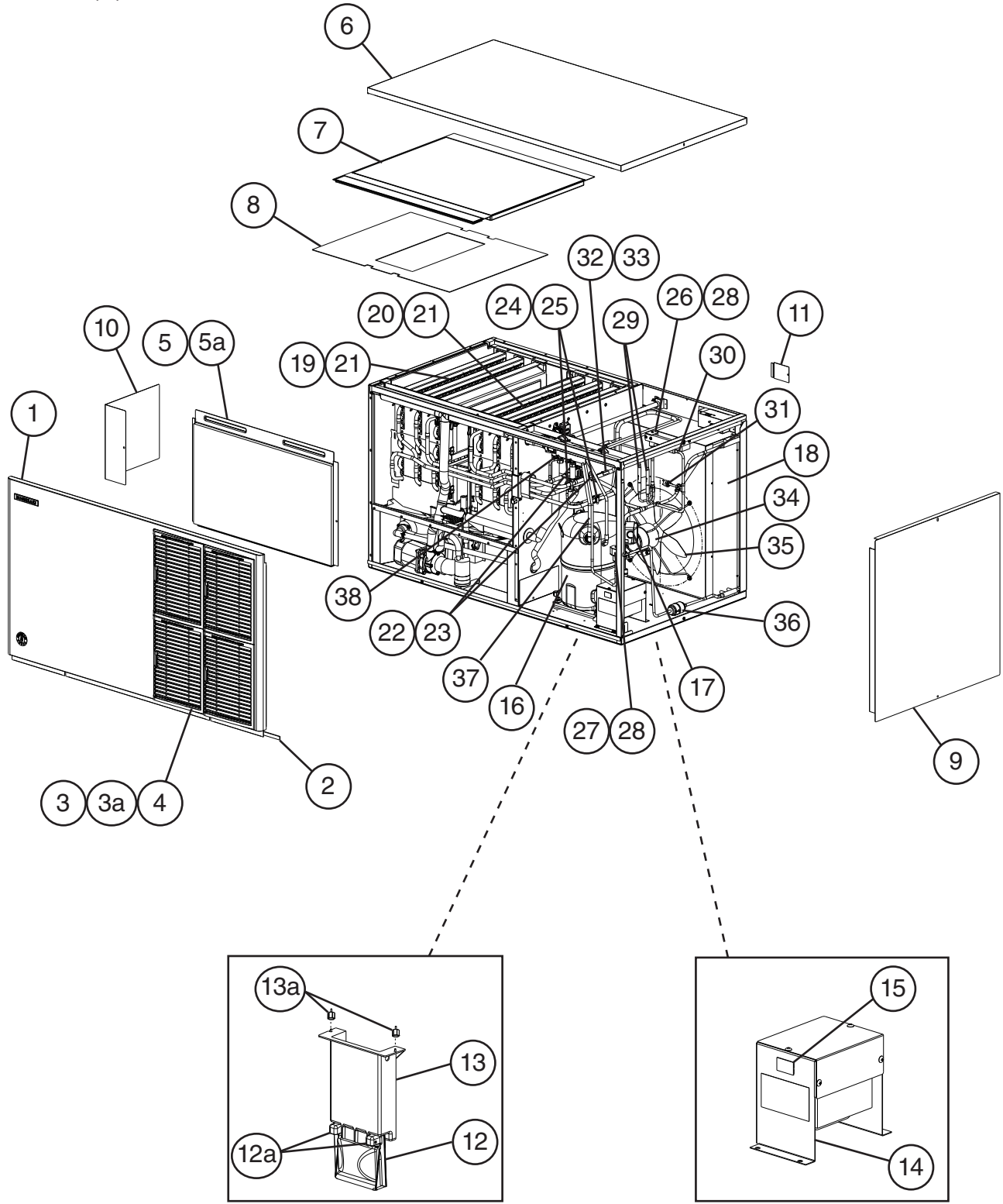

Title: A. Ice Cuber Assembly & Refrigeration Circuit											Model: KM-1301SAJ/3									
Index No.	Description	Material or Model Number	Part Number	Required Number																
				G-0 to N-3 (J)	N-3 (K) to P-2	P-3 P-4														
<b>Main Assembly</b>																				
1	Front Panel Assembly		3B1139G02	1	-															
			3B2117G02		1	1														
2	Gasket	L=1219 mm	4A0808L02	1	1	1														
3	Louver		1A0548-01	4	4	4														
3a	Push Retainer		4A2414-01	12																
4	Air Filter		2A2063G01	4	4	4														
5	Front Insulation		324215G01	1	1	1														
5a	Thumbscrew		415949G12	1	1	1														
6	Top Panel		2A2255-01	1	1	1														
7	Top Insulation		324216G01	1	1	1														
8	Spacer		324321-01	1	1	1														
9	Right Side Panel		2A2226G01	1	1	1														
10	Control Box Cover		3A2386-03	1	-															
			3B1942-01		1	1														
11	Junction Box Cover		433410-01	1	1	1														
12	Mechanical Bin Control		2A8598G01	1	1	1														
12a	Thumbscrew		415949G12	2	2	2														
13	Bin Control Extension Bracket		3A5726-01	1	1	1														
13a	Thumbscrew		415949G12	2	2	2														
14	Main Transformer		4A5695-01	1	1	1														
15	Voltage Tap Switch		4A1477-01	1	1	1														
<b>Refrigeration Circuit</b>																				
16	Compressor	<b>KM-1301SAJ</b>	4A1412-03	1	1	1														
		<b>KM-1301SAJ3</b>	4A1484-03	1	1	1														
17	Compressor Wire Harness		1A4899-01		1	1														
18	Condenser		2A7966-01	1	1	1														
19	Left Evaporator Bank Assembly (includes 4 of item 21)		SP-5430	1	1	1														
20	Right Evaporator Bank Assembly (includes 4 of item 21)		SP-5431	1	1	1														
21	Separator Hook		324152-01	8	8	8														
22	Thermostatic Expansion Valve		4A1482-01	2	2	2														
23	Thermostatic Expansion Valve Cover		3A0944-01	2	2	2														
24	Thermostatic Expansion Valve Bulb Holder		3A0107-01	2	2	2														
25	Clamp		443461-02	2	2	2														
26	Hot Gas Valve Body		4A3978-01	1	1	1														
27	Liquid Line Valve Body		4A3276-01	1	1	1														
28	Valve Coil		4A3277-01	2	2	2														
29	Check Valve		4A1373-01	2	2	2														
30	Strainer		441569-04	1	1	1														
31	High-Pressure Switch		463180-01	1	1	1														
32	Thermistor		429006-03	1	1	1														
33	Thermistor Holder		427430-01	1	1	1														

Title: A. Ice Cuber Assembly & Refrigeration Circuit Model: KM-1301SAJ/3											
Index No.	Description	Material or Model Number	Part Number	Required Number							
				G-0 to N-3 (J)	N-3 to P-2 (K)	P-3 P-4					
34	Fan Motor		4A3158-01	1	1	1					
35	Fan Blade		4A0197-01	1	1	1					
36	Drier		4A1113-01	1	1	1					
37	Heat Exchanger		2A7978G01	1	1	-					
			2A9000G01			1					
38	Service Valve		4A3420-01	2	2	2					



**A. Main Assembly & Refrigeration Circuit**  
**KM-1301SWJ/3**  
**1/2**  
 G-0 to N-3(J)

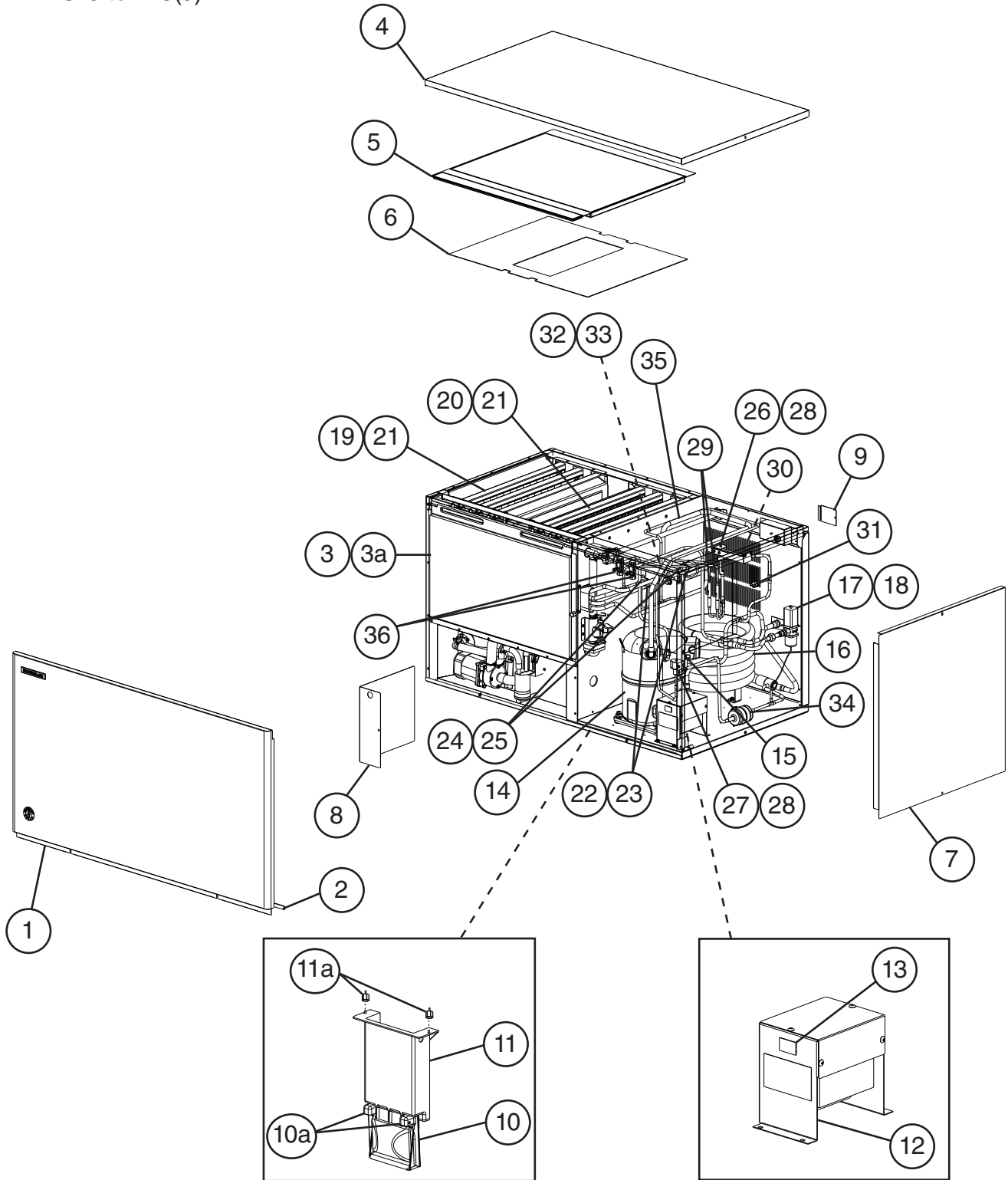

**A. Main Assembly & Refrigeration Circuit**  
**KM-1301SWJ/3**  
**2/2**  
 N-3(K) to P-3

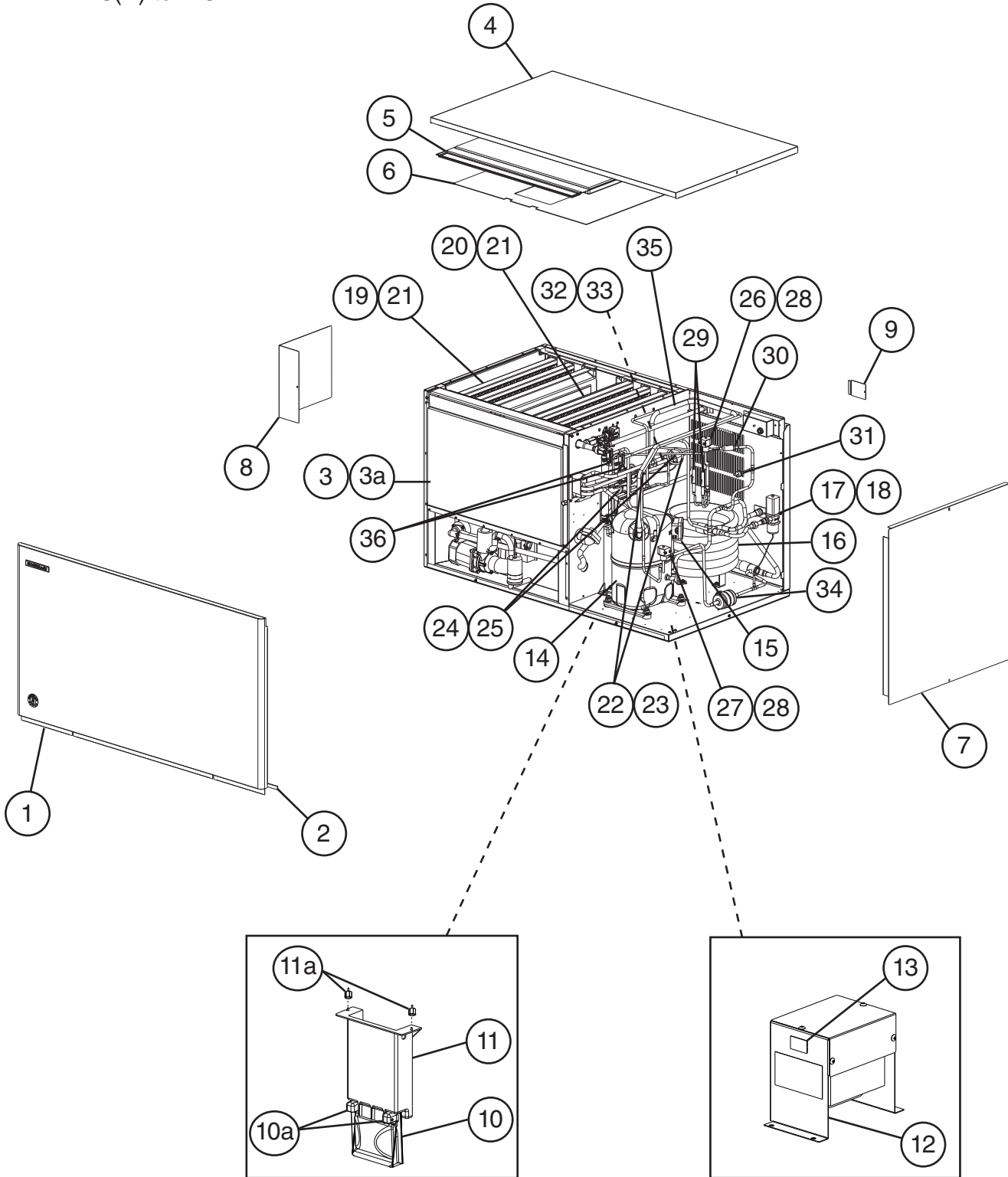

For Bin Control Thermostat,  
 see "C. Control Box Assembly"

Title: A. Main Assembly & Refrigeration Circuit Model: KM-1301SWJ/3											
Index No.	Description	Material or Model Number	Part Number	Required Number							
				G-0 to N-3 (J)	N-3 (K) to P-3						
<b>Main Assembly</b>											
1	Front Panel		3B1139G01	1	-						
			3A1969G01		1						
2	Gasket	L=1219 mm	4A0808L02	1	1						
3	Front Insulation		324215G01	1	1						
3a	Thumbscrew		415949G12	1	1						
4	Top Panel		2A2255-01	1	1						
5	Top Insulation		324216G01	1	1						
6	Spacer		324321-01	1	1						
7	Right Side Panel		2A2226G01	1	1						
8	Control Box Cover		3A2386-03	1	-						
			3B1942-01		1						
9	Junction Box Cover		433410-01	1	1						
10	Mechanical Bin Control		2A8598G01	1	1						
10a	Thumbscrew		415949G12	2	2						
11	Bin Control Extension Bracket		3A5726-01	1	1						
11a	Thumbscrew		415949G12	2	2						
12	Main Transformer		4A5695-01	1	1						
13	Voltage Tap Switch		4A1477-01	1	1						
<b>Refrigeration Circuit</b>											
14	Compressor	KM-1301SWJ	4A4134-03	1	1						
			KM-1301SWJ3	4A4135-03	1	1					
15	Compressor Harness		1A4899-01		1						
16	Water-Cooled Condenser		3A7324-01	1	1						
17	Water Regulating Valve		4A0911-07	1	1						
18	Male Connector		4A1087-01	1	1						
19	Left Evaporator Bank Assembly (includes 4 of item 21)		SP-5430	1	1						
20	Right Evaporator Bank Assembly (includes 4 of item 21)		SP-5431	1	1						
21	Separator Hook		324152-01	8	8						
22	Thermostatic Expansion Valve		4A1482-01	2	2						
23	Thermostatic Expansion Valve Cover		3A0944-01	2	2						
24	Thermostatic Expansion Valve Bulb Holder		3A0107-01	2	2						
25	Clamp		443461-02	2	2						
26	Hot Gas Valve Body		4A3978-01	1	1						
27	Liquid Line Valve Body		4A3276-01	1	1						
28	Valve Coil		4A3277-01	2	2						
29	Check Valve		4A1373-01	2	2						
30	Strainer		441569-04	1	1						
31	High-Pressure Switch		463180-05	1	1						
32	Thermistor		429006-03	1	1						

Title: A. Main Assembly & Refrigeration Circuit    Model: KM-1301SWJ/3											
Index No.	Description	Material or Model Number	Part Number	Required Number							
				G-0 to N-3 (J)	N-3 (K) to P-3						
33	Thermistor Holder		438247-01	1	1						
34	Drier		4A1338-01	1	1						
35	Heat Exchanger		1A4295G01	1	1						
36	Service Valve		4A3420-01	2	2						

**A. Main Assembly & Refrigeration Circuit**  
**KM-1301SRJ(Z)/3**  
**1/2**  
 G-0 to N-3(J)

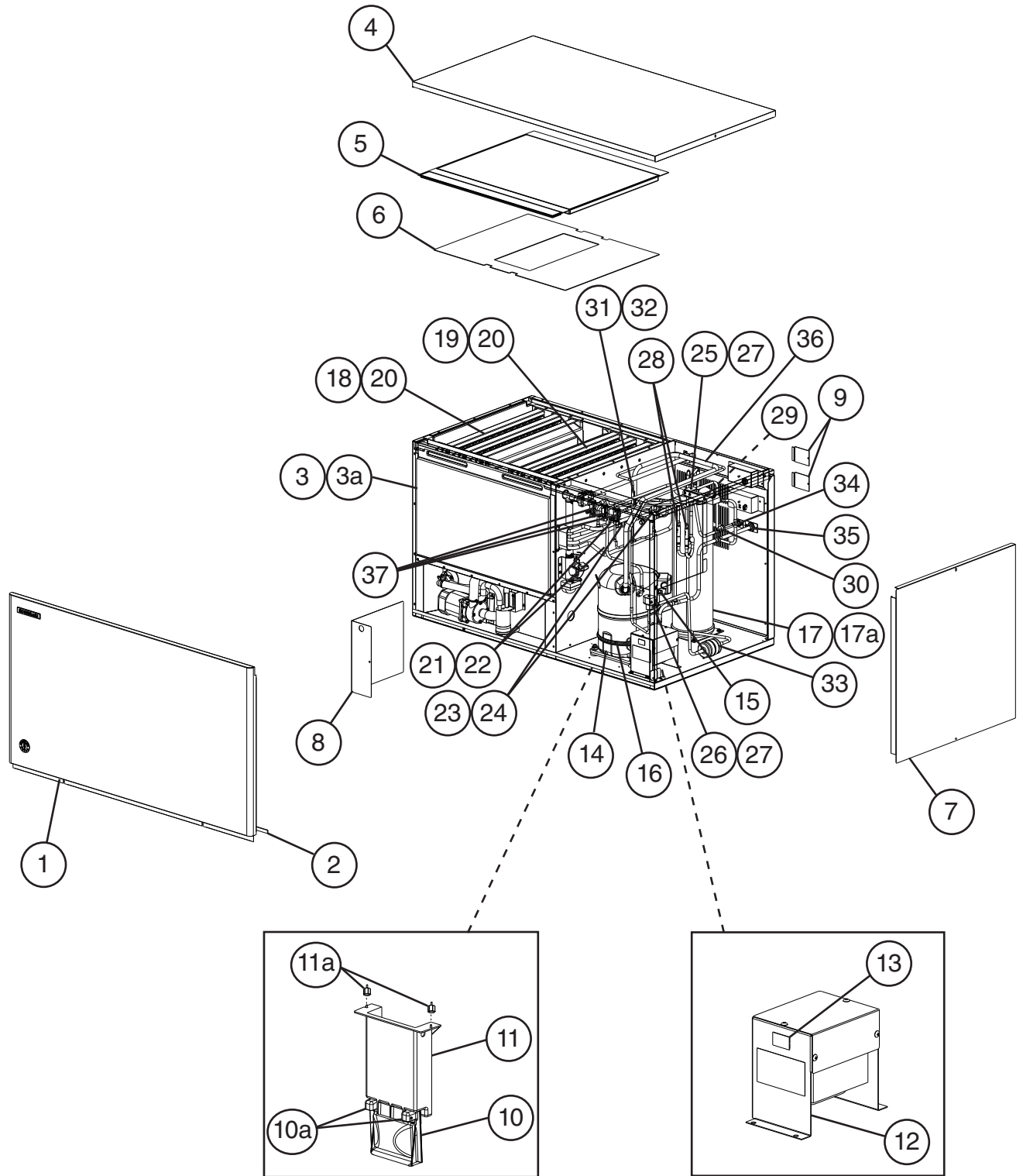

**A. Main Assembly & Refrigeration Circuit**  
**KM-1301SRJ(Z)/3**  
**2/2**  
 N-3(K) to P-4

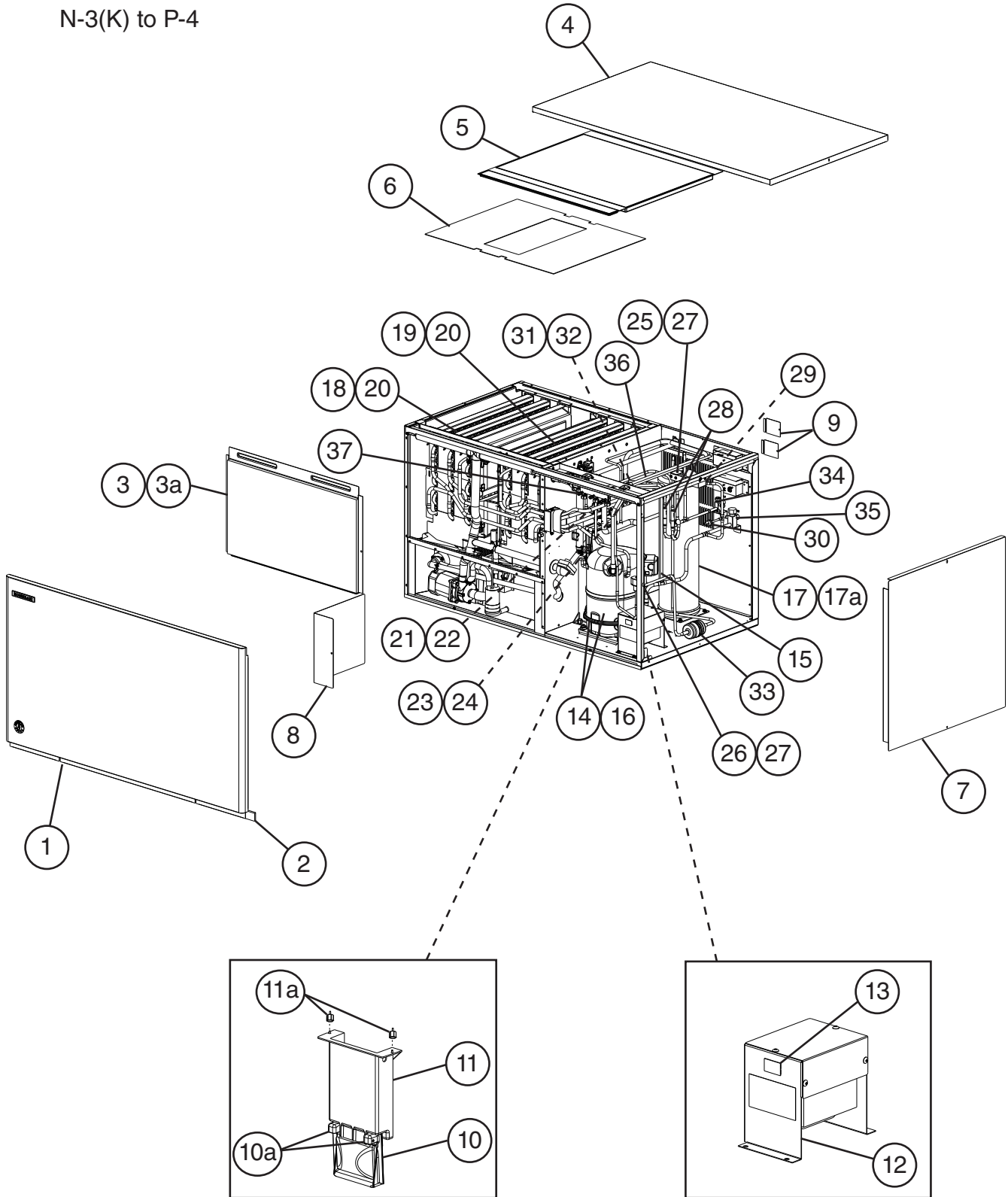

Title: A. Main Assembly & Refrigeration Circuit Model: KM-1301SRJ(Z)/3										
Index No.	Description	Material or Model Number	Part Number	Required Number						
				G-0 to L-0	M-0 to N-3 (J)	N-3 (K) to P-4				
<b>Main Assembly</b>										
1	Front Panel		3B1139G01	1	1	-				
			3A1969G01			1				
2	Gasket	L=1219 mm	4A0808L02	1	1	1				
3	Front Insulation		324215G01	1	1	1				
3a	Thumbscrew		415949G12	1	1	1				
4	Top Panel		2A2255-01	1	1	1				
5	Top Insulation		324216G01	1	1	1				
6	Spacer		324321-01	1	1	1				
7	Right Side Panel		2A2226G01	1	1	1				
8	Control Box Cover		3A2386-03	1	1	-				
			3B1942-01			1				
9	Junction Box Cover		433410-01	2	2	2				
10	Mechanical Bin Control		2A8598G01	1	1	1				
10a	Thumbscrew		415949G12	2	2	2				
11	Bin Control Extension Bracket		3A5726-01	1	1	1				
11a	Thumbscrew		415949G12	2	2	2				
12	Main Transformer		4A5695-01	1	1	1				
13	Voltage Tap Switch		4A1477-01	1	1	1				
<b>Refrigeration Circuit</b>										
14	Compressor	KM-1301SRJ(Z)	4A4134-03	1	1	1				
		KM-1301SRJ(Z)3	4A4135-03	1	1	1				
15	Compressor Wire Harness		1A4899-01			1				
16	Crankcase Heater		4A5397-02	1	1	1				
17	Receiver Tank		4A6215-01	1	1	1				
17a	Hex Bolt	5x10	7B0130510	3	3	3				
18	Left Evaporator Bank Assembly (includes 4 of item 20)		SP-5430	1	1	1				
19	Right Evaporator Bank Assembly (includes 4 of item 20)		SP-5431	1	1	1				
20	Separator Hook		324152-01	8	8	8				
21	Thermostatic Expansion Valve		4A1482-01	2	2	2				
22	Thermostatic Expansion Valve Cover		3A0944-01	2	2	2				
23	Thermostatic Expansion Valve Bulb Holder		3A0107-01	2	2	2				
24	Clamp		443461-02	2	2	2				
25	Hot Gas Valve Body		4A3978-01	1	1	1				
26	Liquid Line Valve Body		4A3276-01	1	1	1				
27	Valve Coil		4A3277-01	2	2	2				
28	Check Valve		4A2054-01	2	2	2				
29	Strainer		441569-04	1	1	1				
30	High-Pressure Switch		463180-04	1	1	1				
31	Thermistor		429006-03	1	1	1				
32	Thermistor Holder		438247-01	1	1	1				

Title: A. Main Assembly & Refrigeration Circuit Model: KM-1301SRJ(Z)/3											
Index No.	Description	Material or Model Number	Part Number	Required Number							
				G-0 to L-0	M-0 to N-3 (J)	N-3 (K) to P-4					
33	Drier		4A2663-01	1	1	1					
34	Liquid Line Coupling		433751G01	1	-						
	Liquid Line Service Valve		4A3491-01		1	1					
35	Discharge Line Coupling		434072-01	1	-						
	Discharge Line Service Valve		4A4822-01		1	1					
36	Heat Exchanger		1A4295G01	1	1	1					
37	Service Valve		4A3420-01	3	3	3					



**B. Water Circuit**  
**KM-1301S\_J(Z)/3**  
**1/2**  
 G-0 to N-3(J)

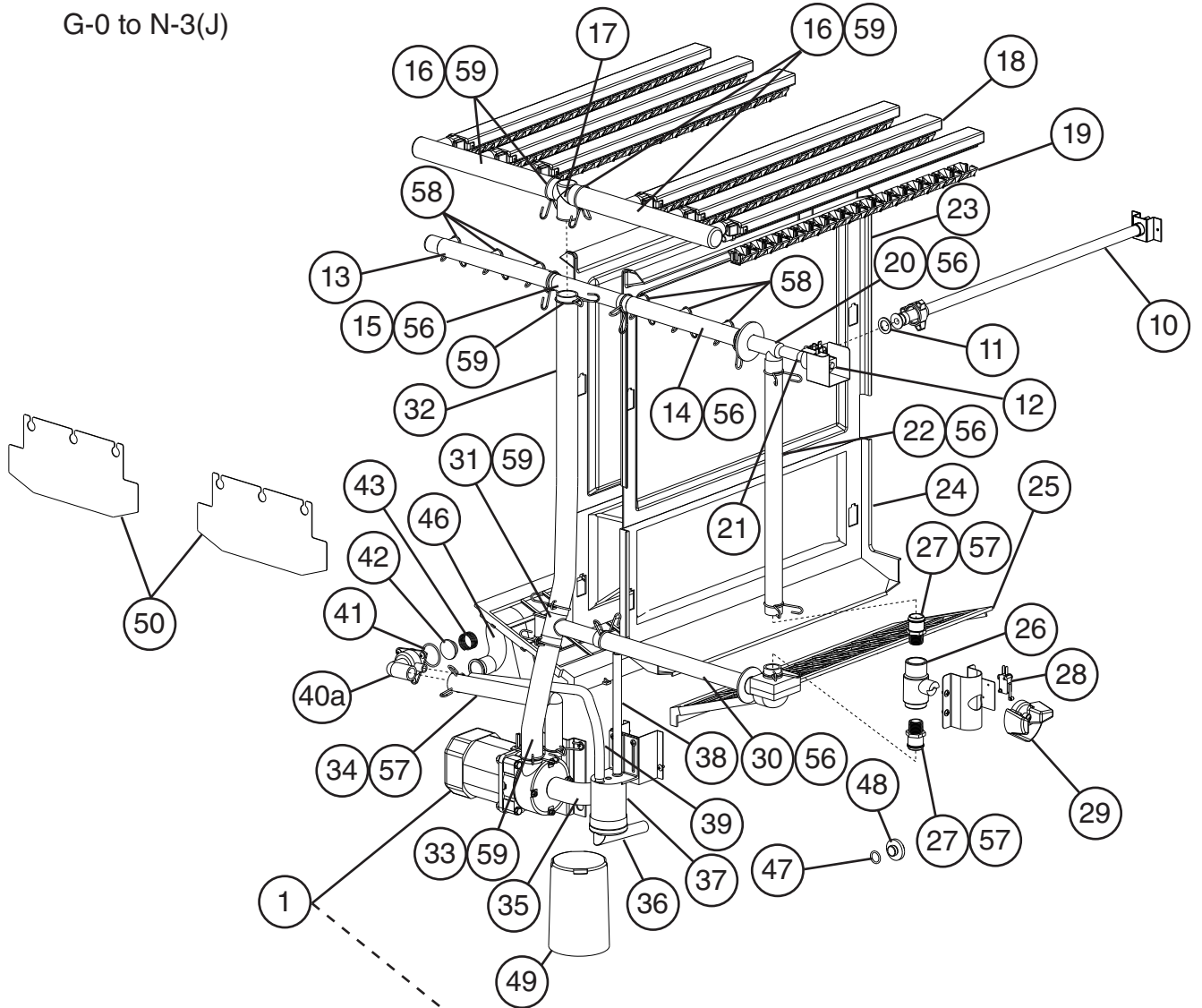

**Pump Motor Assembly**

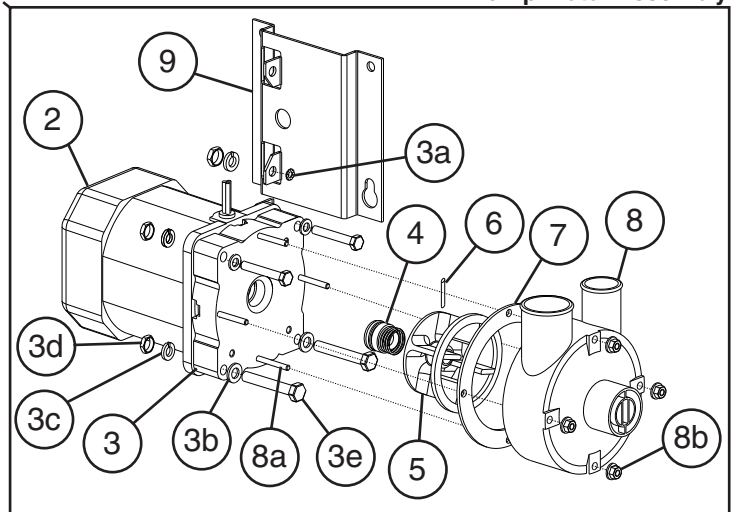

**B. Water Circuit**  
**KM-1301S\_J(Z)/3**  
**2/2**  
 N-3(K) to P-4

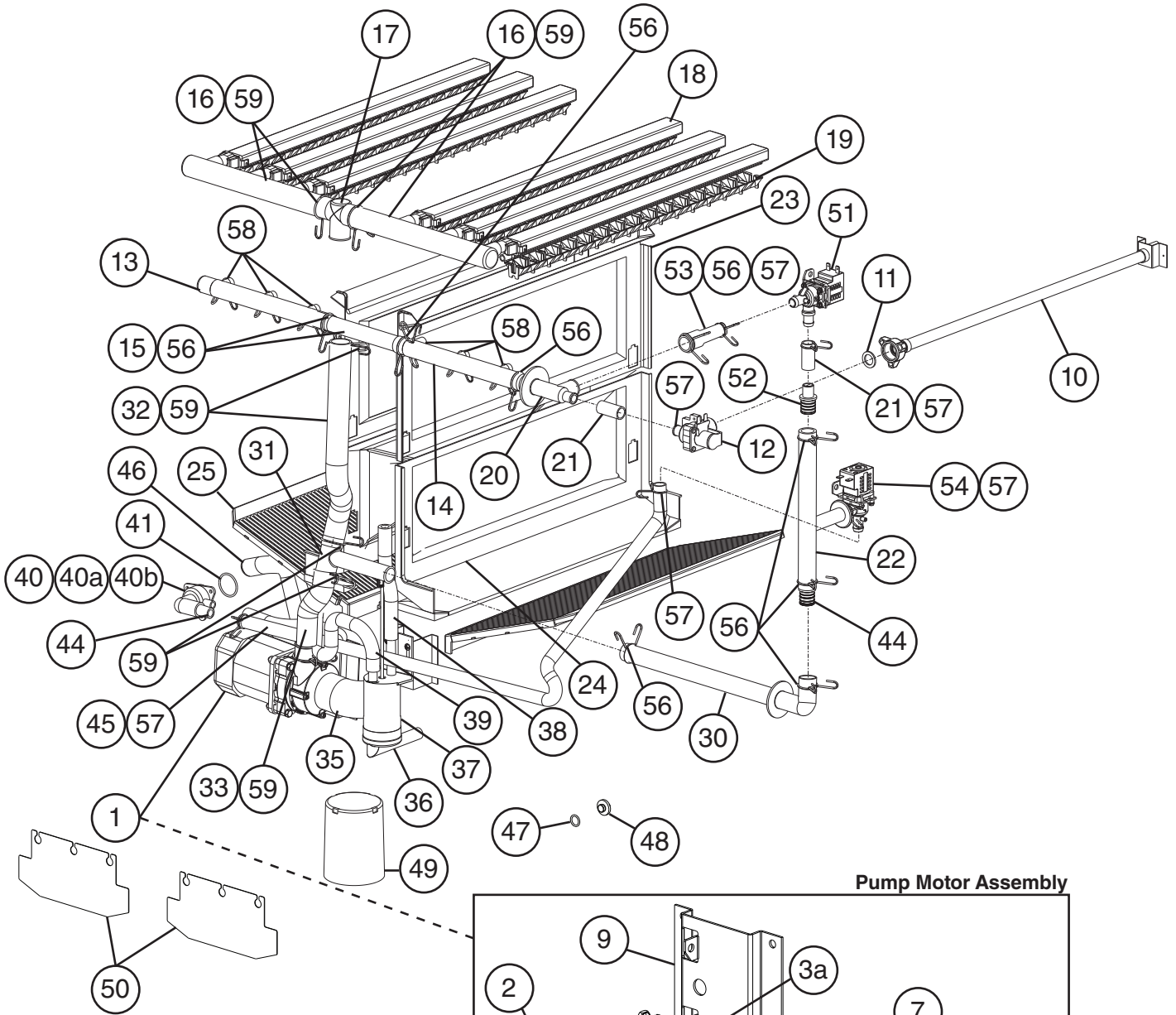

**Pump Motor Assembly**

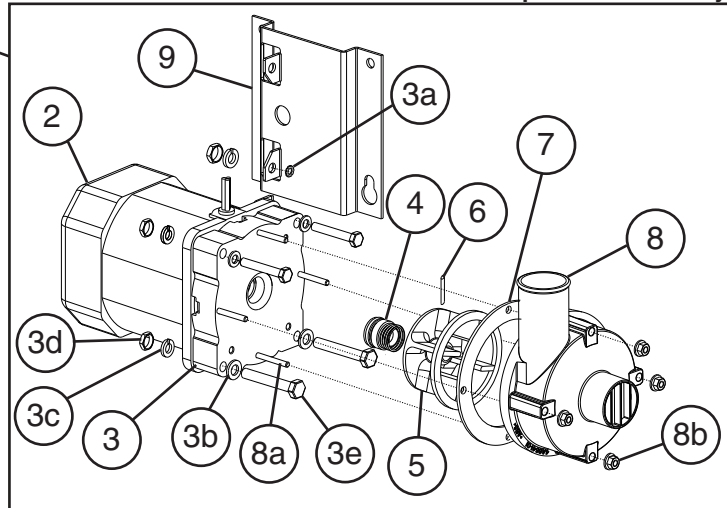

**Title: B. Water Circuit Model: KM-1301S\_J(Z)/3**

Index No.	Description	Material or Model Number	Part Number	Required Number																
				G-0 to N-3 (J)	N-3 (K) to P-0	P-2 to P-4														
1	Pump Motor Assembly (includes items 2 through 9)	S-0730	215692A03	1	-															
			2B0567A01		1	1														
2	Pump Motor		4A7462-01	1	1	1														
3	Pump Flange		215662-01	1	1	1														
3a	Tooth Washer		7R22-0600	2	2	2														
3b	Flat Washer		7W22-0600	4	4	4														
3c	Split Lock Washer		7L22-0600	4	4	4														
3d	Hex Nut		7N12-0600	4	4	4														
3e	Hex Head Bolt	6x40	7B02-0640	4	4	4														
4	Mechanical Seal		4A3820-03	1	1	1														
5	Impeller		436584-01	1	1	1														
6	Pin		4A0648-01	1	1	1														
7	Packing		428547-01	1	1	1														
8	Pump Motor Housing		213687-01	1	-															
			4A6641-01		1	1														
8a	Hex Head Bolt	4x55	7B02-0455	4	4	4														
8b	Hex Flange Nut		7J02-0400	4	4	4														
9	Pump Motor Bracket		323904-01	1	1	1														
10	Water Supply Pipe		4A5216G04	1	1	1														
11	Rubber Gasket		4A7594-01	1	1	1														
12	Inlet Water Valve		3Uo111-01	1	1	-														
			3B1433-01			1														
13	Distributor Hose A		325738-01	1	1	1														
14	Distributor Hose B		325738-02	1	1	1														
15	Joint Pipe		439297-01	1	1	1														
16	Distributor Hose C		325739-01	2	2	2														
17	Distributor A (Tee)		439266-01	1	1	1														
18	Spray Tube		437049G01	6	6	6														
19	Spray Guide		2A4282-02	6	6	6														
20	Distributor B (Tee)		439239-01	1	1	1														
21	Vinyl Hose	L= 80 mm	7716-1216	1	-															
		L= 40 mm	7716B1216		2	2														
22	Joint Hose		439309-02	1	-															
			2A8823-01		1	1														
23	Separator A		213622-01	2	2	2														
24	Separator B		2A0100-01	2	2	2														
25	Cube Guide		214243-01	2	2	2														
26	Cleaning Valve Ball Valve		439293-01	1	-															
27	Cleaning Valve Male Adapter		325826-01	2	-															
28	Cleaning Valve Microswitch		4A2546-01	1	-															
29	Cleaning Valve Handle		215383-01	1	-															
30	Bypass Hose		439237-02	1	1	1														
31	Distributor C (Tee)		439238-01	1	1	1														
32	Vinyl Hose	L= 385 mm	7716B2732	1	-															
		L= 350 mm	7716B2732		1	1														
33	Vinyl Hose	L= 170 mm	7716B2732	1	1	1														

Title: B. Water Circuit Model: KM-1301S_J(Z)/3											
Index No.	Description	Material or Model Number	Part Number	Required Number							
				G-0 to N-3 (J)	N-3 (K) to P-0	P-2 to P-4					
34	Hose B (drain hose)		436599-01	1	-						
35	Hose A (pump inlet hose)		435091-01	1	1	1					
36	Float Switch Connector		426799-04	1	1	1					
37	Float Switch Assembly		4A7077G01	1	1	1					
38	Silicone Hose (float switch vent hose)	L= 140 mm	773013896	1	1	1					
39	Silicone Hose (float switch cleaning hose)	L= 390 mm	773013896	1	-						
		L= 365 mm			1	1					
40	Drain Housing Assembly (Includes items 40a and 40b)		3B1598G01		1	1					
40a	Drain Valve Housing		323613-01	1	1	1					
40b	Joint Pipe		4A6286-01		1	1					
41	Drain Valve O-Ring		7611-G035	1	1	1					
42	Drain Valve Seat		433705-01	1	-						
43	Drain Valve Spring		322110-01	1	-						
44	Adapter Fitting		2A8823-03		1	1					
45	Vinyl Hose	L= 930 mm	7716B1519		1	1					
46	Drain Hose		324757-01	1	-						
		<b>SP-5728</b>	325867-02		1	1					
47	Drain Plug O-Ring		7611-P015	1	1	1					
48	Drain Plug		309246-01	1	1	1					
49	Overflow Cap		323978-01	1	1	1					
50	Splash Guard		4A6116-01	2	2	2					
51	Cleaning Valve		4A5745-06		1	1					
52	Hose Barb		4A7351-01		1	1					
53	Vinyl Hose (cleaning valve outlet hose)	L= 60 mm	3B1462-01		1	1					
54	Drain Valve		4A5745-07		1	1					
<b>Hose Clamps</b>											
56	Hose Clamp	25 mm	427443-03	9	9	9					
57	Hose Clamp	18 mm	427443-05		6	6					
58	Hose Clamp	13.5 mm	427443-07	6	6	6					
59	Hose Clamp	32 mm	427443-09	6	6	6					

# C. Control Box Assembly

## KM-1301S\_J(Z)/3

1/2

G-0 to N-3(J)

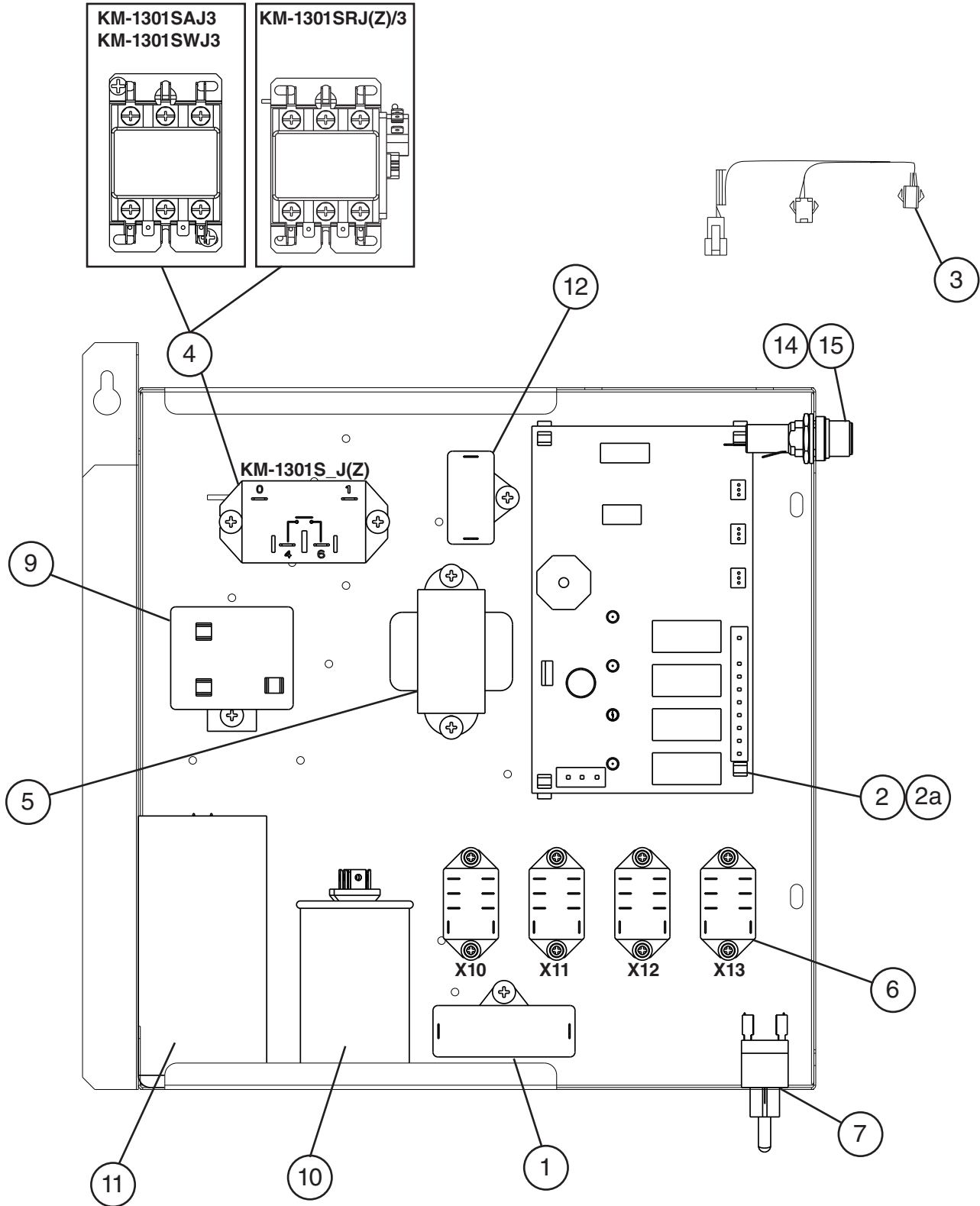

**C. Control Box Assembly**  
**KM-1301S\_J(Z)/3**  
**2/2**  
 N-3(K) to P-4

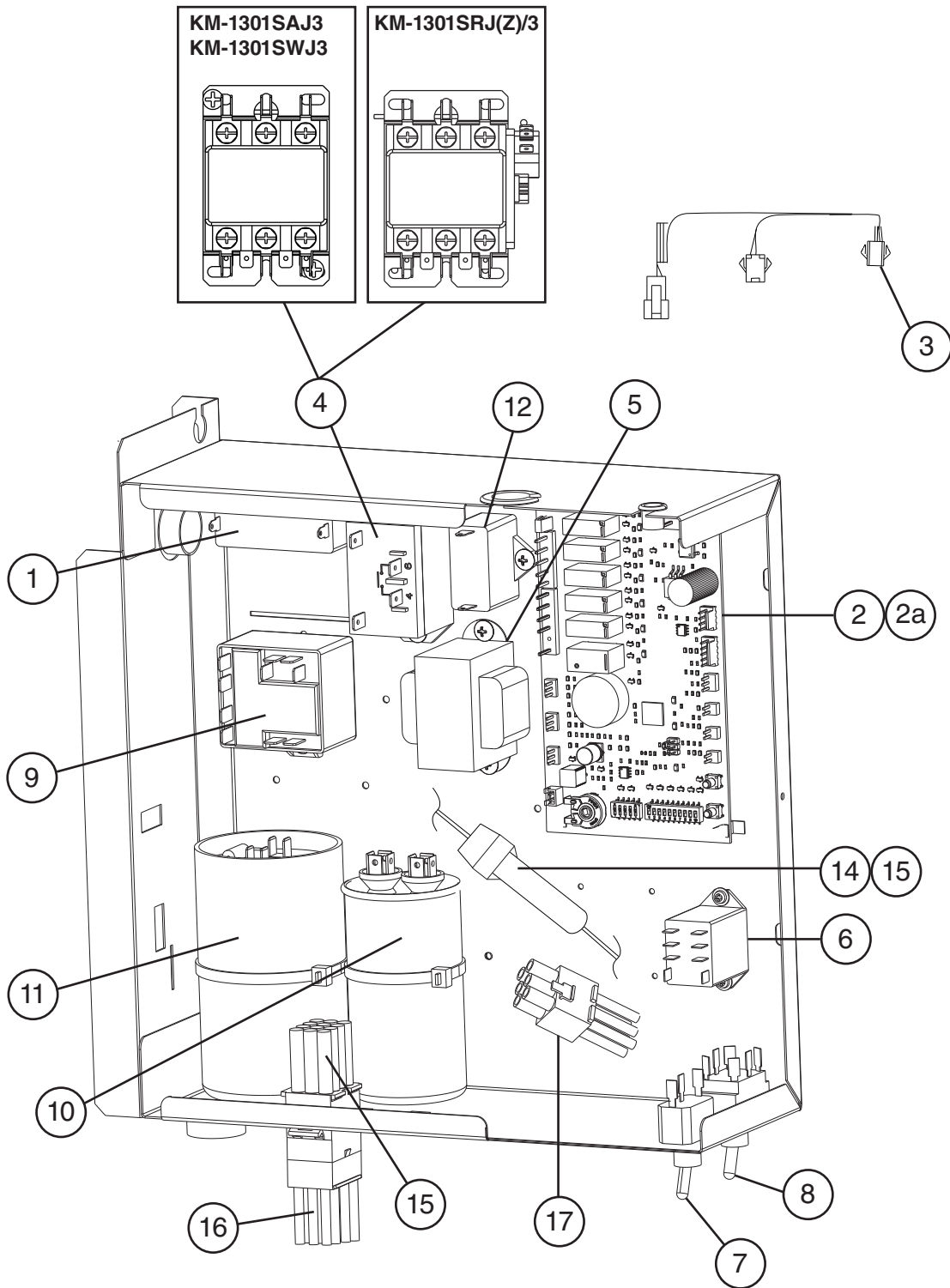

Title: C. Control Box Assembly Model: KM-1301S_J(Z)/3										
Index No.	Description	Material or Model Number	Part Number	Required Number						
				G-0 to N-3 (J)	N-3 (K) to P-4					
1	Pump Motor Capacitor	15MFD, 240VAC	439705-01	1	1					
2	Control Board		2A7664-04	1	-					
			2A9678-01		1					
2a	Control Board Support		4A0336-03	4	4					
3	Wire Harness	<b>KM-1301SAJ/3</b> <b>KM-1301SWJ/3</b> <b>KM-1301SRJZ/3</b>	4A6973G01	1	1					
		<b>KM-1301SRJ(Z)</b>	4A5197G01		1					
4	Compressor Relay	<b>KM-1301S_J(Z)</b>	4A3140-01	1	1					
	Magnetic Contactor	<b>KM-1301SAJ3</b> <b>KM-1301SWJ3</b>	4A0794-02	1	1					
		<b>KM-1301SRJ(Z)/3</b>	4A0794-01	1	1					
5	Control Transformer		3A0172-01	1	1					
6	Relay X10=Pump Direction Relay X11=X10 Control Relay X12=Slush Control Relay	<b>All Models</b>	406132-07	3	-					
	X13=Crankcase Heater Relay	<b>KM-1301SRJ(Z)</b>		1	-					
	X10=Crankcase Heater Relay	<b>KM-1301SRJZ</b>			1					
7	Control Switch		443119-01	1	-					
			4A0985-01		1					
8	Mode Switch		4A6232-01		1					
9	Start Relay	<b>KM-1301SAJ</b>	4A1107-09	1	1					
		<b>KM-1301SWJ</b> <b>KM-1301SRJ(Z)</b>	4A1107-13	1	1					
10	Run Capacitor	<b>KM-1301SAJ</b> 35MFD, 370VAC	3A2005-05	1	1					
		<b>KM-1301SWJ</b> <b>KM-1301SRJ(Z)</b> 30MFD, 370VAC	3A2005-03	1	1					
11	Start Capacitor	<b>KM-1301SAJ</b> 145-174MFD, 250VAC	3A0076-01	1	1					
		<b>KM-1301SWJ</b> <b>KM-1301SRJ(Z)</b> 145-174MFD, 220VAC	3A0076-11	1	1					
12	Fan Motor Capacitor	<b>KM-1301SAJ</b> 5MFD, 250VAC	443192-02	1	-					
			4A6435-02		1					
13	Wire Harness A (includes item 14 and 15)		1A5695-01		1					

Title: C. Control Box Assembly Model: KM-1301S_J(Z)/3												
Index No.	Description	Material or Model Number	Part Number	Required Number								
				G-0 to N-3 (J)	N-3 (K) to P-4							
14	Fuse	AGC-10A, 250VAC	4A0893-07	1	1							
15	Fuse Holder		4A5443-01	1	-							
	In-Line Fuse Holder		4A6950-01		1							
16	Wire Harness B	<b>KM-1301SRJZ/3</b> <b>KM-1301SAJ/3</b> <b>KM-1301SWJ/3</b>	1A7316-01		1							
17	Wire Harness C	<b>KM-1301SRJZ/3</b>	1A5697-01		1							
18	Wire Harness D (not shown)	<b>KM-1301S_J(Z)/3</b>	1A5760-01		1							



## D. Accessories & Labels

### KM-1301S\_J(Z)/3

G-0 to P-4

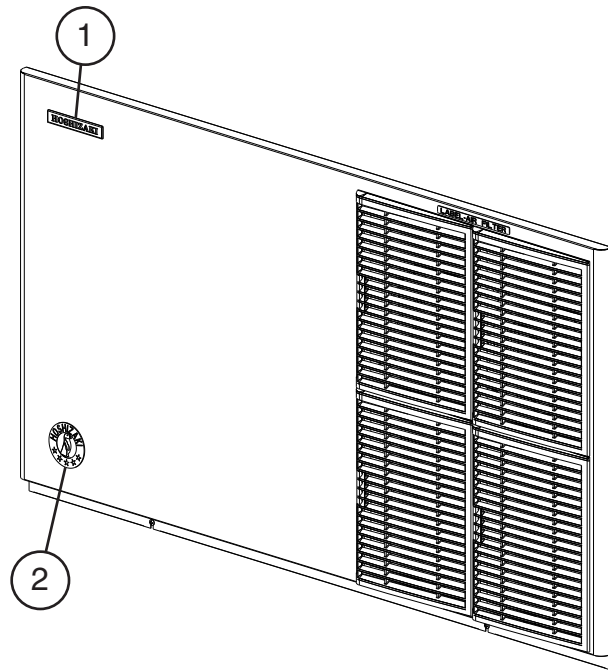

Title: D. Accessories & Labels Model: KM-1301S_J(Z)/3											
Index No.	Description	Material or Model Number	Part Number	Required Number							
				G-0 to P-4							
1	Hoshizaki Emblem Label		4A0560-01	1							
2	Penguin Label		475552L02	1							
3	Universal Brace		4A0363-01	2							
3a	Hex Bolt	5x12, SS	7B02-0512	4							