

NO. 71138
ISSUED: DEC. 9, 1998
REVISED: OCT. 22, 2001



**HOSHIZAKI
MODULAR FLAKER**

MODEL

F-1000MAF(-C)

F-1000MWF(-C)

F-1000MRF(-C)

F-1000MLF(-C)

PARTS LIST

F-1000MAF	H-0	MARCH, 1998
	J-0	DEC., 1998
	K-0	DEC., 1999
F-1000MAF-C	H-0	AUG., 1998
	J-0	DEC., 1998
	K-0	DEC., 1999
F-1000MWF	H-0	MARCH, 1998
	J-0	FEB., 1999
	K-0	JAN., 2000
	K-1	JUNE, 2000
F-1000MWF-C	H-0	AUG., 1998
	J-0	APRIL, 1999
	K-0	JAN., 2000
	K-1	JUNE, 2000
F-1000MRF	H-0	MARCH, 1998
	J-0	MARCH, 1999
	K-0	DEC., 1999
	K-1	JUNE, 2000
F-1000MRF-C	H-0	NOV., 1998
	J-0	MARCH, 1999
	K-0	DEC., 1999
F-1000MLF	H-0	MARCH, 1998
	J-0	FEB., 1999
	K-0	JAN., 2000
	K-1	JUNE, 2000
F-1000MLF-C	J-0	

MATERIAL ABBREVIATIONS

ALUMINUM

AL = Aluminum

COPPER

CU = Copper

PLASTIC

ABS = Acrylonitrile -butadiene - styrene
 AC = Polyacetal
 EVA = Ethylene vinyl acetate
 PA = Polyamide = Nylon
 PC = Polycarbonate
 PE = Polyethylene
 PES = Polyester
 PETP = Polyethylene terephthalate = Tetlon
 PP = Polypropylene
 PS = Polystyrene
 PIFE = Polytetrafluoroethylene = Teflon
 PUR = Polyurethane
 PVC = Polyvinyl chloride

RUBBER

VN = Vinyl Nitrile
 EPDM = EP rubber
 NBR = Nitrile butadiene rubber
 NR = Natural rubber
 NP = Neoprene
 SIR = Silicone rubber
 SYR = Synthetic rubber
 EPH = Epichlorohydrin

STEEL

GS = Galvanized steel
 SS = Stainless steel
 PS = Plated steel
 PAS = Primed steel

AUXILIARY CODE

Ex.1

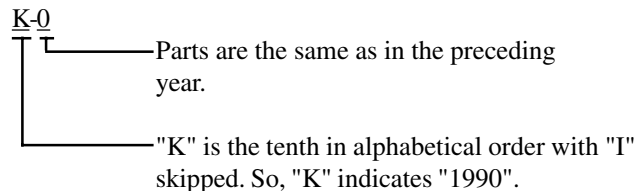

(Note) - = Part deleted.

x = Part deleted and replaced by "o" part.

o = New part for "x" in the same auxiliary code.

Ex.2

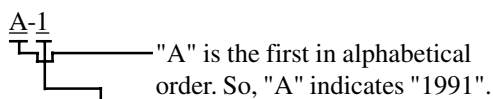

Ex.3

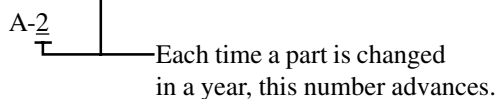

FASTENER ABBREVIATION LIST

ST	Phillips Truss Machine Screw
SP	Phillips Pan Head Machine Screw
SF	Phillips Flat Head Machine Screw
SS	Phillips Pan Head Machine Screw with Split Lock Washer
SW	Phillips Pan Head Machine Screw with Split Lock Washer and Flat Washer
T1	Phillips Truss Head Tapping Screw (Correspond to Type A)
T2	Phillips Truss Head Tapping Screw (Correspond to Type B)
T3	Phillips Truss Head Tapping Screw (Correspond to Type C)
FT	Phillips Truss Head Tapping Screw (Special)
BH	Hexagon Head Bolt
BC	Socket Head Cap Screw
BS	Hexagon Bolt with Split Washer
BW	Hexagon Bolt with Split Washer and Flat Washer
BF	Hexagon Flange Bolt
BR	Cross-Recessed Hexagon Head Bolt
BRW	Cross-Recessed Hexagon Head Bolt with Split Lock Washer and Flat Washer
WL	Split Lock Washer
WT	External Tooth Washer
WF	Flat Washer
WS	Spring Washer
NH	Hexagon Nut
NF	Hexagon Flange Nut
NC	Hexagon Cap Nut
NS	Square Nut
NW	Wing Nut

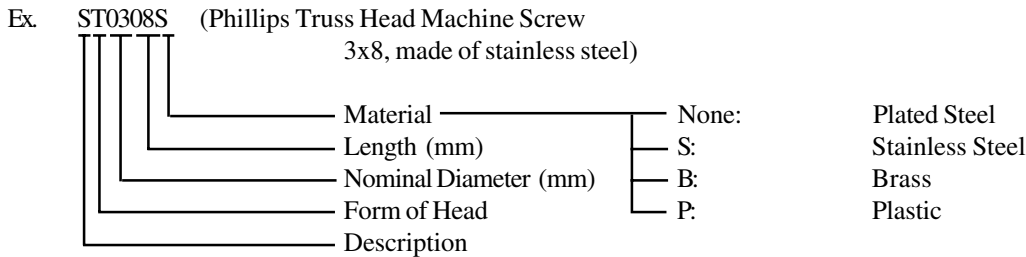

(Note) Second character is numerical except toe list.

Ex. S1, S2, B3 etc.

And abbreviations and names are shown under the illustration.

MODEL: F-1000MAF/-C				TITLE: A. ICE FLAKER ASSEMBLY				
INDEX NO.	DESCRIPTION	MATERIAL OR MODEL NUMBER	PART NUMBER	REQUIRED NUMBER				
				H-0	J-0	K-0		
1	CHASSIS	G.S	2A1176G01	1	1	1		
2	REAR PANEL	G.S	2A1008G01	1	1	1		
3	JUNCTION BOX COVER	G.S	433410-01	1	1	1		
4	SIDE FRAME (R)	G.S	2A1047G01	1	1	1		
5	FRONT FRAME	G.S	3A0324G01	1	1	1		
6	BRACKET-RESERVOIR	G.S	2A1060-01	1	1	1		
7	DRAIN PAN	ABS	323765G02	1	1	1		
8	STRAP	G.S	4A1474-01	1	1	1		
9	TAPPING SCREW - BLACK	STEEL,4X8	433954-01	2	2	2		
10	CLAMP	WS75-75-C	4A0337-12	3	3	3		
11	BUSHING	SB-562-7	420470-09	1	1	1		
12	RING	PA	432661-02	1	1	1		
13	"O" RING	G70	7616-G070	1	1	1		
14	PACKING-SPOUT	EPDM	321037-01	1	1	1		
15	SPOUT	PC	104797-01	1	1	1		
16	THUMBSCREW	S.S,ABS	415949G04	3	3	3		
17	STRAP	S.S	321038G02	1	1	1		
18	STRAP	S.S	328703-02	1	1	1		
19	BUSHING	SB-1500-21	420470-06	3	3	3		
20	BARRIER	G.S	4A0688-01	1	1	1		
21	BUSHING	SR-30-1	420472-03	2	2	2		
22	WIRE SADDLE	LWS-2NS	4A0338-02	5	5	5		
23	WIRE SADDLE	LWS-4NS	4A0338-04	4	4	4		
24	SCREW-GROUNDING	BRASS	433304-02	1	1	1		
25	SIDE PANEL (RIGHT)	S.S	2A0324G01	1	1	1		
26	SIDE PANEL (LEFT)	S.S	2A1014G02	1	1	1		
27	TOP PANEL	S.S	2A1051-02	1	1	1		
28	FRONT PANEL	S.S	3A0325-01	1	1	1		
29	LOUVER (B)	P.P	103121-03	2	2	2		
30	AIR FILTER (B)	-	208283G03	2	2	2		
31	CABLE TIE	CV-150	7920-0003	1	1	1		

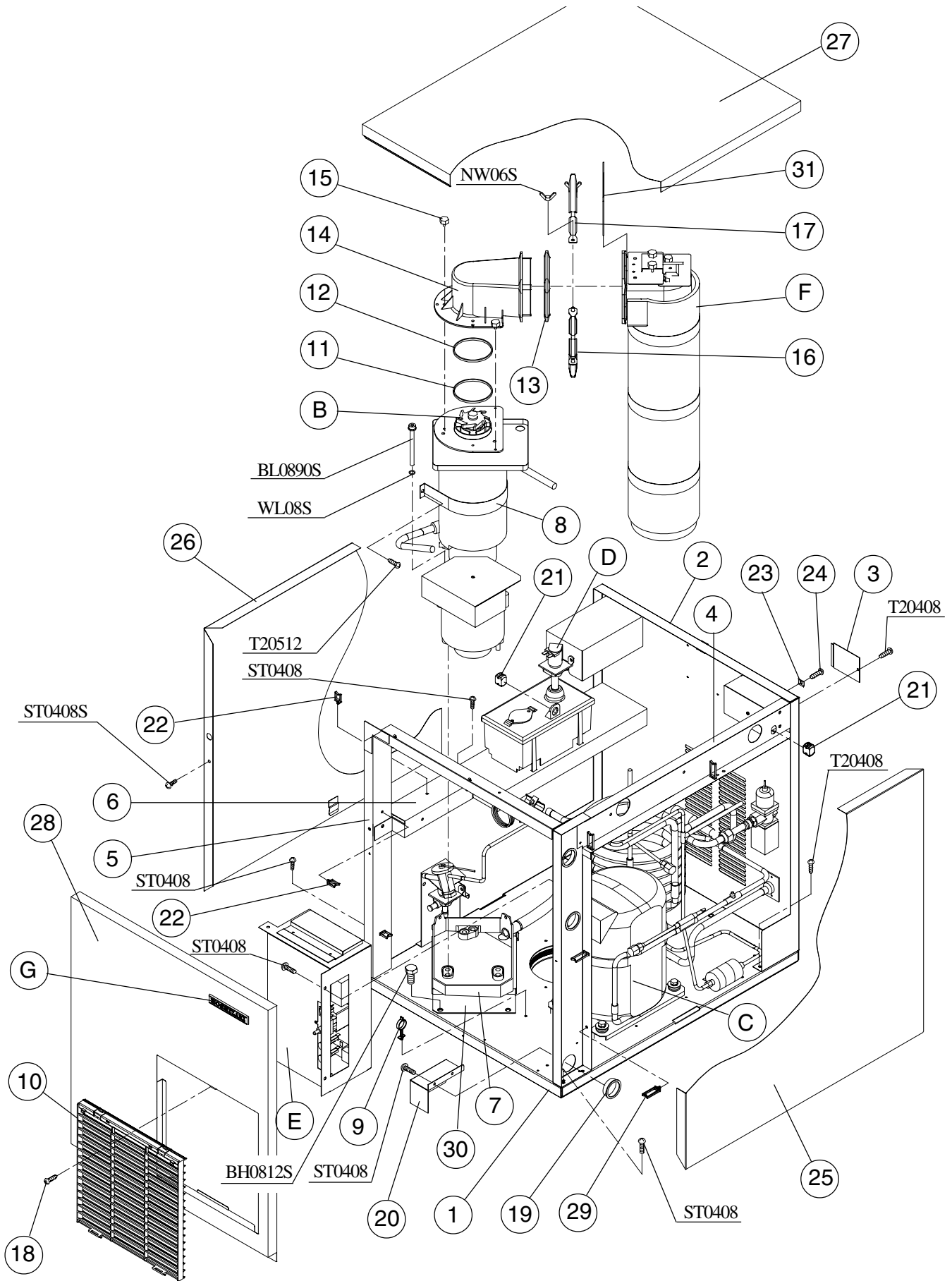

MODEL: F-1000MWF/-C		TITLE: A. ICE FLAKER ASSEMBLY						
INDEX NO.	DESCRIPTION	MATERIAL OR MODEL NUMBER	PART NUMBER	REQUIRED NUMBER				
				H-0	J-0	K-0	K-1	
1	CHASSIS	G.S	2A1176G01	1	1	1	1	
2	REAR PANEL	G.S	2A1008G01	1	1	1	1	
3	JUNCTION BOX COVER	G.S	433410-01	1	1	1	1	
4	SIDE FRAME (R)	G.S	2A1047G01	1	1	1	1	
5	FRONT FRAME	G.S	3A0324G01	1	1	1	1	
6	BRACKET-RESERVOIR	G.S	2A1059-01	1	1	1	1	
7	DRAIN PAN	ABS	323765G02	1	1	1	1	
8	STRAP	G.S	4A1474-01	1	1	1	1	
9	CLAMP	WS75-75-C	4A0337-12	3	3	3	3	
10	LOUVER (B)	P.P	103121-03	2	2	2	2	
11	RING	PA	432661-02	1	1	1	1	
12	"O" RING	G70	7616-G070	1	1	1	1	
13	PACKING-SPOUT	EPDM	321037-01	1	1	1	1	
14	SPOUT	PC	104797-01	1	1	1	1	
15	THUMBSCREW	S.S,ABS	415949G04	3	3	3	3	
16	STRAP	S.S	321038G02	1	1	1	1	
17	STRAP	S.S	328703-02	1	1	1	1	
18	TAPPING SCREW - BLACK	STEEL, 4 x 8	433954-01	1	1	1	1	
19	BUSHING	SB-1500-21	420470-06	3	3	3	3	
20	BARRIER	G.S	4A0688-01	1	1	1	1	
21	BUSHING	SR-30-1	420472-03	2	2	2	2	
22	WIRE SADDLE	VWS42105-C	4A0338-02	5	5	5	5	
23	SQUARE WASHER	BRASS	433537-02	1	1	1	1	
24	SCREW-GROUNDING	BRASS	433304-02	1	1	1	1	
25	SIDE PANEL (RIGHT)	S.S	2A0324G01	1	1	1	1	
26	SIDE PANEL (LEFT)	S.S	2A1014G01	1	1	1	1	
27	TOP PANEL	S.S	2A1051-02	1	1	1	1	
28	FRONT PANEL	S.S	3A0325-01	1	1	1	1	
29	WIRE SADDLE	VWS42105-C	4A0338-04	4	4	4	4	
30	BRACKET - GEAR MOTOR	G.S	3A0396G01	1	1	1	1	
31	BRACKET-CHUTE	S.S	4A1712-01	1	1	1	1	

MODEL: F-1000MRF/-C				TITLE: A. ICE FLAKER ASSEMBLY				
INDEX NO.	DESCRIPTION	MATERIAL OR MODEL NUMBER	PART NUMBER	REQUIRED NUMBER				
				H-0	J-0	K-0	K-1	
1	CHASSIS	G.S	2A1176G02	1	1	1	1	
2	REAR PANEL	G.S	2A1010G01	1	1	1	1	
3	JUNCTION BOX COVER	G.S	433410-01	2	2	2	2	
4	SIDE FRAME (R)	G.S	2A1047G01	1	1	1	1	
5	FRONT FRAME	G.S	3A0324G01	1	1	1	1	
6	BRACKET-RESERVOIR	G.S	2A1059-01	1	1	1	1	
7	DRAIN PAN	ABS	323765G02	1	1	1	1	
8	STRAP	G.S	4A1474-01	1	1	1	1	
9	CLAMP	WS75-75-C	4A0337-12	5	5	5	5	
10	LOUVER (B)	P.P	103121-03	1	1	1	1	
11	RING	PA	432661-02	1	1	1	1	
12	""O""RING"	G70	7616-G070	1	1	1	1	
13	PACKING-SPOUT	EPDM	321037-01	1	1	1	1	
14	SPOUT	PC	104797-01	1	1	1	1	
15	THUMBSCREW	S.S,ABS	415949G04	3	3	3	3	
16	STRAP	S.S	321038G02	1	1	1	1	
17	STRAP	S.S	328703-02	1	1	1	1	
18	TAPPING SCREW - BLACK	STEEL, 4 x 8	433954-01	1	1	1	1	
19	BUSHING	SB-1500-21	420470-06	3	3	3	3	
20	BARRIER	G.S	4A0688-01	1	1	1	1	
21	BUSHING	SR-30-1	420472-03	3	3	3	3	
22	WIRE SADDLE	VWS42105-C	4A0338-02	5	5	5	5	
23	SQUARE WASHER	BRASS	433537-02	2	2	2	2	
24	SCREW-GROUNDING	BRASS	433304-02	2	2	2	2	
25	SIDE PANEL (RIGHT)	S.S	2A0324G01	1	1	1	1	
26	SIDE PANEL (LEFT)	S.S	2A1014G01	1	1	1	1	
27	TOP PANEL	S.S	2A1051-02	1	1	1	1	
28	FRONT PANEL	S.S	3A0325-01	1	1	1	1	
29	WIRE SADDLE	VWS42105-C	4A0338-04	4	4	4	4	
30	BRACKET - GEAR MOTOR	G.S	3A0396G01	1	1	1	1	
31	BRACKET-CHUTE	S.S	4A1712-01	1	1	1	1	

MODEL: F-1000MLF/-C		TITLE: A. ICE FLAKER ASSEMBLY						
INDEX NO.	DESCRIPTION	MATERIAL OR MODEL NUMBER	PART NUMBER	REQUIRED NUMBER				
				H-0	J-0	K-0	K-1	
1	CHASSIS	G.S	2A1176G03	1	1	1	1	
2	REAR PANEL	G.S	2A1119G01	1	1	1	1	
3	JUNCTION BOX COVER	G.S	433410-01	1	1	1	1	
4	SIDE FRAME (R)	G.S	2A1047G01	1	1	1	1	
5	FRONT FRAME	G.S	3A0324G01	1	1	1	1	
6	BRACKET-RESERVOIR	G.S	2A1059-01	1	1	1	1	
7	DRAIN PAN	G.S	323765G02	1	1	1	1	
8	STRAP	G.S	4A1474-01	1	1	1	1	
9	CLAMP	WS75-75-C	4A0337-12	4	4	4	4	
10	LOUVER (B)	P.P	103121-01	1	1	1	1	
11	RING	PA	432661-02	1	1	1	1	
12	""O""RING"	G70	7616-G070	1	1	1	1	
13	PACKING-SPOUT	EPDM	321037-01	1	1	1	1	
14	SPOUT	PC	104797-01	1	1	1	1	
15	THUMBSCREW	S.S,ABS	415949G04	3	3	3	3	
16	STRAP	S.S	321038G02	1	1	1	1	
17	STRAP	S.S	328703-02	1	1	1	1	
18	TAPPING SCREW - BLACK	STEEL, 4 x 8	433954-01	1	1	1	1	
19	BUSHING	SB-1500-21	420470-06	3	3	3	3	
20	BARRIER	G.S	4A0688-01	1	1	1	1	
21	BUSHING	SR-30-1	420472-03	2	2	2	2	
22	WIRE SADDLE	VWS42105-C	4A0338-02	5	5	5	5	
23	SQUARE WASHER	BRASS	433537-02	1	1	1	1	
24	SCREW-GROUNDING	BRASS	433304-02	1	1	1	1	
25	SIDE PANEL (RIGHT)	S.S	2A0324G01	1	1	1	1	
26	SIDE PANEL (LEFT)	S.S	2A1014G01	1	1	1	1	
27	TOP PANEL	S.S	2A1051-02	1	1	1	1	
28	FRONT PANEL	S.S	3A0325-01	1	1	1	1	
29	WIRE SADDLE	VWS42105-C	4A0338-04	4	4	4	4	
30	BRACKET - GEAR MOTOR	G.S	3A0396G01	1	1	1	1	
31	BRACKET-CHUTE	S.S	4A1712-01	1	1	1	1	

MODEL: F-100MAF, MWF, MRF, MLF TITLE: B. ICE MAKING UNIT								
INDEX NO.	DESCRIPTION	MATERIAL OR MODEL NUMBER	PART NUMBER	REQUIRED NUMBER				
				H-0	J-0	K-0	K-1	
1	GEAR MOTOR	V06695-ACAA	4A1296-01	1	1	x1		
		-	4A2194-01			o1	1	
2	BARRIER - GEAR MOTOR	G.S	3A1037-01	1	1	1	1	
3	COUPLING - SPLINE	S.S	4A1297-01	1	1	1	1	
4	HOUSING	BRASS	2A0947G01	1	1	1	1	
5	"O" RING	G65	7616-G065	1	1	1	1	
6	MECHANICAL SEAL	HK9A-MN	432492-01	1	1	1	1	
7	AUGER	S.S	2A0932G02	1	1	1	1	
8	EVAPORATOR	-	2A1227G01	1	1	1	1	
9	EXTRUDING HEAD / 70F	S.S	327097G01	1	1	1	1	
10	SOCKET HEAD CAP SCREW	S.S, M10 x 15	429121-01	4	4	4	4	
11	WASHER	S.S	427184-01	4	4	4	4	
12	CUTTER	S.S	317071-02	1	x1			
		SS	3A1395-02		o1	1	1	
13	DOWEL PIN	S.S, 4 x 16	713S-0416	1	1	1	1	

HA

F-1000MAF-C, MWF-C, MRF-C, MLF-C

B. ICE MAKING UNIT

H-0, J-0, K-0, K-1

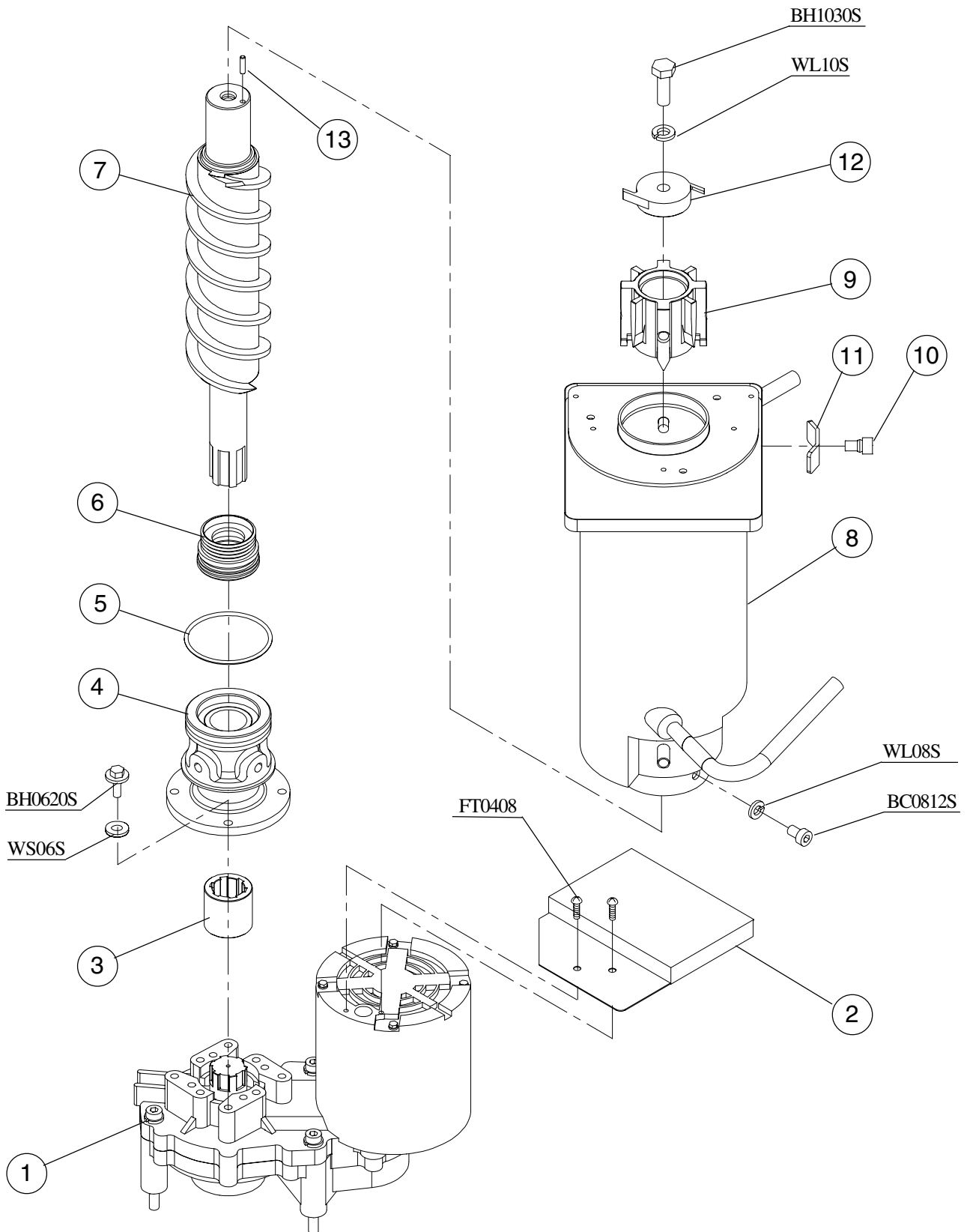

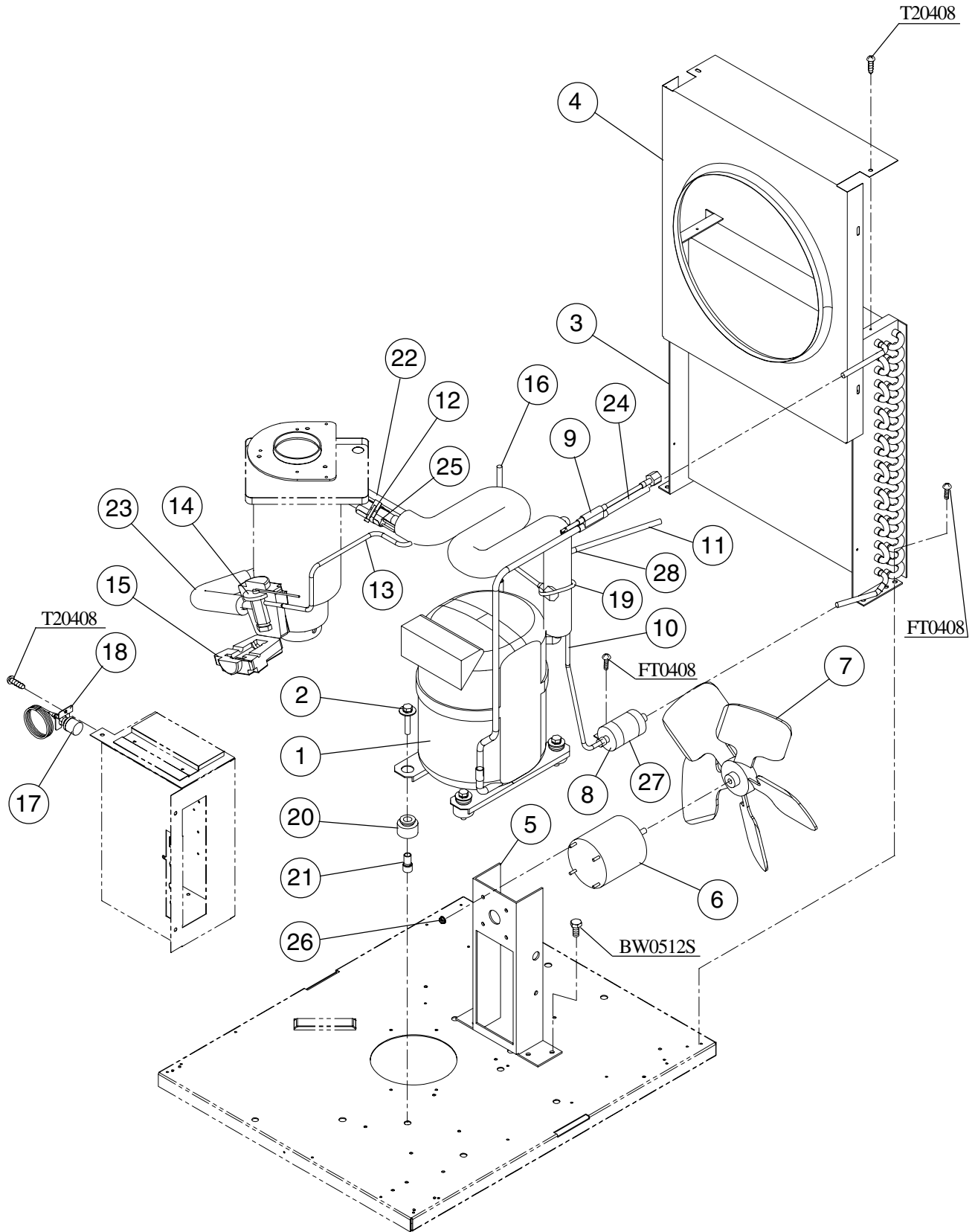

MODEL: F-1000MAF/-C TITLE: C. REFRIGERATION UNIT								
INDEX NO.	DESCRIPTION	MATERIAL OR MODEL NUMBER	PART NUMBER	REQUIRED NUMBER				
				H-0	J-0	K-0		
1	COMPRESSOR	RS70-CIE-PFV	4A1322-01	1	1	1		
2	BOLT	8 x 45	437889-01	4	4	4		
3	CONDENSER-AIR COOLED	967307C	211663-02	1	1	1		
4	SHROUD	G.S	2A0449-01	1	1	1		
5	FAN MOTOR BRACKET	G.S	3A0341-01	1	1	1		
6	FAN MOTOR	U90B17190-1031	440911-01	1	1	1		
7	FAN BLADE	AD12CW25	4A0197-01	1	1	1		
8	DRIER	ATCH-032S	4A1113-01	1	1	1		
9	COPPER TUBE (A) - HIGH SIDE	COPPER	3A0928G01	1	1	1		
10	COPPER TUBE (B) -HIGH SIDE	COPPER	3A0921-01	1	1	1		
11	COPPER TUBE-PROCESS	COPPER	4A1365-01	1	1	1		
12	CLAMP	08	443461-01	1	1	1		
13	COPPER TUBE - HEAT EXCHANGER	COPPER	3A0894G01	1	1	1		
14	EXPANSION VALVE	AN-1-SC	4A1117-01	1	1	1		
15	EXP. VALVE COVER	PE FOAM	4A1168-01	1	1	1		
16	COPPER TUBE-ACCESS VALVE	COPPER	4A1364G01	2	2	2		
17	PRESSURE SWITCH	ACB-2UB04	433441-05	1	1	1		
18	PRESSURE SWITCH BRACKET	G.S	434938-01	1	1	1		
19	CABLE TIE	CV-150	7920-0003	10	10	10		
20	GROMMET	027-0073-00	434403-01	4	4	4		
21	SPACER	027-0072-02	434404-01	4	4	4		
22	INSULATION TUBE	L=130	7762-2943	1	1	1		
23	INSULATION TUBE	L=170	7762-1330	1	1	1		
24	INSULATION TUBE	L=30	7762-0717	1	1	1		
25	HOLDER/EXP.VALVE-1/2	S.S	3A0112-01	1	1	1		
26	SELF- LOCKING NUT	NO-8-32	7N2110832	4	4	4		
27	DRIER BRACKET	G.S	445847-01	1	1	1		
28	TEE	111-2	436000-01	1	1	1		

MODEL: F-1000MWF/C TITLE: C. REFRIGERATION UNIT								
INDEX NO.	DESCRIPTION	MATERIAL OR MODEL NUMBER	PART NUMBER	REQUIRED NUMBER				
				H-0	J-0	K-0	K-1	
1	COMPRESSOR	R570CIE-PFV	4A1322-01	1	1	1	1	
2	CONDENSER-WATER COOLED	(S-0725)	215545G01	1	1	1	1	
3	WATER REGULATOR	V46EA-7	4A0911-04	1	1	1	1	
4	-	-	-					
5	DRIER	ATCH-032S	4A1113-01	1	1	1	1	
6	COPPER TUBE (A) - HIGH SIDE	COPPER	3A0920G01	1	1	1	1	
7	COPPER TUBE (B) - HIGH SIDE	COPPER	3A0921-01	1	1	1	1	
8	COPPER TUBE - ACCESS VALVE	COPPER	4A1364G01	1	1	1	1	
9	CLAMP	08	443461-01	1	1	1	1	
10	COPPER TUBE - HEAT EXCHANGER	COPPER	3A0894G01	1	1	1	1	
11	EXPANSION VALVE	AN-1-SC	4A1117-01	1	1	1	1	
12	DRIER BRACKET	G.S	445847-01	1	1	1	1	
13	COPPER TUBE-DRIER	COPPER	3A0891-01	1	1	1	1	
14	COPPER TUBE-PROCESS	COPPER	4A1365-01	1	1	1	1	
15	EXP. VALVE COVER	PE FOAM	4A1168-01	1	1	1	1	
16	PRESSURE SWITCH	ACB-2UB04	433441-05	1	1	1	1	
17	PRESS. SWITCH BRACKET	G.S	434938-01	1	1	1	1	
18	COPPER TUBE-WATER INLET	COPPER	3A1095G01	1	1	1	1	
19	COPPER TUBE-WATER OUTLET	COPPER	3A0930G01	1	1	1	1	
20	CABLE TIE	CV-150	7920-0003	14	14	14	14	
21	GROMMET	027-0073-00	434403-01	4	4	4	4	
22	SPACER	027-0072-02	434404-01	4	4	4	4	
23	BOLT	8 x 45	437889-01	1	1	1	1	
24	INSULATION TUBE	L=130	7762-2943	1	1	1	1	
25	INSULATION TUBE	L=170	7762-1330	1	1	1	1	
26	INSULATION TUBE	L=30	7762-0717	1	1	1	1	
27	HOLDER/EXP. VALVE-1/2	S.S	3A0112-01	1	1	1	1	
28	WASHER	-	4A0655-03	3	3	3	3	
29	TEE	111-2	436000-01	1	1	1	1	
30	MALE CONNECTOR	48F-8-6	4A1087-01	1	1	1	1	

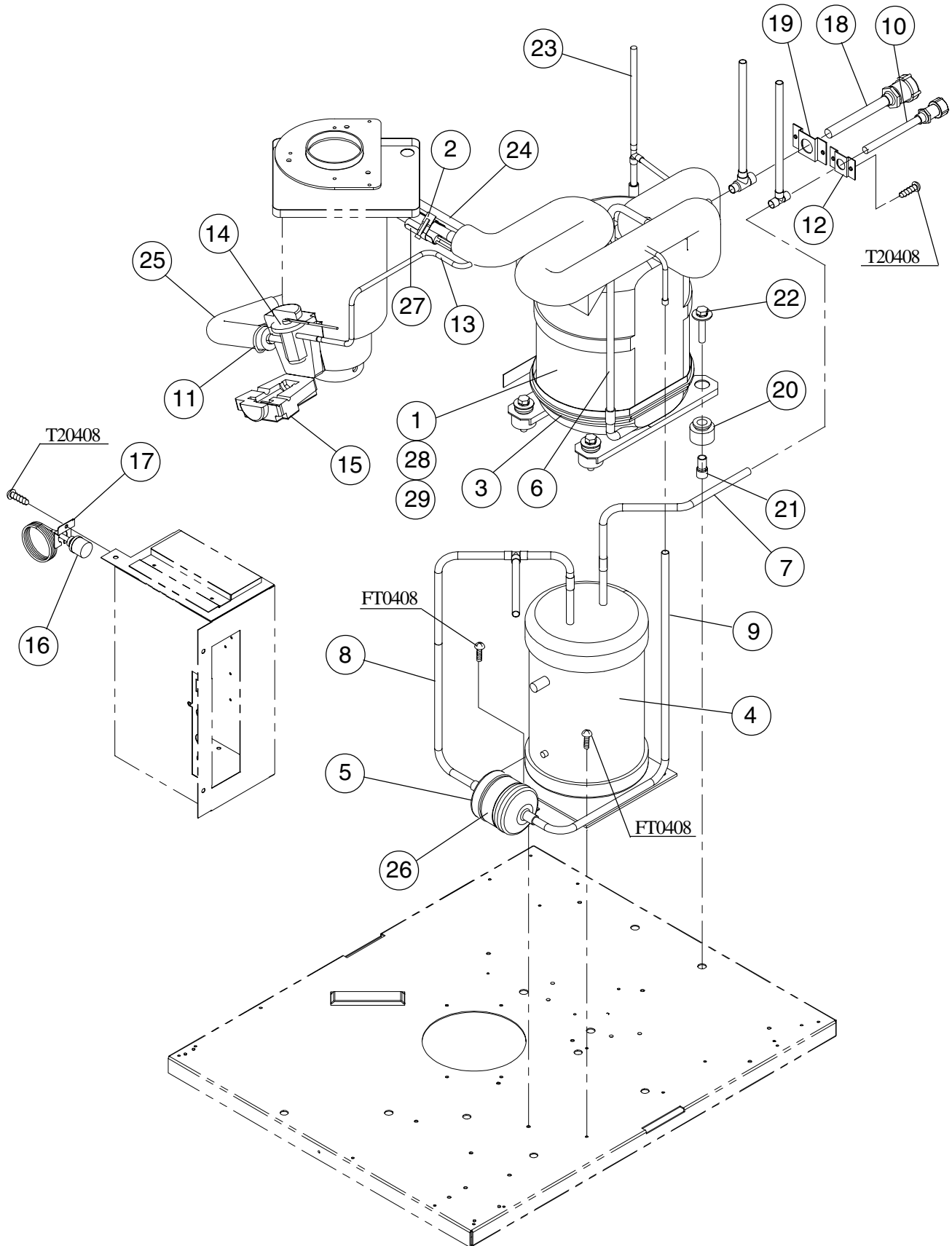

MODEL: F-1000MRF/C TITLE: C. REFRIGERATION UNIT								
INDEX NO.	DESCRIPTION	MATERIAL OR MODEL NUMBER	PART NUMBER	REQUIRED NUMBER				
				H-0	J-0	K-0	K-1	
1	COMPRESSOR	RS70CIE-PFV	4A1322-01	1	1	1	1	
2	CLAMP	08	443461-01	1	1	1	1	
3	CRANKCASE HEATER	018-0038-0045W,120V	434186-01	1	1	1	1	
4	RECEIVER TANK	6813	437652-01	1	1	1	1	
5	DRIER	ATCH-053S	4A1338-01	1	1	1	1	
6	COPPER TUBE(A)- HIGH SIDE	COPPER	3A0923G01	1	1	1	1	
7	COPPER TUBE (B) - HIGH SIDE	COPPER	3A0924G01	1	1	1	1	
8	COPPER TUBE(C)- HIGH SIDE	COPPER	3A1222G01	1	1	1	1	
9	COPPER TUBE(D)- HIGH SIDE	COPPER	4A1368-01	1	1	1	1	
10	COUPLING	COPPER	433751G01	1	1	1	1	
11	CABLE TIE	CV-150	7920-0003	9	9	9	9	
12	TUBE HOLDER - S	G.S.	438246-01	1	1	1	1	
13	COPPER TUBE - HEAT EXCHANGER	COPPER	3A0927G01	1	1	1	1	
14	EXPANSION VALVE	AN-1-SC	4A1117-01	1	1	1	1	
15	EXP. VALVE COVER	PE FOAM	4A1168-01	1	1	1	1	
16	PRESSURE SWITCH	ACB-2UB04	433441-05	1	1	1	1	
17	PRESSURE SWITCH BRACKET	G.S.	434938-01	1	1	1	1	
18	COUPLING (MALE)	BRASS	434132G01	1	1	1	1	
19	TUBE HOLDER-L	G.S.	438245-01	1	1	1	1	
20	GROMMET	027-0073-00	434403-01	4	4	4	4	
21	SPACER	027-0072-02	434404-01	4	4	4	4	
22	BOLT	8 x 45	437889-01	4	4	4	4	
23	COPPER TUBE - ACCESS VALVE	COPPER	4A1364G01	1	1	1	1	
24	INSULATION TUBE	L=130	7762-2943	1	1	1	1	
25	INSULATION TUBE	L=170	7762-1330	1	1	1	1	
26	DRIER BRACKET	G.S	4A1348-01	1	1	1	1	
27	HOLDER/EXP.VALVE-1/2	S.S	3A0112-01	1	1	1	1	
28	TERMINAL COVER	-	4A1322F01	1	1	1	1	
29	SPRING CLIP	-	4A1322F02	1	1	1	1	

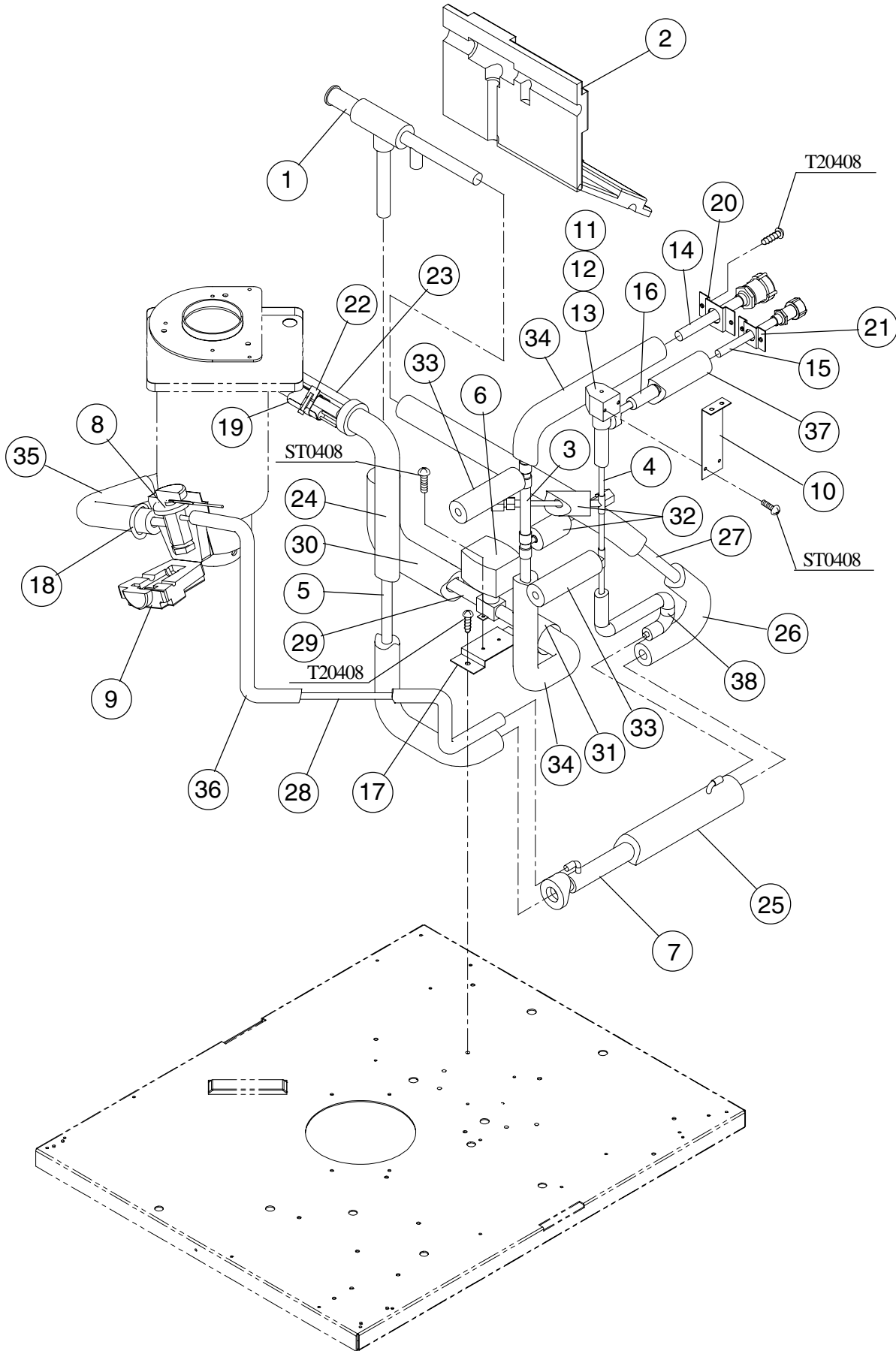

MODEL: F-1000MLF-C TITLE: C. REFRIGERATION UNIT								
INDEX NO.	DESCRIPTION	MATERIAL OR MODEL NUMBER	PART NUMBER	REQUIRED NUMBER				
				H-0	J-0	K-0	K-1	
1	EPR VALVE		4A1384-01	1	1	1	1	
2	EPR VALVE COVER	PE - FOAM	340434-01	1	1	1	1	
3	COPPER TUBE - (OUT)	COPPER	3A0951G01	1	1	1	1	
4	COPPER TUBE - (IN)	COPPER	3A0953G01	1	1	1	1	
5	COPPER TUBE-HEAT EXCHANGER	COPPER	3A0956-01	1	1	1	1	
6	SOLENOID VALVE	SLHE 1/2	446873-01	1	1	1	1	
7	HEAT EXCHANGER		4A1374-01	1	1	1	1	
8	EXPANSION VALVE	AN-1-SC	4A1117-01	1	1	1	1	
9	EXPANSION VALVE COVER	PE FOAM	4A1168-01	1	1	1	1	
10	HOT GAS VALVE BRACKET	G.S.	4A1400-01	1	1	1	1	
11	VALVE BODY	70	440352-01	1	1	1	1	
12	COIL - VALVE	ABS-25-1-HD-2	440353-01	1	1	1	1	
13	BOLT		440353F01	1	1	1	1	
14	COUPLING-(MALE)	COPPER	434132G01	1	1	1	1	
15	COUPLING	COPPER	433751G01	1	1	1	1	
16	STRAINER	625007	4A1385-01	1	1	1	1	
17	BRACKET (B) VALVE	G.S.	446871-01	1	1	1	1	
18	CABLE TIE	CV-150	7920-0003	23	35	35	35	
19	HOLDER / EXP. VALVE - 1/2	S.S.	3A0112-01	1	1	1	1	
20	TUBE HOLDER - L	G.S.	438245-01	1	1	1	1	
21	TUBE HOLDER - S	G.S.	438246-01	1	1	1	1	
22	CLAMP	08	443461-01	1	1	1	1	
23	INSULATION TUBE	L=130	7762-2943	1	1	1	1	
24	INSULATION TUBE	L=850	7762-1330	1	1	1	1	
25	INSULATION TUBE	L=310	7762-2040	1	1	1	1	
26	INSULATION TUBE	L=600	7762-1330	1	1	1	1	
27	COPPER TUBE - VALVE	COPPER	3A0955-01	1	1	1	1	
28	COPPER TUBE - EXP. VALVE	COPPER	3A0957-01	1	1	1	1	
29	COPPER TUBE - EPR	COPPER	3A0954-01	1	1	1	1	
30	INSULATION TUBE	L=250	7762-2040		1	1	1	

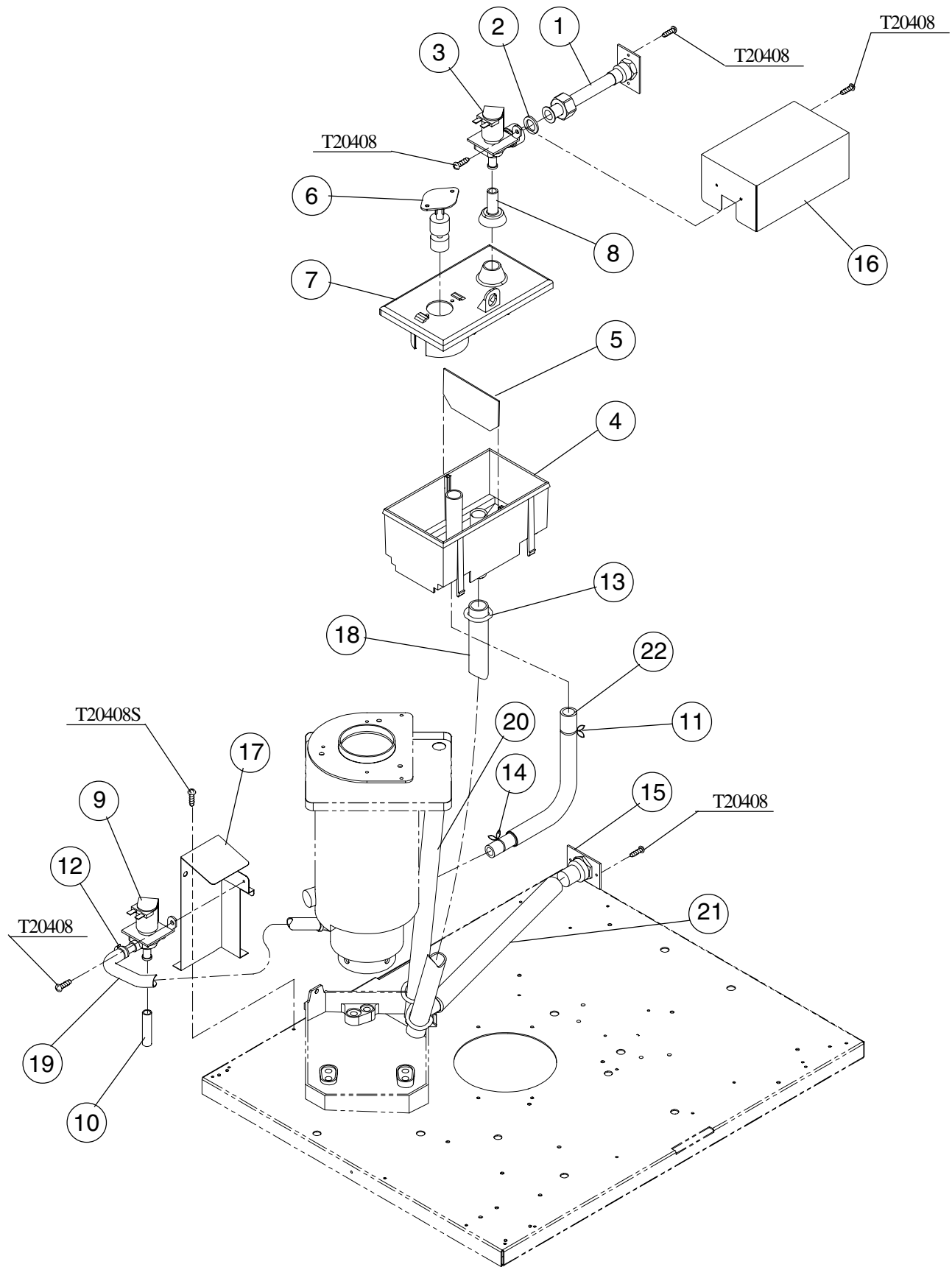

HA

F-1000MAF(-C), MWF(-C), MRF(-C), MLF(-C)

D. WATER CIRCUIT

J-0, K-0, K-1

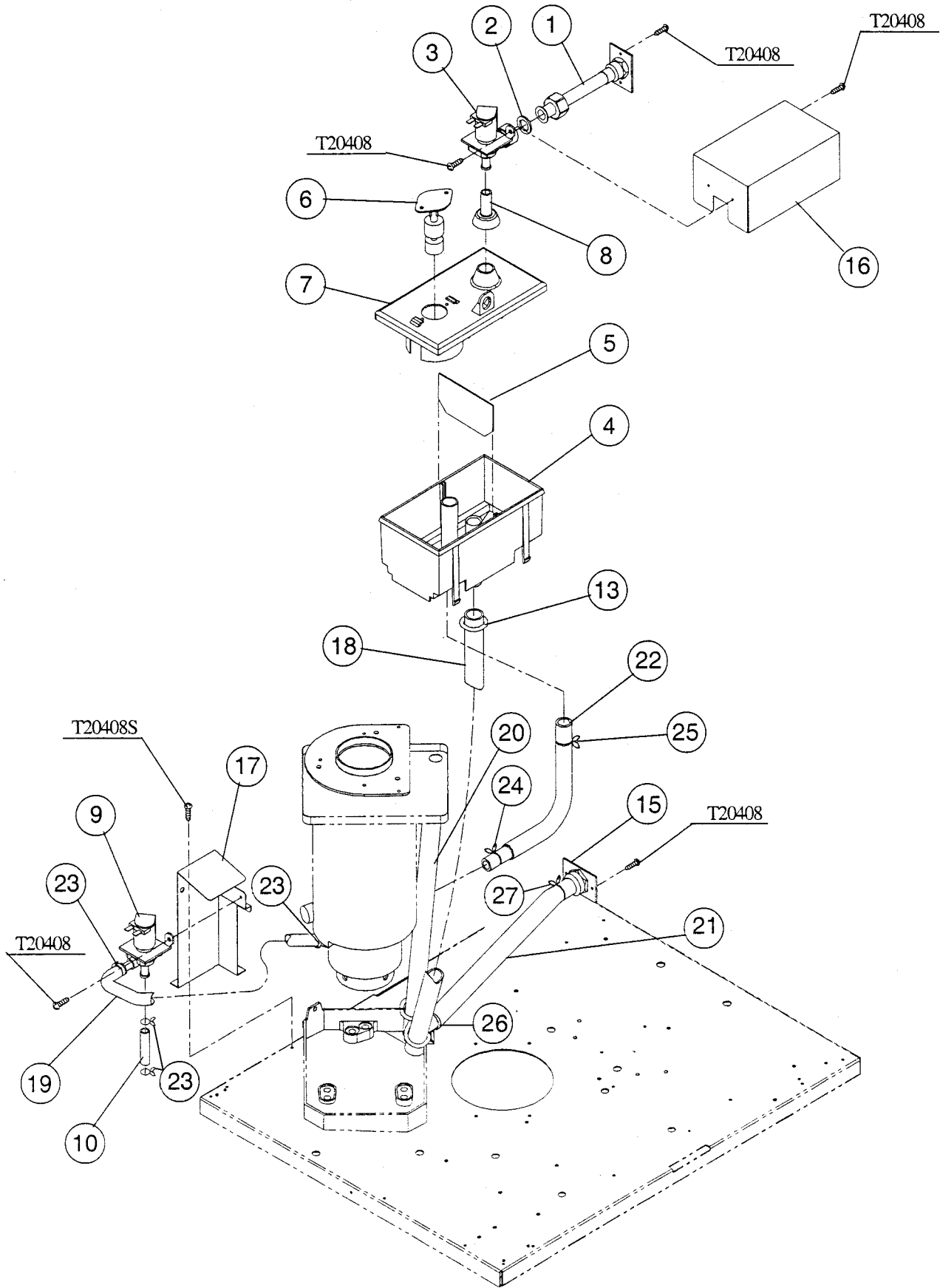

MODEL: F-1000MAF(-C), MWF(-C), MRF(-C), MLF(-C) TITLE: D. WATER CIRCUIT								
INDEX NO.	DESCRIPTION	MATERIAL OR MODEL NUMBER	PART NUMBER	REQUIRED NUMBER				
				H-0	J-0	K-0	K-1	
1	WATER SUPPLY PIPE	COPPER	4A0891G01	1	1	1	1	
2	WASHER	K-59963	4A0867-01	1	1	1	1	
3	WATER VALVE	S-30	4A0865-01	1	1	1	1	
4	RESERVOIR	P.P.	2A0753-01	1	1	1	1	
5	SEPARATOR-RESERVOIR	ABS	4A1255-01	1	1	1	1	
6	FLOAT SWITCH	TW-1221-101	435490-01	1	1	1	1	
7	RESERVOIR COVER	P.P.	214810-01	1	1	1	1	
8	INLET- RESERVOIR	SI.R.	4A0869-01	1	1	1	1	
9	WATER VALVE	S-60N	4A0866-01	1	1	x1		
		-	4A2077-01			o1	1	
10	VINYL HOSE	L=50	7725-0912	1	1	x1		
		L=40	7716-0913			o1	1	
11	CLAMP	SK-18.3	435934-06	1	-			
12	CLAMP	MH-30N	421642-04	2	-			
13	CABLE TIE	CV-150	7920-0003	8	4	4	4	
14	CLAMP	SK-17	435934-05	1	1	1	1	
15	FITTING	COPPER	4A0776G01	1	1	1	1	
16	WATER VALVE BRACKET	G.S	3A0553-01	1	1	1	1	
17	WATER VALVE BRACKET (D)	G.S	3A0554-01	1	1	1	1	
18	SILICONE HOSE	L=410	7730-1822	1	1	1	1	
19	SILICONE HOSE	L=225	7730-0912	1	1	x1		
		L=225	7730I3896			o1	1	
20	VINYL HOSE	L=430	7725-1923	1	1	1	1	
21	VINYL HOSE	L=390	7716-2025	1	1	1	1	
22	RESERVOIR HOSE	EPDM	4A1165-01	1	1	1	1	
23	HOSE CLAMP	-	4A2017-04		4	x4		
		-	4A2017-08			o4	4	
24	HOSE CLAMP	-	4A2017-05		1	1	1	
25	HOSE CLAMP	-	4A2017-06		1	1	1	
26	HOSE CLAMP	-	4A2017-01		1	1	1	
27	HOSE CLAMP	-	4A2017-02		1	1	1	

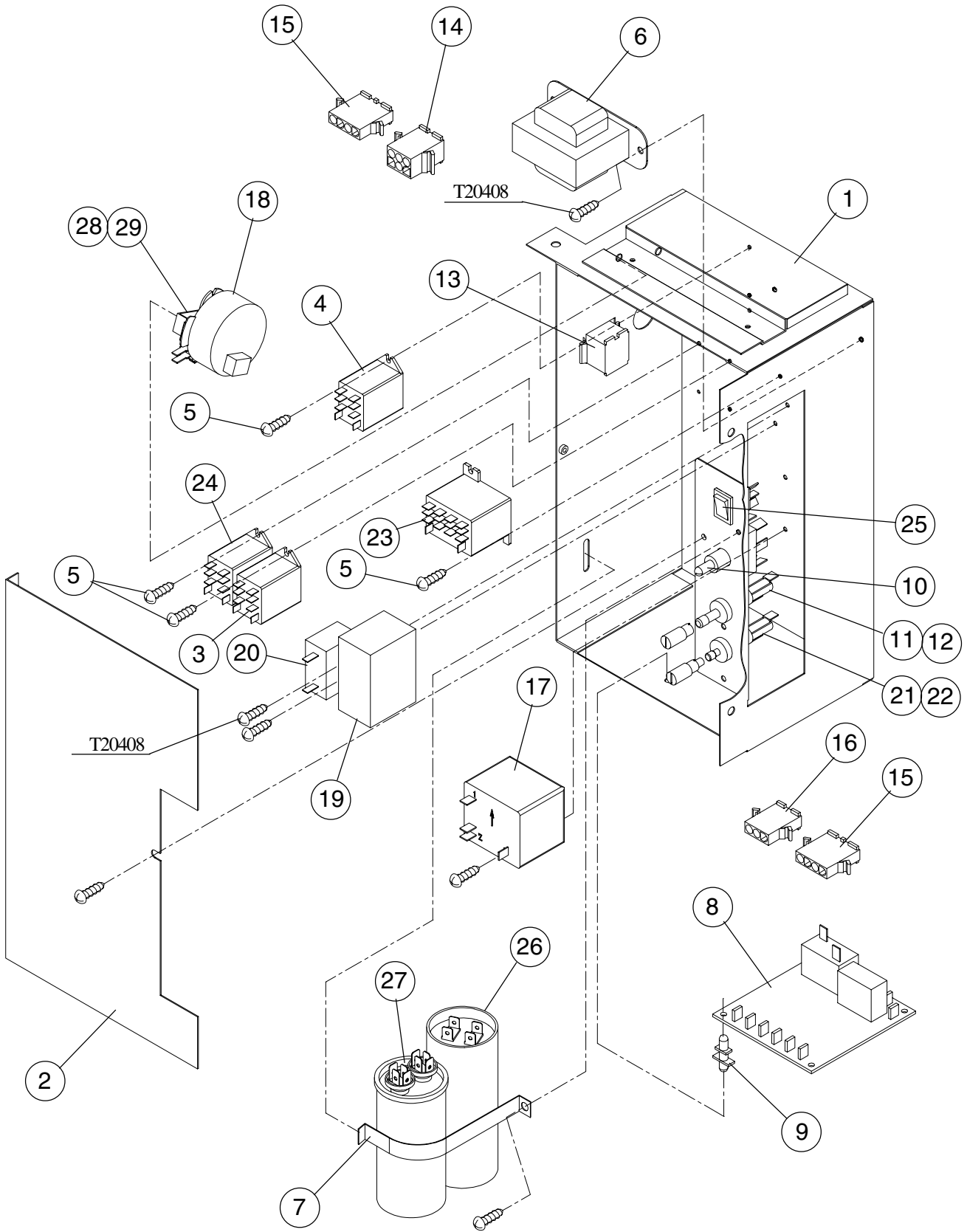

MODEL: F-1000MAF(-C) TITLE: E. CONTROL BOX ASSEMBLY								
INDEX NO.	DESCRIPTION	MATERIAL OR MODEL NUMBER	PART NUMBER	REQUIRED NUMBER				
				H-0	J-0	K-0		
1	CONTROL BOX	G.S	2A0229G04	1	1	1		
2	COVER-CONTROL BOX	G.S	3A0411-01	1	1	1		
3	RELAY	LY-1F, AC120V	418271-03	1	1	1		
4	RELAY	LY-2F, AC24V	406132-03	1	1	1		
5	TAPPING SCREW	3 x 8	431415-01	8	8	8		
6	TRANSFORMER	BE1416225GEK 120/24V, 1A	4A0557-01	1	1	1		
7	STRAP	G.S	434580-07	1	1	1		
8	TIMER BOARD	H2AA144C01	437305-01	1	1	1		
9	BOARD SUPPORT	CBLS37-N	4A0336-03	4	4	4		
10	TOGGLE SWITCH	7599K1	4A0567-01	1	1	x1		
		-	4A2332-01			o1		
11	FUSE HOLDER	HTB921, 250V, 1A	4A0892-01	1	1	1		
12	FUSE	AGC-1, 250V, 1A	4A0893-01	1	1	1		
13	9P PLUG HOUSING	3191-09P	412832-02	1	1	1		
14	6P PLUG HOUSING	3191-06P	412832-03	1	1	1		
15	4P PLUG HOUSING	3191-04P	412832-05	2	2	2		
16	3P PLUG HOUSING	3191-03P	412832-06	1	1	1		
17	STARTER	3ARR3CT24S5	4A0875-01	1	1	x1		
		-	4A1107-13			o1		
18	TIMER	9816-2	4A0889-01	1	1	1		
19	CAPACITOR (GM)	12MFD, 330VAC	4A0894-01	1	1	1		
20	CAPACITOR (FM)	5MFD	443192-02	1	1	1		
21	FUSE	GMD1.5A	4A0893-04	1	1	1		
22	FUSE HOLDER	HTB92M	4A0892-02	1	1	1		
23	RELAY	LY-4F,AC24V	406133-04	1	1	1		
24	RELAY	LY1F-HSD, AC220/240V	418271-05	1	1	1		
25	ROCKER SWITCH	62111929-0-0-N	4A0558-01	1	1	1		
26	CAPACITOR - STARTING	3535B5A0108A250B8	3A0076-02	1	1	1		
27	CAPACITOR	X386S(HG02)	439943-02	1	1	1		

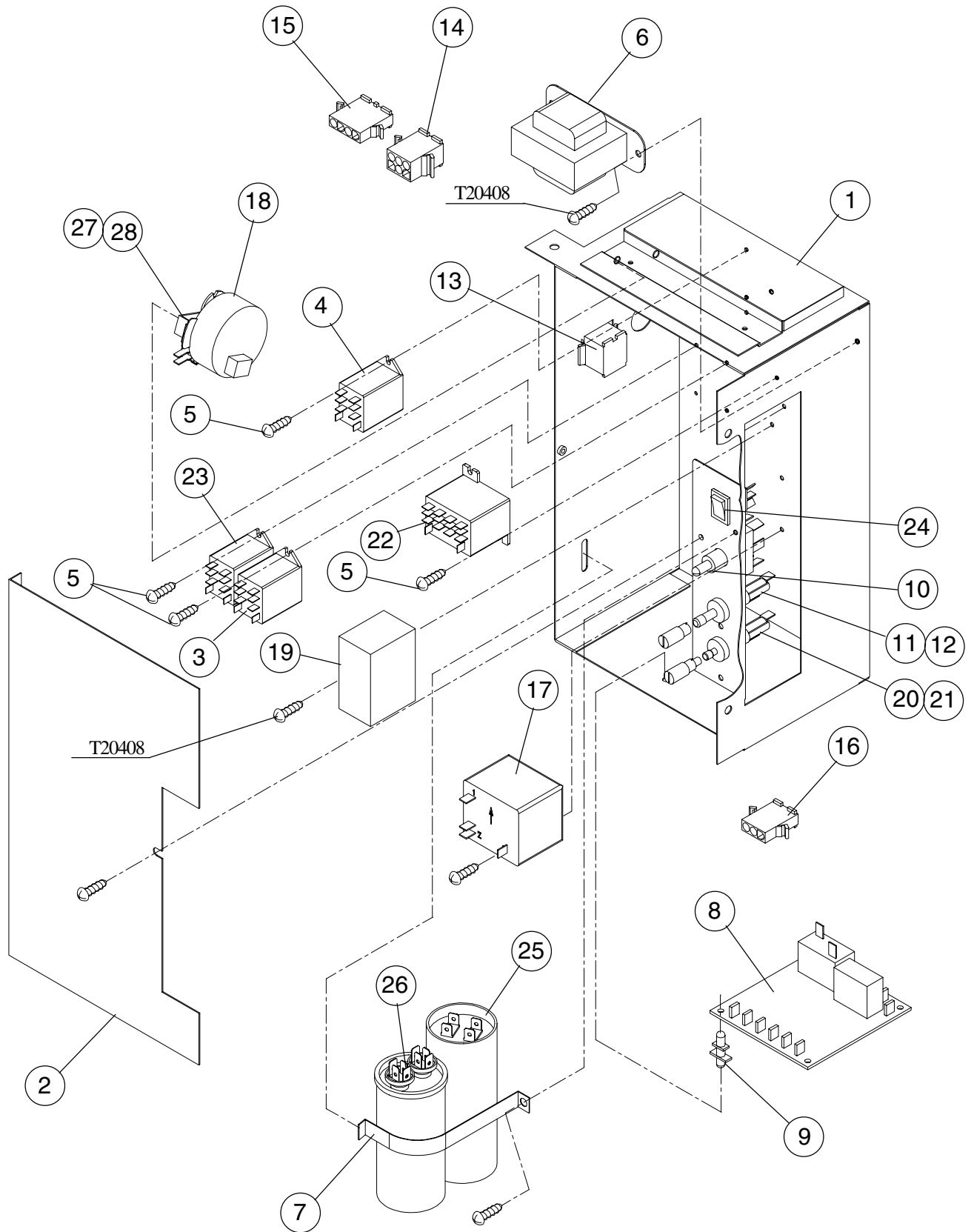

MODEL: F-1000MWF(-C), MRF(-C) TITLE: E. CONTROL BOX ASSEMBLY								
INDEX NO.	DESCRIPTION	MATERIAL OR MODEL NUMBER	PART NUMBER	REQUIRED NUMBER				
				H-0	J-0	K-0	K-1	
1	CONTROL BOX	G.S	2A0229G04	1	1	1	1	
2	COVER-CONTROL BOX	G.S	3A0411-01	1	1	1	1	
3	RELAY	LY-1F, AC120V	418271-03	1	1	1	1	
4	RELAY	LY-2F, AC24V	406132-03	1	1	1	1	
5	TAPPING SCREW	3 x 8	431415-01	8	8	8	8	
6	TRANSFORMER	BE1416225GEK 120/24V, 1A	4A0557-01	1	1	1	1	
7	STRAP	G.S	434580-07	1	1	1	1	
8	TIMER BOARD	H2AA144C01	437305-01	1	1	1	1	
9	BOARD SUPPORT	CBLS37-N	4A0336-03	4	4	4	4	
10	TOGGLE SWITCH	7599K1	4A0567-01	1	1	1	x1	
		-	4A2332-01				o1	
11	FUSE HOLDER	HTB921, 250V, 1A	4A0892-01	1	1	1	1	
12	FUSE	AGC-1, 250V, 1A	4A0893-01	1	1	1	1	
13	9P PLUG HOUSING	3191-09P	412832-02	1	1	1	1	
14	6P PLUG HOUSING	3191-06P	412832-03	1	1	1	1	
15	4P PLUG HOUSING	3191-04P	412832-05	2	2	2	2	
16	3P PLUG HOUSING	3191-03P	412832-06	1	1	1	1	
17	STARTER	3ARR3CT24S5	4A0875-01	1	1	1	x1	
		-	4A1107-13				o1	
18	TIMER	9816-2	4A0889-01	1	1	1	1	
19	CAPACITOR (GM)	12MFD, 330VAC	4A0894-01	1	1	1	1	
20	FUSE	GMD1.5A	4A0893-04	1	1	1	1	
21	FUSE HOLDER	HTB92M	4A0892-02	1	1	1	1	
22	RELAY	LY-4F,AC24V	406133-04	1	1	1	1	
23	RELAY	LY1F-HSD, AC220/240V	418271-05	1	1	1	1	
24	ROCKER SWITCH	62111929-0-0-N	4A0558-01	1	1	1	1	
25	CAPACITOR - STARTING	3535B5A0108A250B8	3A0076-02	1	1	1	1	
26	CAPACITOR	X386S(HG02)	439943-02	1	1	1	1	

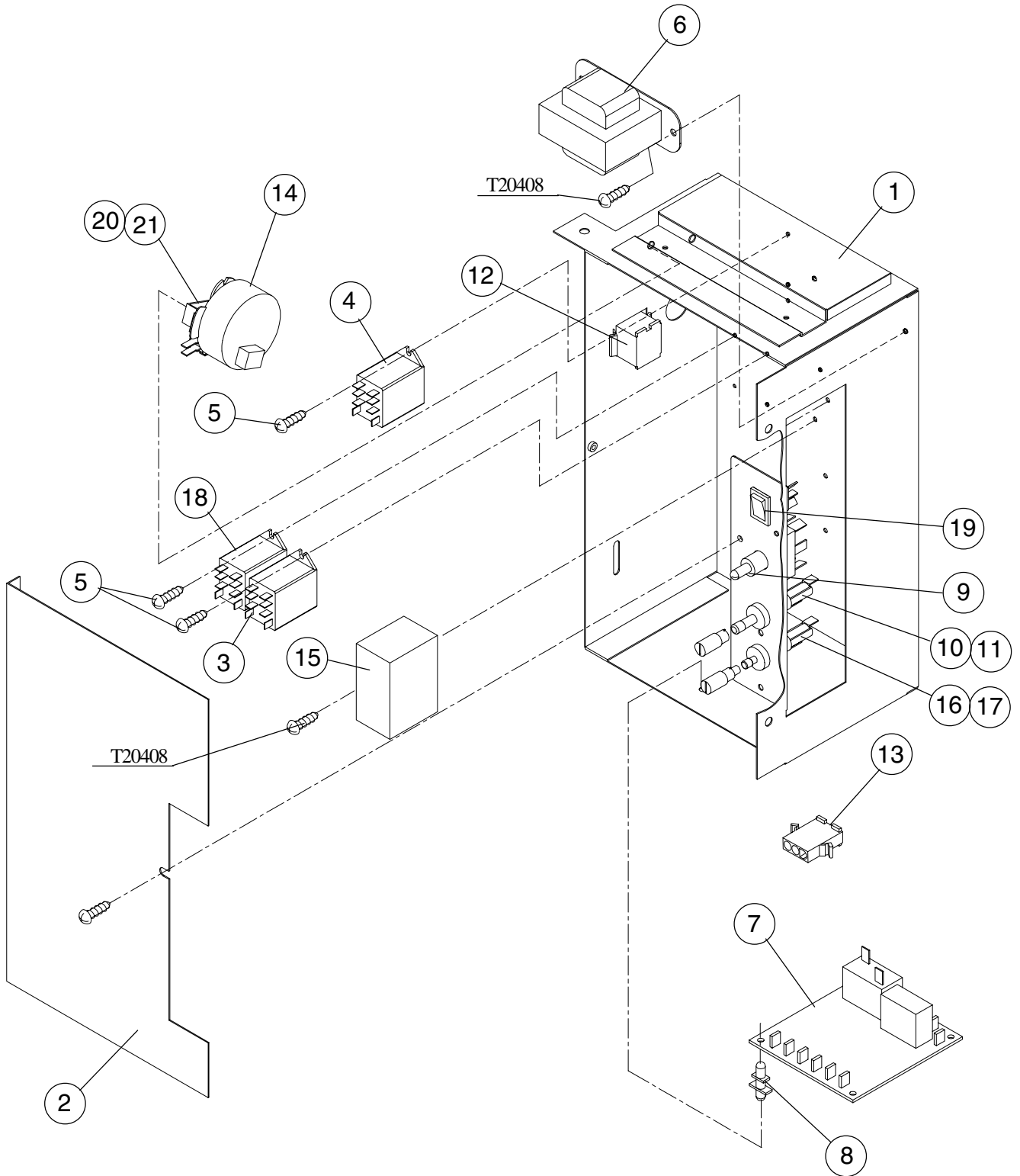

MODEL: F-100MLF(-C)		TITLE: E. CONTROL BOX ASSEMBLY						
INDEX NO.	DESCRIPTION	MATERIAL OR MODEL NUMBER	PART NUMBER	REQUIRED NUMBER				
				H-0	J-0	K-0	K-1	
1	CONTROL BOX	G.S	2A0229G04	1	1	1	1	
2	COVER-CONTROL BOX	G.S	3A0411-01	1	1	1	1	
3	RELAY	LY-2F, AC120V	406132-07	1	1	1	1	
4	RELAY	LY-2F, AC24V	406132-03	1	1	1	1	
5	TAPPING SCREW	3 x 8	431415-01	6	6	6	6	
6	TRANSFORMER	BE1416225GEK 120/24V, 1A	4A0557-01	1	1	1	1	
7	TIMER BOARD	H2AA144C01	437305-01	1	1	1	1	
8	BOARD SUPPORT	CBLS37-N	4A0336-03	4	4	4	4	
9	TOGGLE SWITCH	7599K1	4A0567-01	1	1	1	x1	
		-	4A2332-01				o1	
10	FUSE HOLDER	250V, 1A	4A0892-01	1	1	1	1	
11	FUSE	250V, 1A	4A0893-01	1	1	1	1	
12	9P PLUG HOUSING	3191-09P	412832-02	1	1	1	1	
13	3P PLUG HOUSING	3191-03P	412832-06	1	1	1	1	
14	TIMER	9816-2	4A0889-01	1	1	1	1	
15	CAPACITOR (GM)	12MFD, 330VAC	4A0894-01	1	1	1	1	
16	FUSE	GMD1.5A	4A0893-04	1	1	1	1	
17	FUSE HOLDER	HTB-92M	4A0892-02	1	1	1	1	
18	RELAY	LY1F-HSD, AC220/240V	418271-05	1	1	1	1	
19	ROCKER SWITCH	62111929-0-0-N	4A0558-01	1	1	1	1	
20	CONNECTOR	-	4A0899-02	1	1	1	1	
21	SCREW	32 x 3/8	4A0898-01	2	2	2	2	

HA

F-1000MAF(-C), MWF(-C), MRF(-C), MLF(-C) F. CHUTE ASSEMBLY H-0, J-0, K-0, K-1

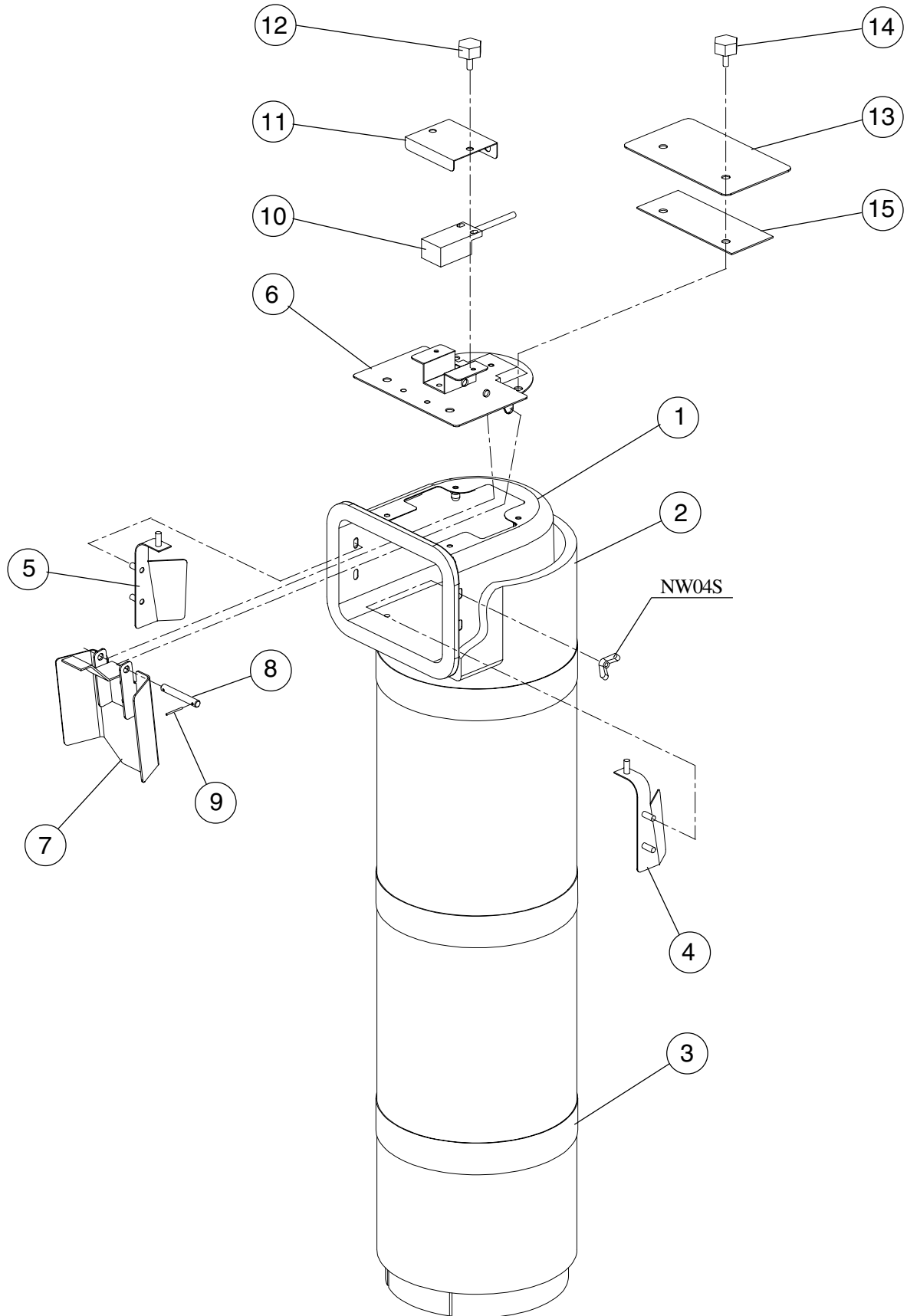

MODEL: F-100MAF(-C), MWF(-C), MRF(-C), MLF(-C) TITLE: F. CHUTE ASSEMBLY								
INDEX NO.	DESCRIPTION	MATERIAL OR MODEL NUMBER	PART NUMBER	REQUIRED NUMBER				
				H-0	J-0	K-0	K-1	
1	CHUTE	PE	2A1057-01	1	1	1	1	
2	INSULATION-CHUTE	PE FOAM	213304-02	1	1	1	1	
3	TIE	PA	436531G01	3	3	3	3	
4	BAFFLE-CHUTE (A)	S.S	3A0400G01	1	1	1	1	
5	BAFFLE-CHUTE (B)	S.S	3A0399G01	1	1	1	1	
6	BIN CONTROL	S.S	338043G02	1	1	1	-	
		S.S	3A1535G01				x1	
		S.S	3A1744G01				o1	
7	ACTUATOR	S.S	436848G01	1	1	1	1	
8	SHAFT	S.S	436851-01	1	1	1	1	
9	SNAP PIN	S.S,SSP-5	715S-0005	2	2	2	2	
10	PROXIMITY SWITCH	RS-601	427223-01	1	1	1	-	
		E00901	4A2033-01				1	
11	COVER-SWITCH	S.S	451870-01	1	1	1	1	
12	THUMBSCREW	ABS,S.S	415949G04	2	2	2	2	
13	PLATE	S.S	438336-01	1	1	1	-	
		S.S	4A2039-01				1	
14	THUMBSCREW	ABS,S.S	415949G09	2	2	2	2	
15	PACKING	EPDM	441217-01	1	1	1	1	

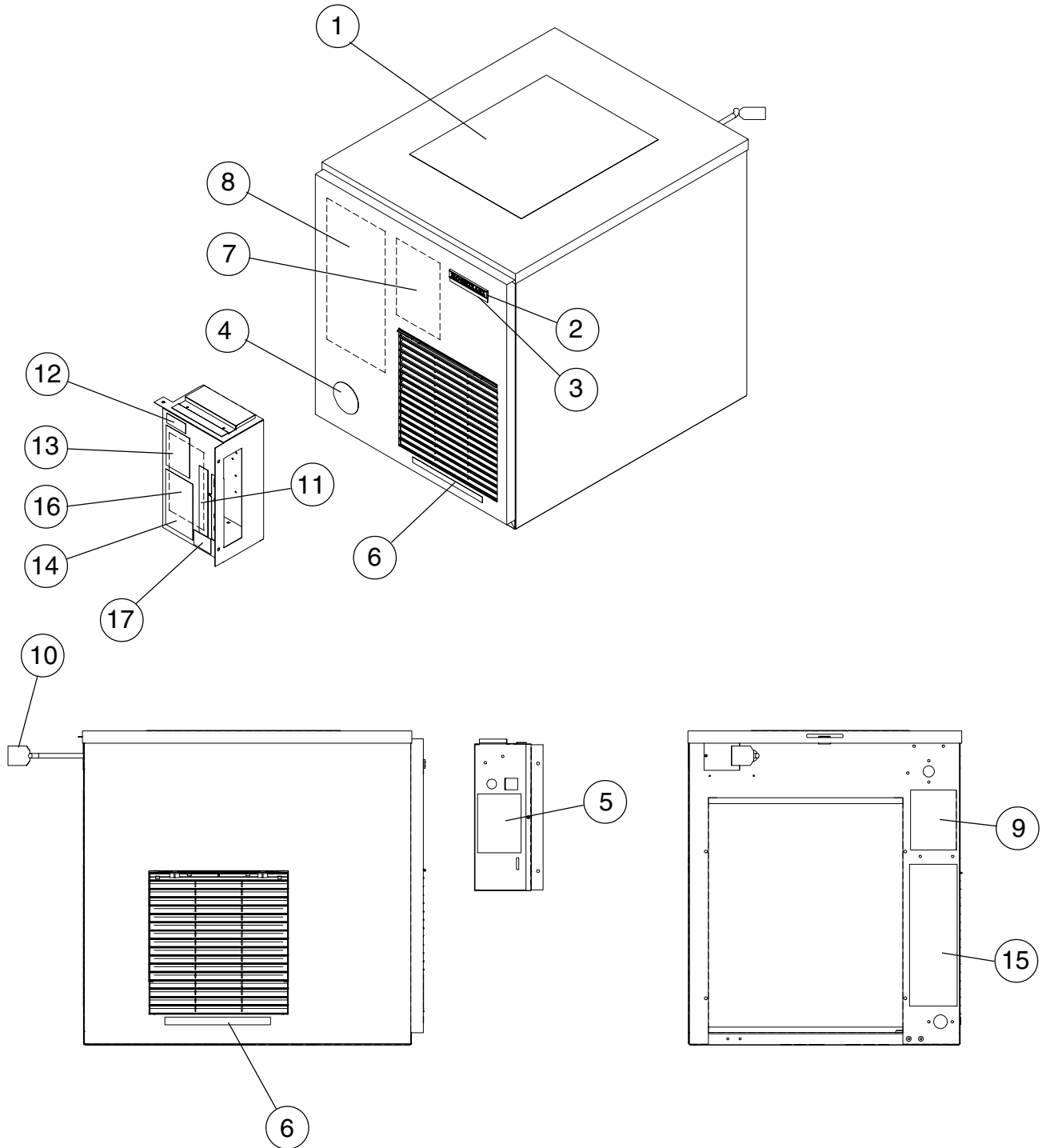

MODEL: F-100MAF				TITLE: G. LABEL LOCATION				
INDEX NO.	DESCRIPTION	MATERIAL OR MODEL NUMBER	PART NUMBER	REQUIRED NUMBER				
				H-0	J-0	K-0		
1	INSTRUCTION SHEET	PAPER	2A1054-01	1	1	1		
2	EMBLEM	PETP FILM	4A0560-01	1	1	1		
3	MODEL NUMBER LABEL	PETP FILM	4A1321-03	1	1	1		
4	LABEL-PENGUIN-HA-R	PETP FILM	4A0526-01	1	1	1		
5	RATING LABEL	PES FILM	3A1122-01	1	1	1		
6	LABEL-AIR FILTER	PETP FILM	426177-01	2	2	2		
7	INSTRUCTION LABEL	PVC FILM	326371-01	1	1	1		
8	LABEL-CLEANING	PVC FILM	326370-01	1	1	1		
9	NAMEPLATE	PES FILM	3A0970-01	1	1	1		
10	TAG-WARNING:ELECTRICAL CONNECTION	PAPER	428430-01	1	1	1		
11	CONTROL LABEL	PVC FILM	4A1613-01	1	1	1		
12	LABEL-R404A	PES FILM	4A0960-01	1	1	1		
13	CAUTION LABEL (E)	PVC FILM	439145-01	1	1	1		
14	WIRING LABEL	PVC FILM	2A1393-01	1	1	1		
15	INSTRUCTION SHEET	PAPER	433523-01	1	1	1		
16	CAUTION LABEL (H)	PVC FILM	439148-01	1	1	1		
17	LABEL (GM) - FUSE	PVC FILM	4A1614-01	1	1	1		

MODEL: F-100MAF-C		TITLE: G. LABEL LOCATION						
INDEX NO.	DESCRIPTION	MATERIAL OR MODEL NUMBER	PART NUMBER	REQUIRED NUMBER				
				H-0	J-0	K-0		
1	INSTRUCTION SHEET	PAPER	2A1054-01	1	1	1		
2	EMBLEM	PETP FILM	4A0560-01	1	1	1		
3	MODEL NUMBER LABEL	PETP FILM	4A1321-07	1	1	1		
4	LABEL-PENGUIN-HA-R	PETP FILM	4A0526-01	1	1	1		
5	RATING LABEL	PES FILM	3A1122-05	1	1	1		
6	LABEL-AIR FILTER	PETP FILM	426177-01	1	1	1		
7	INSTRUCTION LABEL	PVC FILM	326371-01	1	1	1		
8	LABEL-CLEANING	PVC FILM	326370-01	1	1	1		
9	NAMEPLATE	PES FILM	3A0970-05	1	1	1		
10	TAG-WARNING:ELECTRICAL CONNECTION	PAPER	428430-01	1	1	1		
11	CONTROL LABEL	PVC FILM	4A1613-01	1	1	1		
12	LABEL-R404A	PES FILM	4A0960-01	1	1	1		
13	CAUTION LABEL (E)	PVC FILM	439145-01	1	1	1		
14	WIRING LABEL	PVC FILM	2A1393-01	1	1	1		
15	INSTRUCTION SHEET	PAPER	433523-01	1	1	1		
16	CAUTION LABEL (H)	PVC FILM	439148-01	1	1	1		
17	LABEL (GM) - FUSE	PVC FILM	4A1614-01	1	1	1		

