



HOSHIZAKI

Parts List

Cubelet Icemaker/Dispenser

Models

DCM-751BAH(-OS)

DCM-751BWH(-OS)

DCM-752BAH(-OS)



hoshizakiamerica.com

Number: 71321
Issued: 7-18-2011
Revised: 9-21-2020

CONTENTS

Auxiliary Codes.....	3
Note About Ordering Parts	3
A. Ice Dispenser Assembly	4
B. Refrigeration Circuit.....	7
DCM-75_BAH(-OS).....	7
DCM-751BWH(-OS).....	9
C. Ice Making Unit	11
D. Water Circuit	13
E. Control Box Assembly.....	15
F. Shutter Assembly	17
G. Dispensing & Agitating Gear Motor Assemblies.....	20
H. Bin Assembly.....	22
J. Accessories & Labels.....	24

Auxiliary Codes

DCM-751BAH

A-0 March 2011
B-0 January 2012
C-0 January 2013
D-0 January 2014
D-1 May 2014
E-0 January 2015
F-0 January 2016
G-0 January 2017
G-1 April 2017
H-0 January 2018
J-0 January 2019
J-1 July 2019

DCM-751BWH

A-0 March 2011
B-0 March 2012
C-1 March 2013
D-0 February 2014
D-1 May 2014
E-0 January 2015
F-0 May 2016
G-1 November 2017
H-0 June 2018
J-0 February 2019
J-1 July 2019
K-0 March 2020

DCM-752BAH

K-0 March 2020
K-1 September 2020

DCM-752BAH-OS

K-0 March 2020
K-1 September 2020

DCM-751BAH-OS

B-0 January 2012
C-0 January 2013
D-0 January 2014
D-1 May 2014
E-0 January 2015
F-0 January 2016
G-0 January 2017
G-1 April 2017
H-0 January 2018
J-0 January 2019
J-1 July 2019

DCM-751BWH-OS

A-0 June 2011
B-0 March 2012
C-1 March 2013
D-0 February 2014
D-1 September 2014
E-0 January 2015
F-0 May 2016
G-0 January 2017
H-0 May 2018
K-0 January 2020

Auxiliary Code Breakdown

The auxiliary code is the first two characters in the serial number. The first character indicates the year. Years progress or regress in alphabetical order. The series runs from "A" through "V" and the letters "I" and "O" are skipped. The second character indicates significant part changes within a year. Base is "0" and this number advances for each change. In cases where there is a letter in parentheses, this designates the month. This is the last character in the serial number. The series runs from "(A)" through "(M)" and the letter "(I)" is skipped. This designation is only included when identifying a parts change within an auxiliary code.

Note About Ordering Parts

Most assemblies cannot be ordered as complete units; parts in the assemblies generally must be ordered separately.

A. Ice Dispenser Assembly
DCM-751B_H(-OS), 752BAH(-OS)
 A-0 to K-1

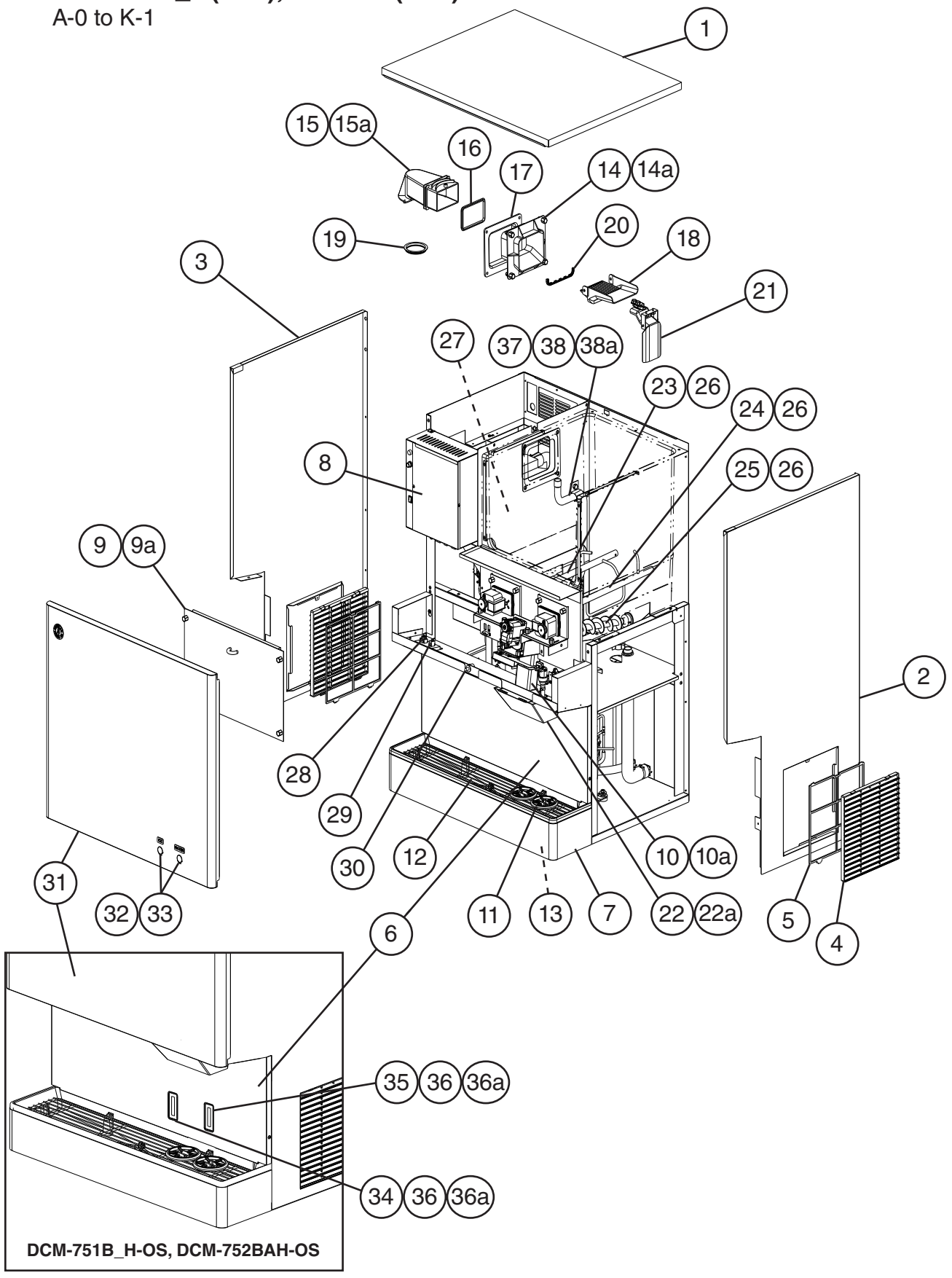

Title: A. Ice Dispenser Assembly Model: DCM-751B_H(-OS), DCM-752BAH(-OS)

Index No.	Description	Material or Model Number	Part Number	Required Number																	
				A-0 to E-0 (K)	E-0 (L) to K-1																
1	Top Panel		3A2526G01	1	1																
2	Right Side Panel	DCM-75_BAH(-OS)	2A6442-01	1	1																
		DCM-751BWH(-OS)	2A6442-02	1	1																
3	Left Side Panel	DCM-75_BAH(-OS)	2A6443-01	1	1																
		DCM-751BWH(-OS)	2A6443-02	1	1																
4	Louver	DCM-75_BAH(-OS)	103121-03	2	2																
5	Air Filter	DCM-75_BAH(-OS)	208283G03	2	2																
6	Apron Panel	DCM-751B_H	2A6495-01	1	1																
		DCM-752BAH																			
		DCM-751B_H-OS	3A6512G01	1	1																
7	Lower Panel		228436G01	1	1																
8	Control Box Cover		4A5054-01	1	1																
9	Storage Bin Cover		228433A01	1	1																
9a	Thumbscrew		415949G12	4	4																
10	Ice Chute		4A2204-01	1	1																
10a	Thumbscrew		415949G08	2	2																
11	Cup Guide		326702-01	2	2																
12	Grille		216100G01	1	1																
13	Drip Tray		2A2591G02	1	1																
14	Spout B		208807-01	1	1																
14a	Thumbscrew		415949G11	4	4																
15	Spout		103329G01	1	1																
15a	Thumbscrew		415949G11	3	3																
16	Spout Packing A		427195-01	1	1																
17	Spout Packing B		427196-01	1	1																
18	Guide		211171-01	1	1																
19	Packing		427151-02	1	1																
20	Packing		320668-01	1	1																
21	Actuator		208795G01	1	1																
22	Spout Cover		215773-01	1	1																
22a	Thumbscrew		415949G08	2	2																
23	Left Agitator		319017G02	1	1																
24	Right Agitator		321013G01	1	1																
25	Dispense Auger		339194G01	1	1																
26	Gasket		429758-01	3	3																
27	Drain Pan		323765G01	1	1																
28	Control Switch (rocker)		4A6179-01	1	1																
29	Dispense Switch (rocker)		4A0558-01	1	1																
30	Safety Switch (plunger)		4A5034-01	1	1																
31	Front Panel	DCM-751B_H DCM-752BAH	3A6515G01	1	-																
			3A8898G01		1																
		DCM-751B_H-OS DCM-752BAH-OS	2A6496-02	1	-																
			3A8902G02		1																
32	Push Switch Assembly (includes item 33)	DCM-751B_H DCM-752BAH	3A4997A01	1	1																
33	Push Switch	DCM-751B_H DCM-752BAH	435745-02	2	2																

Title: A. Ice Dispenser Assembly Model: DCM-751B_H(-OS), DCM-752BAH(-OS)											
Index No.	Description	Material or Model Number	Part Number	Required Number							
				A-0 to E-0 (K)	E-0 (L) to K-1						
34	Ice Sensor Assembly	DCM-751B_H-OS DCM-752BAH-OS	4A3753G01	1	1						
35	Water Sensor Assembly	DCM-751B_H-OS DCM-752BAH-OS	4A3753G02	1	1						
36	Sensor Latch	DCM-751B_H-OS DCM-752BAH-OS	4A3848-01	2	2						
36a	Thumbscrew		415949G10	2	2						
37	Drain Hose		320836-01	1	1						
38	Drain Hose Bracket		432496-01	1	1						
38a	Thumbscrew		415949G08	1	1						

B. Refrigeration Circuit
DCM-75_BAH(-OS)
A-0 to K-1

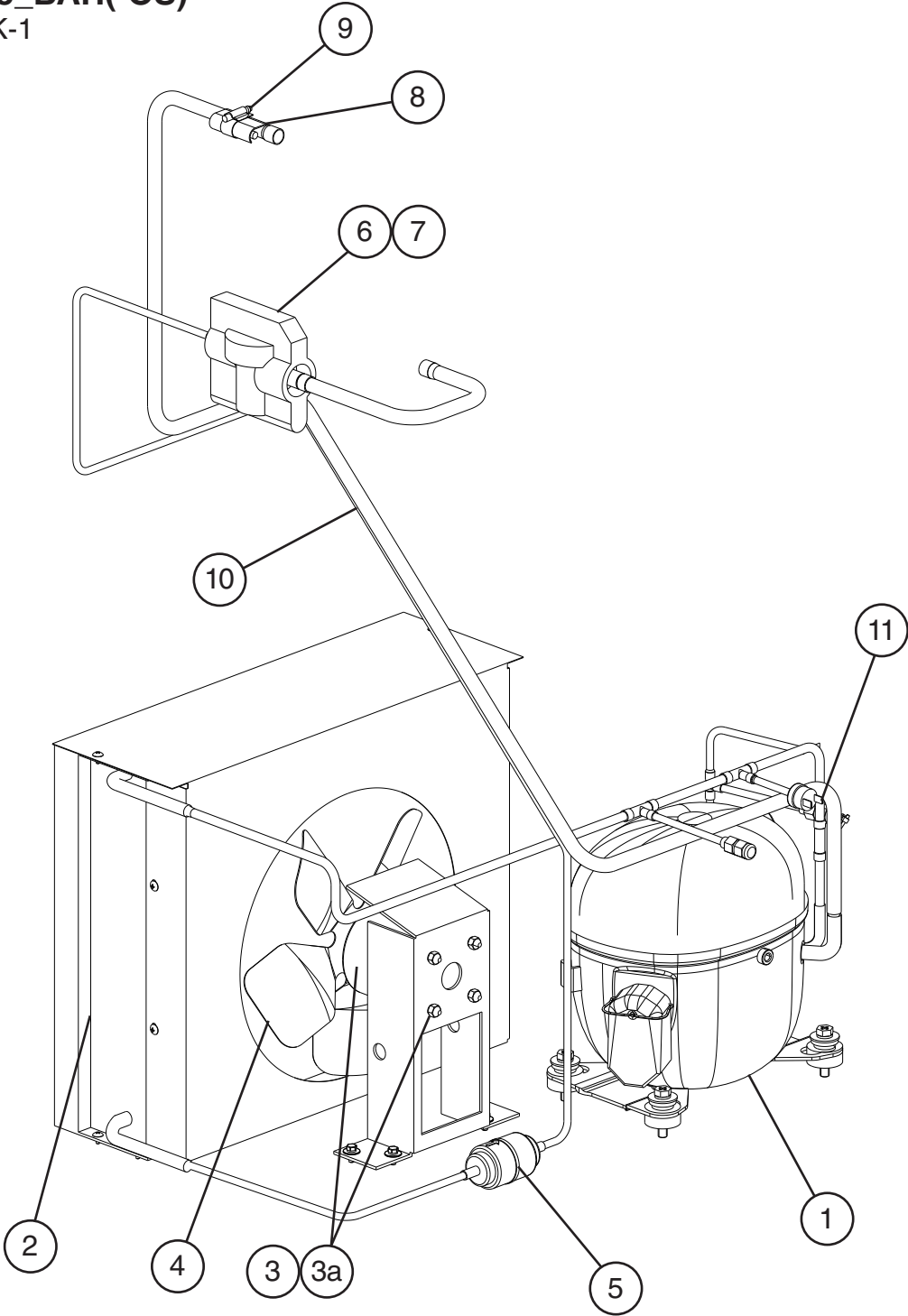

Title: B. Refrigeration Circuit Model: DCM-75_BAH(-OS)											
Index No.	Description	Material or Model Number	Part Number	A-0 to K-1	Required Number						
1	Compressor	DCM-751BAH(-OS)	4A5158-01	1							
		DCM-752BAH(-OS)	4A4376-02	1							
2	Condenser		3A0821-01	1							
3	Fan Motor	DCM-751BAH(-OS)	4A3158-01	1							
		DCM-752BAH(-OS)	4A6115-01	1							
3a	Self-Locking Nut	DCM-751BAH(-OS)	7N21I0832	4							
4	Fan Blade		444898-01	1							
5	Drier		4A1113-01	1							
6	Thermostatic Expansion Valve	DCM-751BAH(-OS)	4A1117-01	1							
		DCM-752BAH(-OS)	4A3493-01	1							
7	Thermostatic Expansion Valve Cover		4A1168-01	1							
8	Thermostatic Expansion Valve Bulb Holder	DCM-751BAH(-OS)	3A0112-01	1							
9	Clamp	DCM-751BAH(-OS)	443461-01	1							
		DCM-752BAH(-OS)	4A5641-01	1							
10	Heat Exchanger		2A6126A01	1							
11	High-Pressure Switch		463180-04	1							

B. Refrigeration Circuit
DCM-751BWH(-OS)
A-0 to K-1

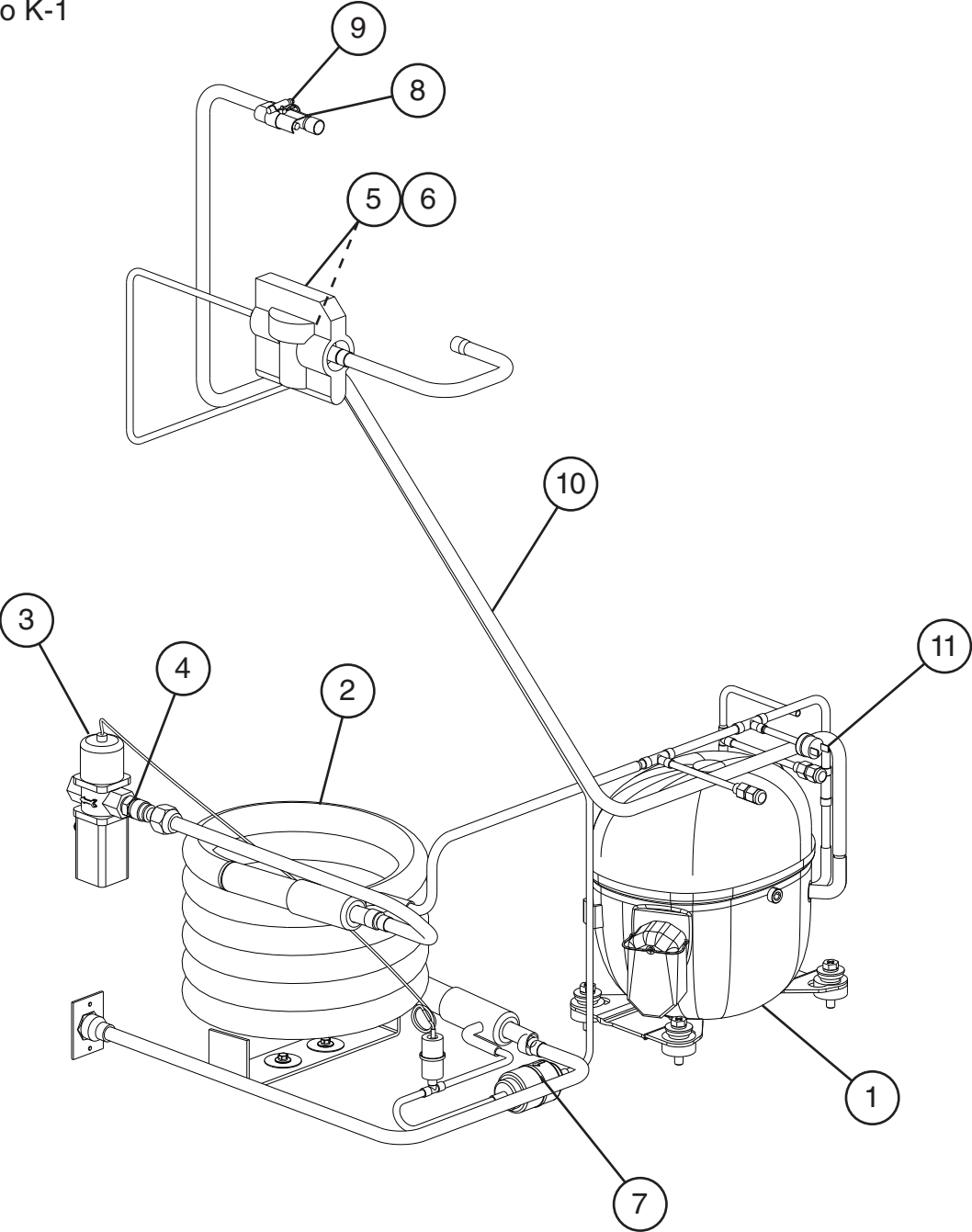

Title: B. Refrigeration Circuit Model: DCM-751BWH(-OS)											
Index No.	Description	Material or Model Number	Part Number	Required Number							
				A-0 to B-0	C-1 to K-1						
1	Compressor		4A5158-01	1	1						
2	Water-Cooled Condenser	HS-5099	2A2359G03	1	-						
			3A7323-01		1						
3	Water Regulator		4A0911-04	1	1						
4	Male Connector		4A1087-01	1	1						
5	Thermostatic Expansion Valve		4A1117-01	1	1						
6	Thermostatic Expansion Valve Cover		4A1168-01	1	1						
7	Drier		4A1113-01	1	1						
8	Thermostatic Expansion Valve Bulb Holder		3A0112-01	1	1						
9	Clamp		443461-01	1	1						
10	Heat Exchanger		2A6126A01	1	1						
11	High-Pressure Switch		463180-05	1	1						

C. Ice Making Unit
DCM-751B_H(-OS), DCM-752BAH(-OS)
A-0 to K-1

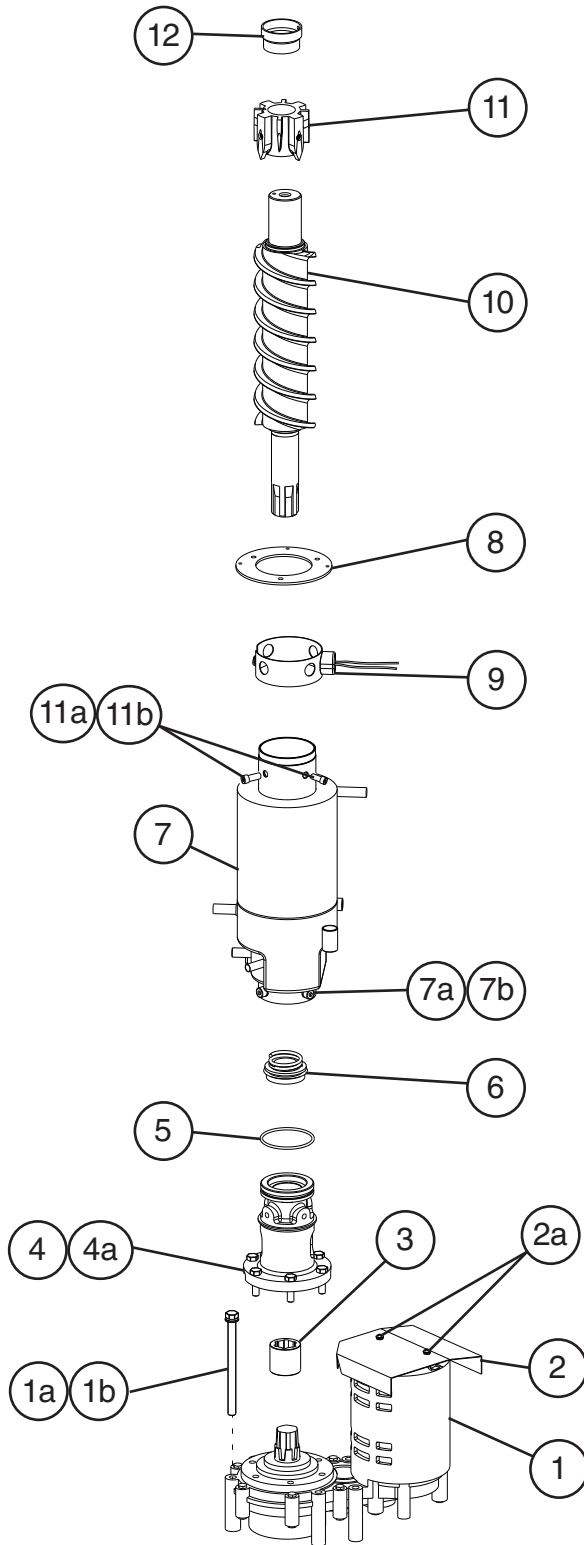

Title: C. Ice Making Unit Model: DCM-751B_H(-OS), DCM-752BAH(-OS)

Index No.	Description	Material or Model Number	Part Number	A-0 to K-1	Required Number									
1	Gear Motor		4A2007-01	1										
1a	Socket Head Cap Screw	8x110	7S12-0811	3										
1b	Split Lock Washer	M8	7L22-0800	3										
2	Gear Motor Barrier		3A1732-01	1										
2a	Truss Head Screw	4x8	7C31-0408	2										
2b	Rubber Washer		4A5268-01	2										
3	Spline Coupling		4A3204-01	1										
4	Housing		2A1977G01	1										
4a	Hex Bolt	8x30	7B02-0830	6										
5	O-ring		4A4755-02	1										
6	Mechanical Seal		432492-01	1										
7	Evaporator		2A3314G01	1										
7a	Socket Head Cap Screw	8x12	7S12-0812	4										
7b	Split Lock Washer		7L22-0800	4										
8	Packing		427151-02	1										
9	Evaporator Heater (includes spring)		4A2292-01	1										
10	Auger		120863G02	1										
11	Extruding Head		216530G07	1										
11a	Washer		427184-01	4										
11b	Seal Bolt		P01768-02	4										
12	Cutter		427183G01	1										

D. Water Circuit
DCM-751B_H(-OS), DCM-752BAH(-OS)
 A-0 to K-1

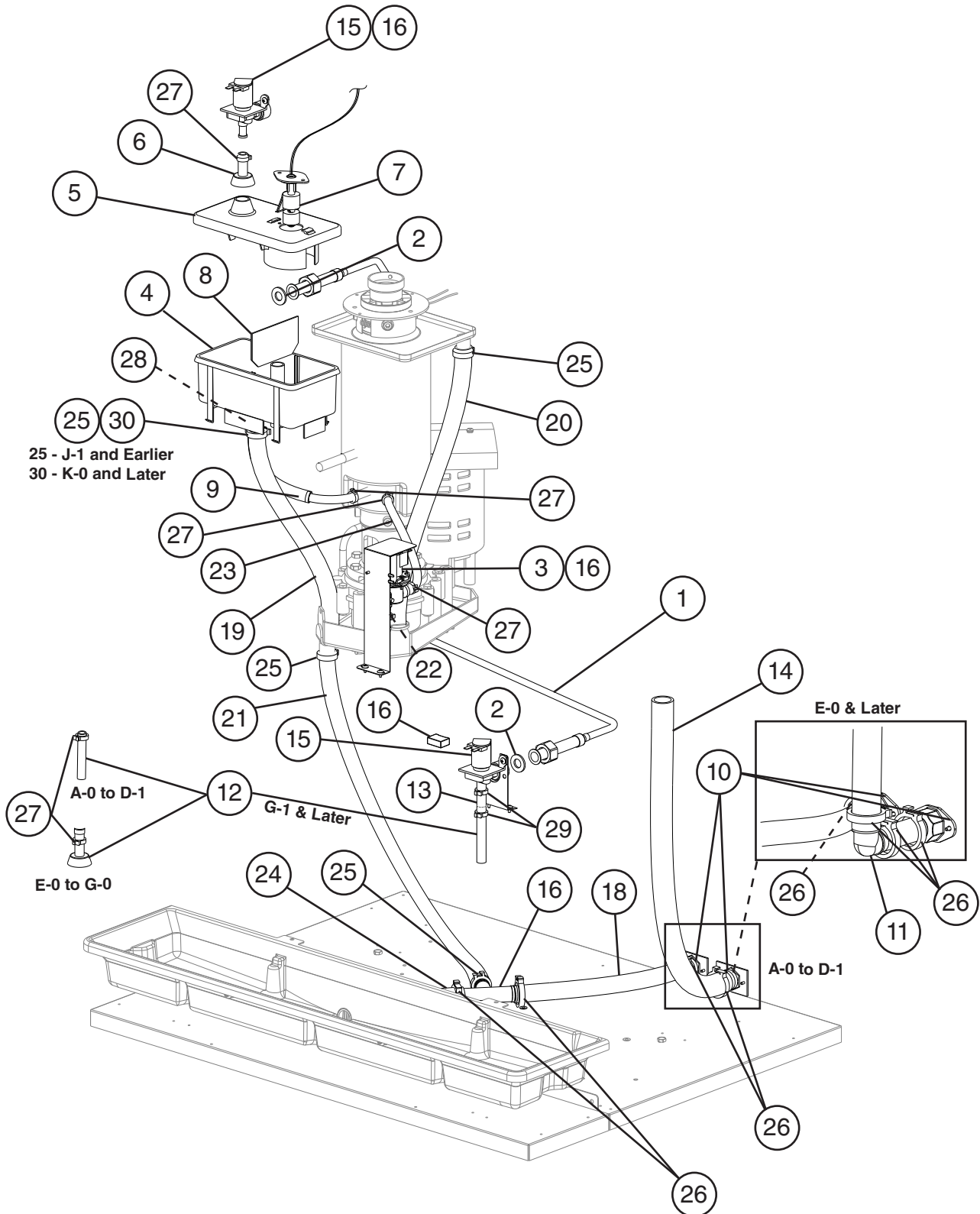

Title: D. Water Circuit Model: DCM-751B_H(-OS), DCM-752BAH(-OS)												
Index No.	Description	Material or Model Number	Part Number	Required Number								
				A-0 to D-1	E-0 to G-0	G-1 to G-1(J)	G-1(K) to J-0(C)	J-0(D) to J-1	K-0 K-1			
1	Water Supply Pipe		2A6154G01	1	-							
			2A6154G02		1	1	1	1	1			
2	Washer		4A0867-01	2	-							
	Rubber Gasket		413854-03		2	2	2	2	2			
3	Drain Valve		4A2772-01	1	1	1	1	1	1			
4	Reservoir		2A0753-01	1	1	1	1	1	1			
5	Reservoir Cover		214810-01	1	1	1	1	1	1			
6	Reservoir Inlet		4A0869-01	1	1	1	1	1	1			
7	Float Switch		435490-01	1	1	1	1	1	1			
8	Reservoir Seperator		4A1255-01	1	1	1	1	1	1			
9	Reservoir Hose		4A1165-04	1	1	1	1	1	1			
10	Drain Fitting		4A0776G01	2	-							
			4A5527-01		2	2	2	2	2			
11	Elbow		4A1016-01		1	1	1	1	1			
12	Vinyl Hose	L=70 mm	7725-0912	1	-							
	Reservoir Inlet		4A0869-01		1	-						
	Water Tube		4A3218-01			1	1	1	1			
13	Silicone Hose	L=60 mm	7730-0912			1	1	1	1			
14	Vinyl Hose	L=515 mm	4A0658L01	1	-							
		L=425 mm			1	1	1	1	1			
15	Water Valve (inlet and dispense)		4A0865-01	2	-							
			4A5309-01		2	2	2	2	2			
16	R-C Capacitor (Noise Killer)	0.2MFD, 250VAC	4A1012-01	3	3	3	-					
			4A4472-01				3	-				
		0.1MFD, 250VAC	4A6495-01					3	3			
17	Tee		4A0525-04	1	1	1	1	1	1			
18	Vinyl Hose	L=265 mm	7716-2025	1	-							
		L=380 mm			1	1	1	1	1			
19	Vinyl Hose	L=350 mm	7716-2025	1	-							
			7725-1923		1	1	1	1	1			
20	Vinyl Hose	L=435 mm	7716-2025	1	-							
			7725-1923		1	1	1	1	1			
21	Vinyl Hose	L=550 mm	7725-1923	1	-							
		L=585 mm			1	1	1	1	1			
22	Vinyl Hose	L=75 mm	7725-0912	1	-							
	Silicone Hose	L= 100 mm	7730I3896		1	1	1	1	1			
23	Vinyl Hose	L=175 mm	7725-0912	1	-							
	Silicone Hose	L=225 mm	7730I3896		1	1	1	1	1			
24	Vinyl Hose	L=220 mm	4A0658L01	1	1	1	1	1	1			
Clamps												
25	Hose Clamp	21-26 mm	4A2017-01	4	4	4	4	4	3			
26	Hose Clamp	32-37 mm	4A2017-03	5	6	6	6	6	6			
27	Hose Clamp	12-14 mm	4A2017-04	6	6	5	5	5	5			
28	Hose Clamp	17-21 mm	4A2017-05	1	1	1	1	1	1			
29	Hose Clamp	13-15 mm	4A2017-08			2	2	2	2			
30	Hose Clamp	22-25 mm	4A2017-09						1			

E. Control Box Assembly
DCM-751B_H(-OS), DCM-752BAH(-OS)
A-0 to K-1

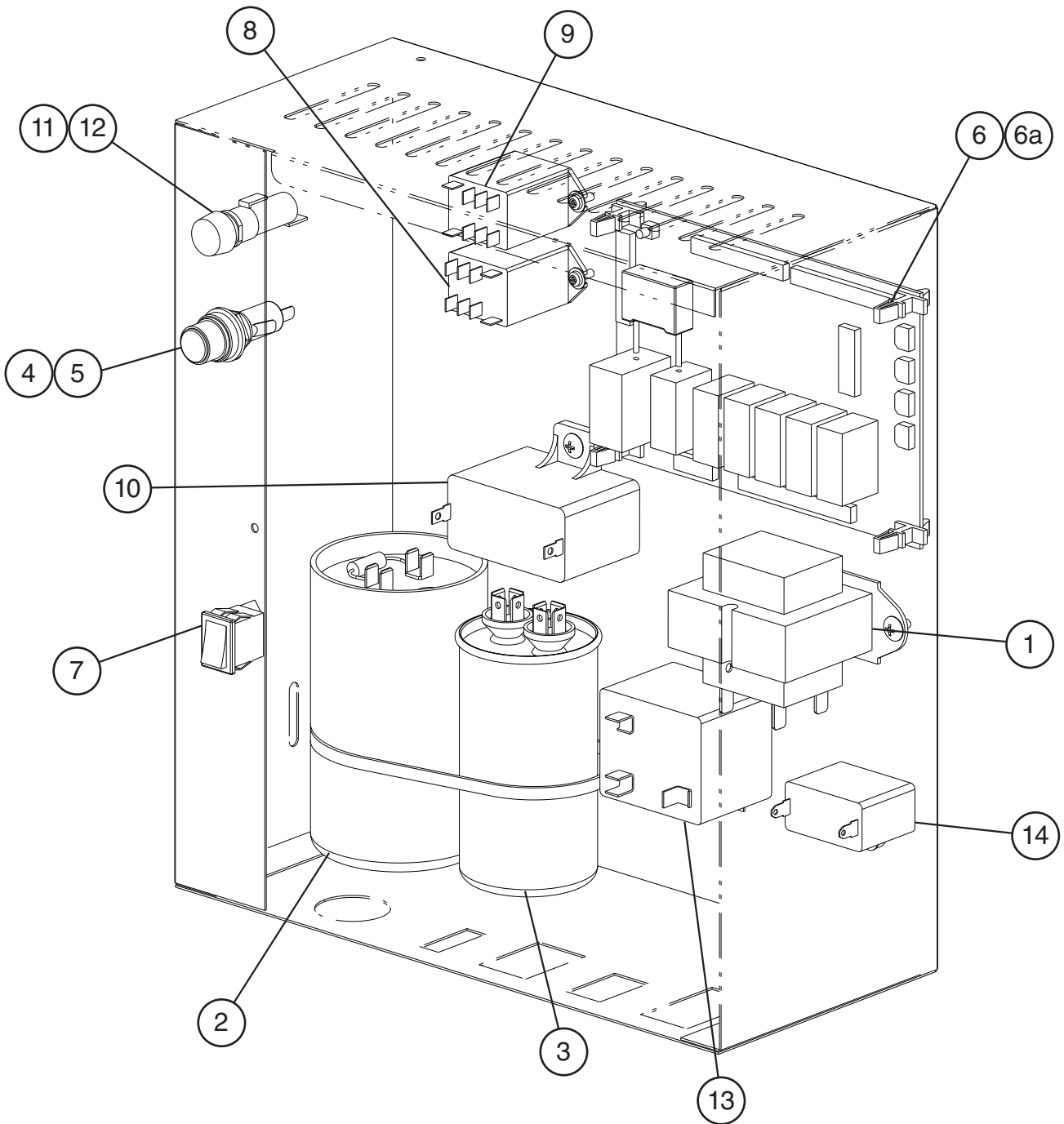

Title: E. Control Box Assembly Model: DCM-751B_H(-OS), DCM-752BAH(-OS)										
Index No.	Description	Material or Model Number	Part Number	Required Number						
				A-0 to D-0	D-1 to G-1 (L)	G-1 (M) to J-1	K-0 K-1			
1	Control Transformer		4A0557-01	1	1	1	1			
2	Start Capacitor	DCM-751B_H(-OS) 243-292MFD, 250VAC	3A0076-21	1	1	1	1			
		DCM-752BAH(-OS) 243-292MFD, 165VAC	3A0076-20				1			
3	Run Capacitor	DCM-751B_H(-OS) 40MFD, 440VAC	3A2005-07	1	1	1	1			
		DCM-752BAH(-OS) 35MFD, 440VAC	3A2005-12				1			
4	Fuse Holder		4A3449-02	1	-					
			4A5443-01		1	1	1			
5	Control Board Fuse	AGC-1A, 250VAC	4A0893-01	1	1	1	1			
6	Control Board		2A9093-01	1	1	1	1			
6a	Control Board Support		4A0336-03	4	4	4	4			
7	Rocker Switch (power)		4A0558-01	1	1	1	1			
8	Gear Motor Protect Relay		4A6558-01	1	1	1	1			
9	Power Protect Relay	220-240VAC	418271-05	1	1	1	1			
10	Gear Motor Capacitor	24MFD, 250VAC	4A2273-01	1	1	1	1			
11	Gear Motor Fuse *See Below	GMD-3A, 250VAC (fast acting)	4A0893-03	1	-					
		GMD-3A, 250VAC (time delay)	4A0893-06		1	1	1			
12	Fuse Holder *See Below	GMD-3A, 250VAC (fast acting)	4A5443-01	1	-					
		GMD-3A, 250VAC (time delay)	4A6101-01		1	1	1			
13	Start Relay	DCM-751B_H(-OS)	4A1107-20	1	1	1	1			
		DCM-752BAH(-OS)	4A1107-11				1			
14	Fan Motor Capacitor	DCM-751BAH(-OS) 5MFD, 250VAC	4A6435-02	1	1	1	1			

*If the gear motor fuse trips frequently and component and/or wiring issues are eliminated as the cause, replace both the gear motor fuse holder and the gear motor fuse. Reference Service Bulletin SB14-0009R1.

SB14-0009R1 outlines replacement of the original fast acting fuse and associated fuse holder with a slow blow fuse and new fuse holder.

This revision and service bulletin affects the following models:

DCM-751BAH: D00221B and earlier

DCM-751BAH-OS: D00104C and earlier

DCM-751BWH: C10028G and earlier

DCM-751BWH-OS: C10012H; B00010F and earlier

F. Shutter Assembly DCM-751B_H(-OS)

1/2

A-0 to K-1

DCM-751BAH(-OS): C-0(L) and Earlier

DCM-751BWH(-OS): C-1(L) and Earlier

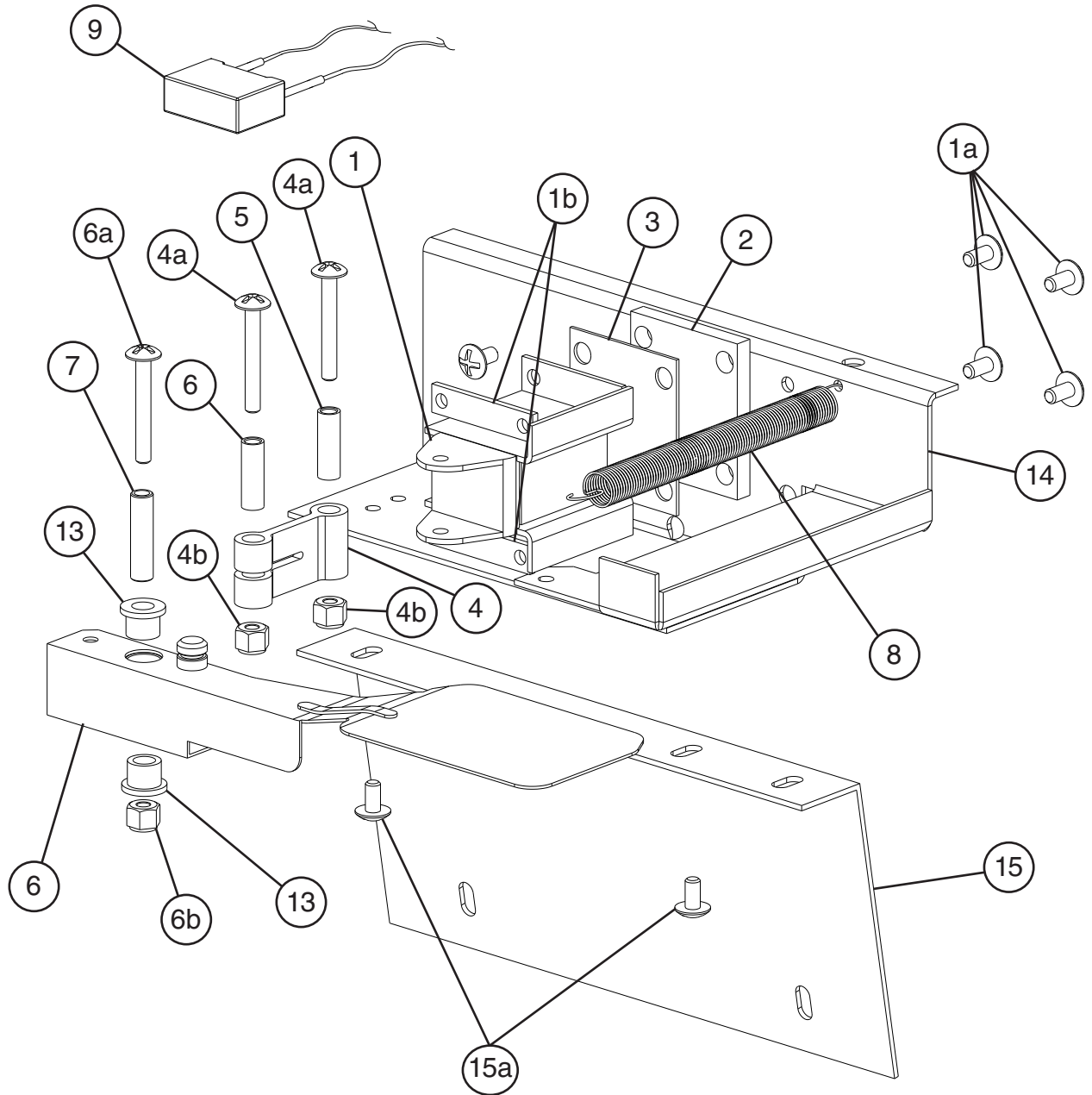

F. Shutter Assembly
DCM-751B_H(-OS), 752BAH(-OS)
2/2

A-0 to K-1

DCM-751BAH(-OS): C-0(M) and Later, DCM-752BAH(-OS)

DCM-751BWH(-OS): C-1(M) and Later

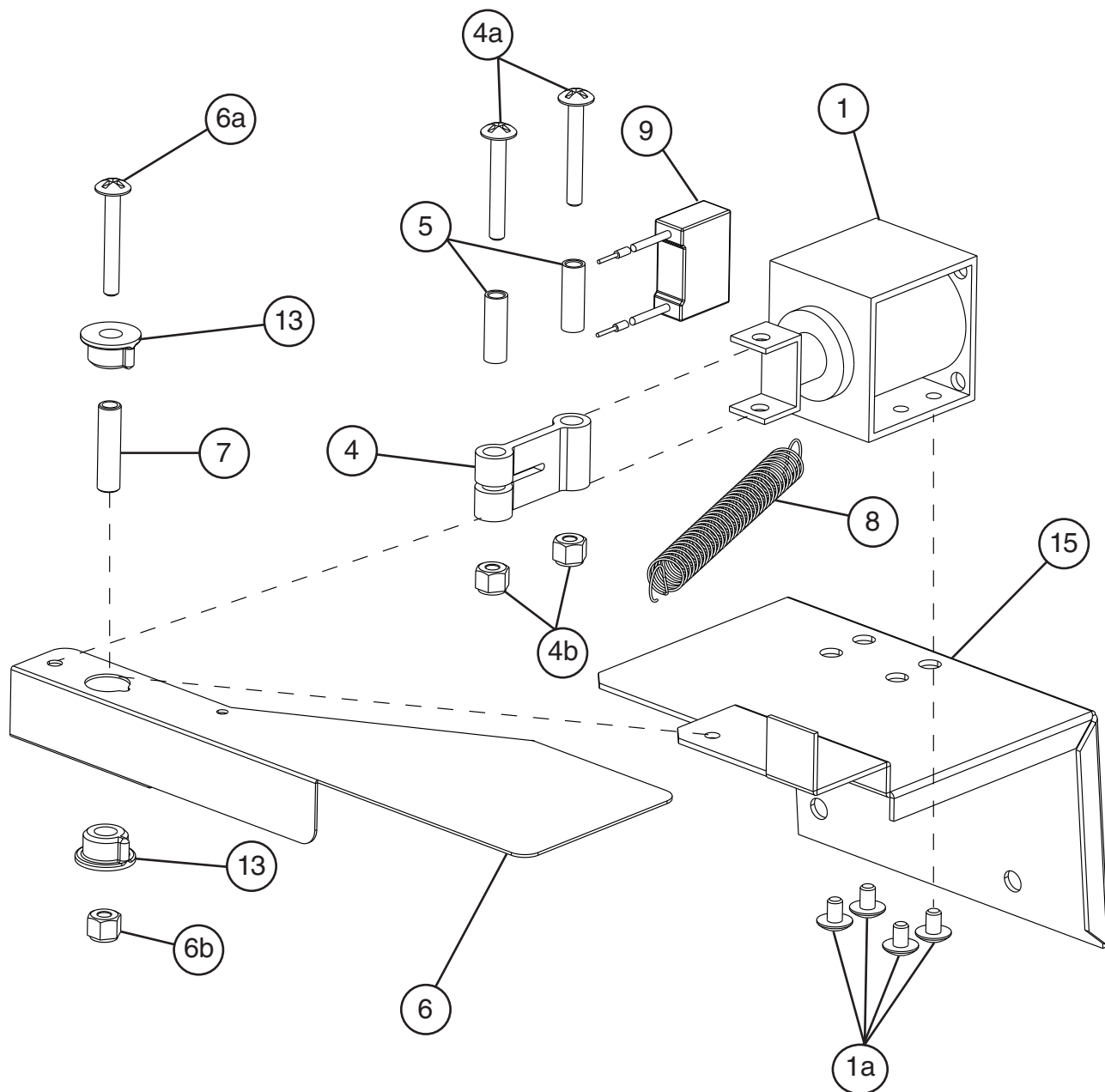

Title: F. Shutter Assembly Model: DCM-751B_H(-OS), DCM-752BAH(-OS)

Index No.	Description	Material or Model Number	Part Number	Required Number									
				A-0 to C-0(L) C-1(L)	C-0(M) C-1(M) to G-1(J)	G-1(K) to J-0(C)	J-0(D) to K-1						
1	Dispense Solenoid		3U0095-01	1	-								
			4A0856-01		1	1	1						
1a	Truss Head Screw	4x12	7C32-0412	4	-								
		4x6	7C32-0406		4	4	4						
1b	Solenoid Nut		429723-01	2	-								
2	Dispense Solenoid Packing		430380-01	1	-								
3	Packing Cover		431623-01	1	-								
4	Link		432232-01	1	1	1	1						
4a	Truss Head Screw	4x30	7C32-0430	2	2	2	2						
4b	Self-Locking Nut		7N22-0400	2	2	2	2						
5	Collar D		432471-01	2	2	2	2						
6	Lever		3A1653G01	1	-								
			3A6139-01		1	1	1						
6a	Truss Head Screw	4x30	7C32-0430	1	1	1	1						
6b	Self-Locking Nut		7N22-0400	1	1	1	1						
7	Collar E		432240-02	1	1	1	1						
8	Spring		432878-01	1	1	1	1						
9	R-C Capacitor (Noise Killer)	0.2MFD, 250VAC	4A1012-01	3	3	-							
			4A4472-01			3	-						
		0.1MFD, 250VAC	4A6495-01					3					
10	Truss Head Screw (GND)	4x8	7C32-0408	1	-								
11	Tooth Washer (GND)		7R22-0400	1	-								
12	Hex Nut (GND)		7N11-0400	1	-								
			432235-01	2	-								
13	Plastic Sleeve Insert		435533-01		2	2	2						
			2A2030-02	1	-								
14	Shutter Base		2A2030-02	1	-								
15	Shutter Base B		341011-01	1	-								
			3A7964-01		1	1	1						
15a	Truss Head Screw	4x8	7C32-0408	2	-								

G. Dispensing & Agitating Gear Motor Assemblies
DCM-751B_H(-OS), 752BAH(-OS)
A-0 to K-1

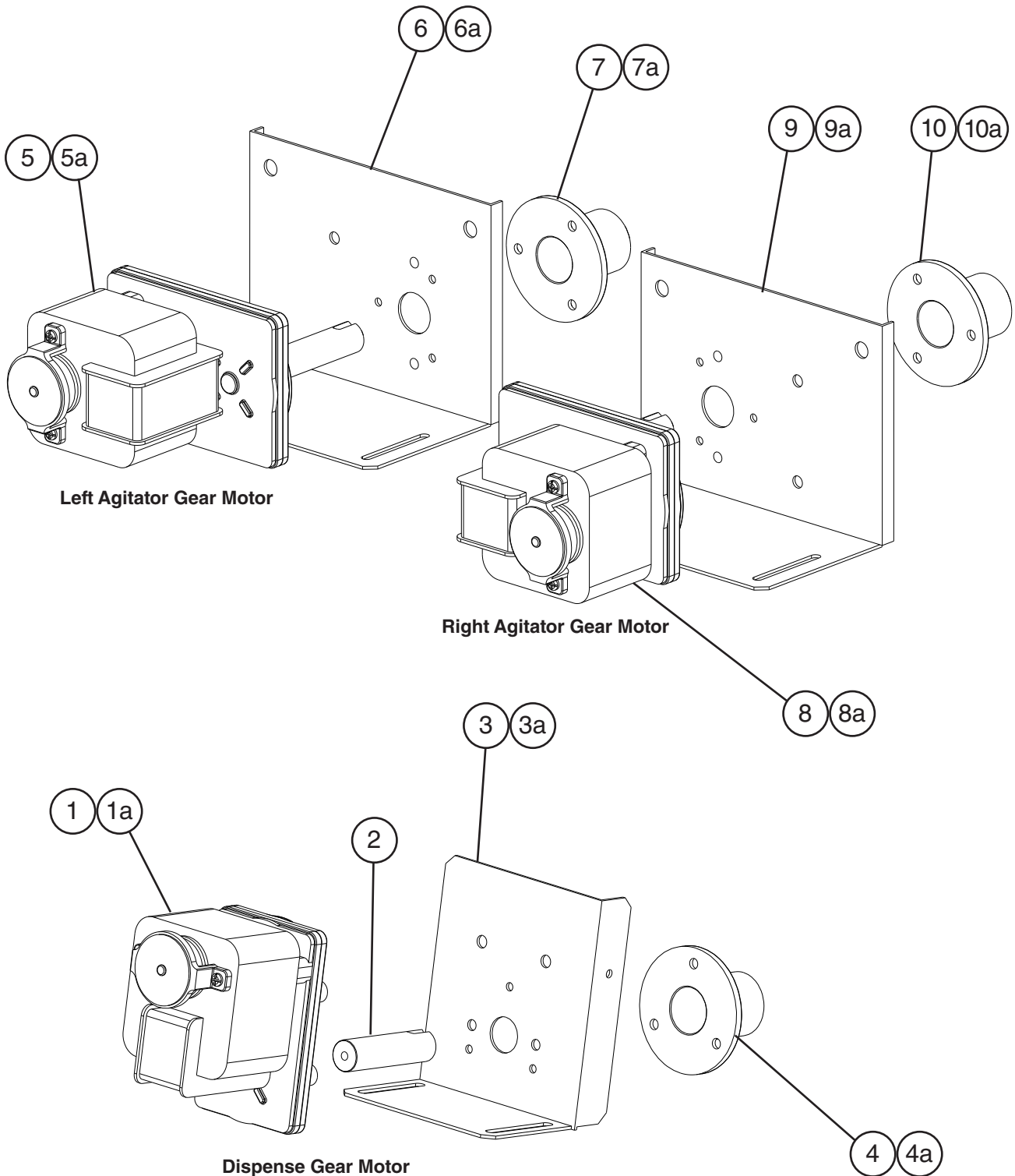

Title: G. Dispensing & Agitating Gear Motor Assemblies Model: DCM-751B_H(-OS), DCM-752BAH(-OS)											
Index No.	Description	Material or Model Number	Part Number	A-0 to K-1	Required Number						
1	Dispensing Gear Motor		3A6786-03	1							
1a	Flat Head Screw	4x6	7C22-0406	4							
2	Joint		429764-01	1							
3	Center Gear Motor Bracket		340989-01	1							
3a	Thumbscrew		415949G11	3							
4	Plastic Sleeve		429761-01	1							
4a	Flat Head Screw	4x8	7C22-0408	3							
5	Left Agitating Gear Motor		4A3122-01	1							
5a	Flat Head Screw	4x6	7C22-0406	4							
6	Left Gear Motor Bracket		4A3733-01	1							
6a	Thumbscrew		415949G11	3							
7	Plastic Sleeve		429761-01	1							
7a	Flat Head Screw	4x8	7C22-0408	3							
8	Right Agitating Gear Motor		4A3122-01	1							
8a	Flat Head Screw	4x6	7C22-0406	4							
9	Right Gear Motor Bracket		4A3734-01	1							
9a	Thumbscrew		415949G11	3							
10	Plastic Sleeve		429761-01	1							
10a	Flat Head Screw	4x8	7C22-0408	3							

H. Bin Assembly
DCM-751B_H(-OS), 752BAH(-OS)
A-0 to K-1

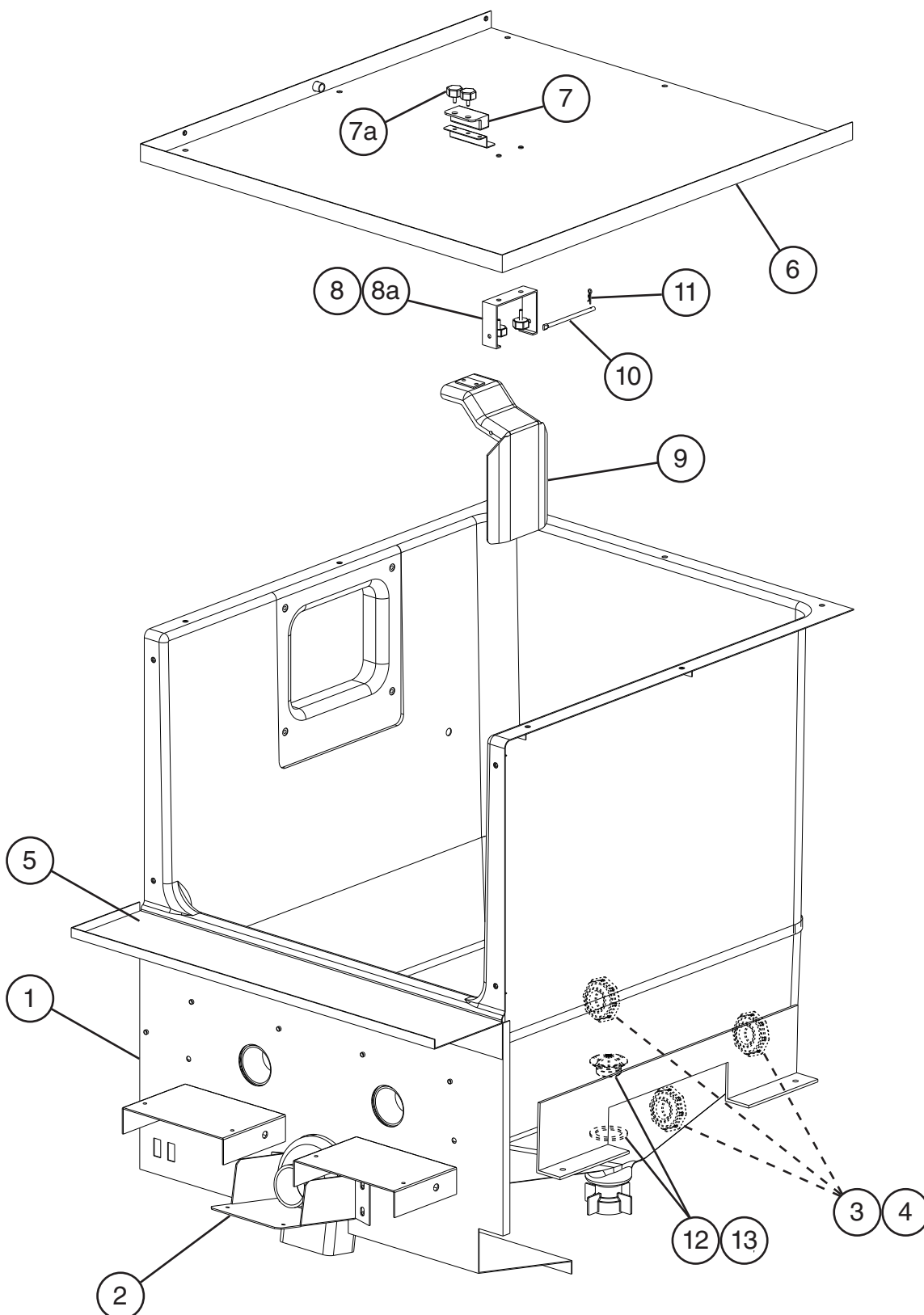

Title: H. Bin Assembly Model: DCM-751B_H(-OS), DCM-752BAH(-OS)												
Index No.	Description	Material or Model Number	Part Number	A-0 to K-1	Required Number							
1	Barrier		228453G01	1								
2	Sliding Bracket		340986-01	1								
3	O-ring		7616-P032	3								
4	Shaft Holder		429818-01	3								
5	Motor Barrier		340984-01	1								
6	Bin Top Cover		2A1713G01	1								
7	Mechanical Bin Control Proximity Switch		4A2033-01	1								
7a	Thumbscrew		415949G08	2								
8	Bin Control Bracket		3A0762-01	1								
8a	Thumbscrew		415949G08	2								
9	Actuator		208795G01	1								
10	Shaft		412337-03	1								
11	Snap Pin		715S-0004	1								
12	Drain Cap		418294-01	1								
13	Rubber Packing (B)		413857-02	1								

J. Accessories & Labels
DCM-751B_H(-OS), 752BAH(-OS)
 A-0 to K-1

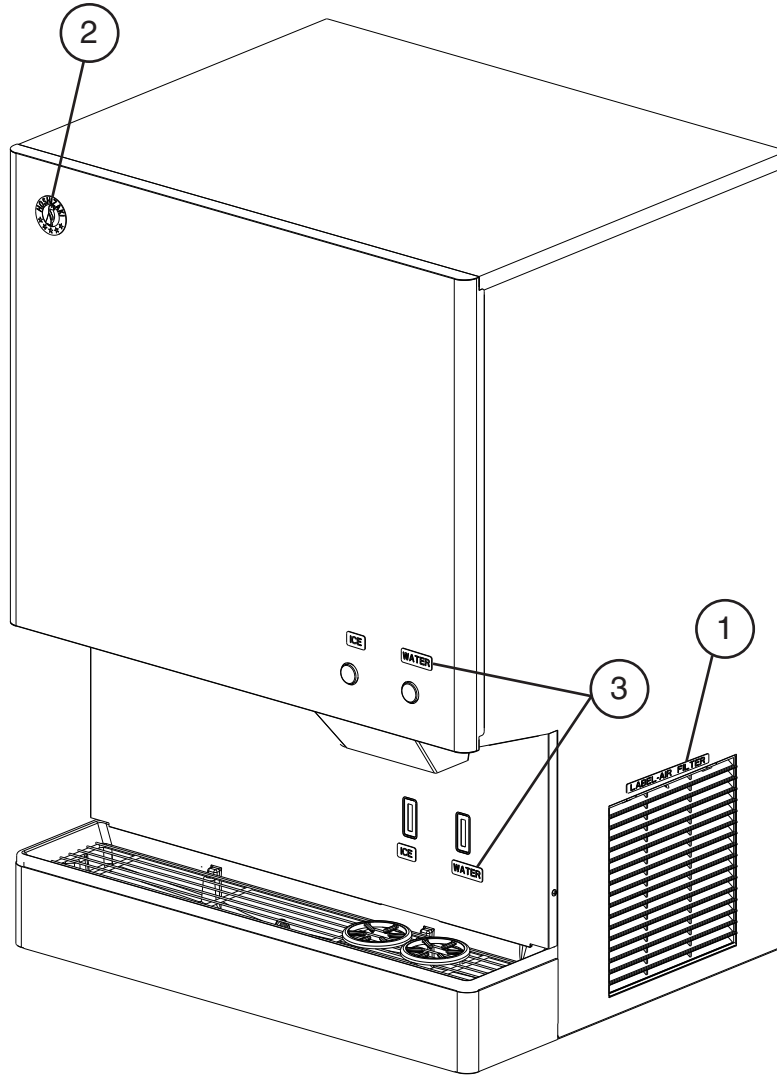

Title: J. Accessories & Labels Model: DCM-751B_H(-OS), DCM-752BAH(-OS)					Required Number								
Index No.	Description	Material or Model Number	Part Number	A-0 to K-1									
1	Air Filter Label	DCM-75_BAH(-OS)	426177-01	2									
2	Penguin Label		475552L02	1									
3	Ice-Water Label		4A2954-01	1									