

NO: 73071
ISSUED: MAR. 11, 1999
REVISED: DEC. 17, 2003



HOSHIZAKI CUBELET ICE DISPENSER

**MODEL DCM-500BAF
DCM-500BWF
DCM-750BAF
DCM-750BWF**

SERVICE MANUAL

IMPORTANT

Only qualified service technicians should attempt to service or maintain this icemaker. No service or maintenance should be undertaken until the technician has thoroughly read this Service Manual.

HOSHIZAKI provides this manual primarily to assist qualified service technicians in the service and maintenance of the icemaker.

Should the reader have any questions or concerns which have not been satisfactorily addressed, please call or write to the HOSHIZAKI Technical Support Department for assistance.

HOSHIZAKI AMERICA, INC.
618 Highway 74 South
Peachtree City, GA 30269

Attn: HOSHIZAKI Technical Support Department

Phone: 1-800-233-1940 Technical Service
(770) 487-2331
Fax: (770) 487-3360

NOTE: To expedite assistance, all correspondence/communication **MUST** include the following information:

- Model Number
- Serial Number
- Complete and detailed explanation of the problem

- Please review this manual. It should be read carefully before the ice dispenser is installed and operated. Only qualified service technicians should install, service and maintain the ice dispenser. This manual should be made available to the technician prior to installation, service or maintenance.

CONTENTS	PAGE
I. SPECIFICATIONS	5
1. DCM-500BAF (Air-cooled)	5
2. DCM-500BWF (Water-cooled)	6
3. DCM-750BAF (Air-cooled)	7
4. DCM-750BWF (Water-cooled)	8
II. GENERAL INFORMATION	9
1. CONSTRUCTION	9
DCM-500BAF, DCM-750BAF	9
DCM-500BWF, DCM-750BWF	10
2. CONTROL BOX LAYOUT	11
DCM-500BAF, DCM-750BAF	11
DCM-500BWF, DCM-750BWF	12
3. CABINET STAND	13
III. TECHNICAL INFORMATION	16
1. WATER CIRCUIT AND REFRIGERANT CIRCUIT	16
DCM-500BAF (Air-cooled)	16
DCM-500BWF (Water-cooled)	17
DCM-750BAF (Air-cooled)	18
DCM-750BWF (Water-cooled)	19
2. WIRING DIAGRAM	20
DCM-500BAF, DCM-500BWF	20
DCM-750BAF, DCM-750BWF	21
3. SEQUENCE OF ELECTRICAL CIRCUIT	22
4. TIMING CHART	36
5. TIMER BOARD	37
6. PERFORMANCE DATA	41
IV. ADJUSTMENT OF COMPONENTS	45
ADJUSTMENT OF WATER REGULATING VALVE	
- WATER-COOLED MODEL ONLY	45
V. SERVICE DIAGNOSIS	46

VI. REMOVAL AND REPLACEMENT OF COMPONENTS	50
1. SERVICE FOR REFRIGERANT LINES.....	50
[a] REFRIGERANT RECOVERY	50
[b] EVACUATION AND RECHARGE [R-404A].....	50
2. BRAZING	51
3. REMOVAL AND REPLACEMENT OF COMPRESSOR	52
4. REMOVAL AND REPLACEMENT OF DRIER	53
5. REMOVAL AND REPLACEMENT OF EXPANSION VALVE	54
6. REMOVAL AND REPLACEMENT OF WATER REGULATING VALVE	55
7. REMOVAL AND REPLACEMENT OF EVAPORATOR ASSEMBLY	56
8. REMOVAL AND REPLACEMENT OF FAN MOTOR	61
9. REMOVAL AND REPLACEMENT OF CONTROL/DISPENSING WATER VALVE	61
10. REMOVAL AND REPLACEMENT OF FLOAT SWITCH	62
11. REMOVAL AND REPLACEMENT FLUSH WATER VALVE	62
12. REMOVAL AND REPLACEMENT OF ELECTRICAL SYSTEM	63
13. REMOVAL AND REPLACEMENT OF DISPENSING SYSTEM	64
VII. CLEANING AND MAINTENANCE INSTRUCTIONS	66
1. PREPARING THE ICE DISPENSER FOR LONG STORAGE	66
2. CLEANING INSTRUCTIONS	68
[a] WATER SYSTEM	68
[b] STORAGE BIN.....	70
[c] WATER VALVE	72
[d] STRAINER	73
3. MAINTENANCE INSTRUCTIONS	75

I. SPECIFICATIONS

1. DCM-500BAF (Air-cooled)

AC SUPPLY VOLTAGE	115/60/1		
COMPRESSOR	120 V	7.9 RLA	51 LRA
GEAR MOTOR	120 V	1.6 FLA	1/6 HP
FAN MOTOR	120 V	0.6 FLA	30W
AGITATING MOTOR	120 V	0.9 FLA	55 W
DISPENSING MOTOR	120 V	0.9 FLA	55 W
OTHERS	120 V	0.2 A	
MAXIMUM FUSE SIZE	20 A		
MAX. HACR BREAKER (USA ONLY)	20 A		
MAX. CIRC. BREAKER (CANADA ONLY)	20 A		
MINIMUM CIRCUIT AMPACITY	20 A		
APPROXIMATE ICE PRODUCTION PER 24 HR. lbs./day (kg/day) Reference without *marks	Ambient Temp.(°F)	WATER TEMP. (°F)	
		50	70
		90	
	70	*525 (243)	510 (231)
	80	461 (209)	438 (199)
	90	396 (179)	*385 (175)
	100	340 (154)	323 (147)
		*304 (138)	
SHAPE OF ICE	Cubelet (Compressed Flake Ice)		
ICE QUALITY	Approx. 90%, Ice (90/70°F, Conductivity 200 µs/cm)		
APPROXIMATE STORAGE CAPACITY	40 lbs.		
ELECTRIC & WATER CONSUMPTION	90/70°F	70/50°F	
ELECTRIC W (kWH/100 lbs.)	1055 (6.6)	985 (4.4)	
POTABLE WATER gal./24HR (gal./100 lbs.)	46 (11.9)	64 (11.9)	
EXTERIOR DIMENSIONS (WxDxH)	26" x 22-1/2" x 40" (661 x 571 x 1016 mm)		
EXTERIOR FINISH	Stainless Steel, Galvanized Steel (Rear)		
WEIGHT	Net 251 lbs. (114 kg), Shipping 276 lbs. (125 kg)		
CONNECTIONS - ELECTRIC	Permanent - Connection		
- WATER SUPPLY	Inlet 1/2" FPT		
- DRAIN	Outlet 3/4" FPT x2		
ICE MAKING SYSTEM	Auger type		
HARVESTING SYSTEM	Direct Driven Auger (1/6 HP Gear Motor)		
ICE MAKING WATER CONTROL	Float Switch		
COOLING WATER CONTROL	N/A		
BIN CONTROL SYSTEM	Mechanical Bin Control (Proximity Sw.)		
COMPRESSOR	Hermetic, Model R43C1E-CAA-219		
CONDENSER	Air-cooled, Fin and tube type		
EVAPORATOR	Copper Tube on Cylinder		
REFRIGERANT CONTROL	Thermostatic Expansion Valve		
REFRIGERANT CHARGE	R-404A, 1 lb. 4.1 oz. (570g)		
DESIGN PRESSURE	High 460 PSIG, Low 290 PSIG		
P.C. BOARD CIRCUIT PROTECTION	High Voltage Cut-out Relay		
COMPRESSOR PROTECTION	Auto-reset Overload Protector		
GEAR MOTOR PROTECTION	Auto-reset Thermal Protector		
	Manual reset Circuit Breaker or Fuse		
REFRIGERANT CIRCUIT PROTECTION	Auto-reset High Pressure Control Switch		
LOW WATER PROTECTION	Float Switch and Timer		
ACCESSORIES -SUPPLIED	Spare Fuse		
-REQUIRED	Legs		
OPERATING CONDITIONS	VOLTAGE RANGE	104 - 127 V	
	AMBIENT TEMP.	45 - 100° F	
	WATER SUPPLY TEMP.	45 - 90° F	
	WATER SUPPLY PRESSURE	10 - 113 PSIG	
DRAWING NO. (DIMENSION)	340147S--		

We reserve the right to make changes in specifications and design without prior notice.

2. DCM-500BWF (Water-cooled)

AC SUPPLY VOLTAGE	115/60/1		
COMPRESSOR	120 V	7.9 RLA	51 LRA
GEAR MOTOR	120 V	1.6 FLA	1/6 HP
AGITATING MOTOR	120 V	0.9 FLA	55 W
DISPENSING MOTOR	120 V	0.9 FLA	55 W
OTHERS	120 V	0.2 A	
MAXIMUM FUSE SIZE	20 A		
MAX. HACR BREAKER (USA ONLY)	20 A		
MAX. CIRC. BREAKER (CANADA ONLY)	20 A		
MINIMUM CIRCUIT AMPACITY	20 A		
APPROXIMATE ICE PRODUCTION PER 24 HR. lbs./day (kg/day) Reference without *marks	Ambient Temp.(°F)	WATER TEMP. (°F)	
		50	70
	70	*545 (247)	526 (239)
	80	503 (228)	493 (223)
	90	471 (214)	*465 (211)
	100	441 (200)	*400 (181)
SHAPE OF ICE	Cubelet (Compressed Flake Ice)		
ICE QUALITY	Approx. 90%, Ice (90/70°F, Conductivity 200 µs/cm)		
APPROXIMATE STORAGE CAPACITY	40 lbs.		
ELECTRIC & WATER CONSUMPTION	90/70°F	70/50°F	
ELECTRIC W (kWH/100 lbs.)	930 (4.8)	985 (4.0)	
POTABLE WATER	56 (12)	65 (12)	
WATER-COOLED CONDENSER gal./24HR (gal./100 lbs.)	465 (100)	285 (52)	
EXTERIOR DIMENSIONS (WxDxH)	26" x 22-1/2" x 40" (661 x 571 x 1016 mm)		
EXTERIOR FINISH	Stainless Steel, Galvanized Steel (Rear)		
WEIGHT	Net 245 lbs. (111 kg), Shipping 269 lbs. (122 kg)		
CONNECTIONS - ELECTRIC	Permanent - Connection		
- WATER SUPPLY	Inlet 1/2" FPT Condenser Inlet 1/2" FPT		
- DRAIN	Outlet 3/4" FPT x2 Condenser Outlet 3/8" FPT		
ICE MAKING SYSTEM	Auger type		
HARVESTING SYSTEM	Direct Driven Auger (1/6 HP Gear Motor)		
ICE MAKING WATER CONTROL	Float Switch		
COOLING WATER CONTROL	Automatic Water Regulator		
BIN CONTROL SYSTEM	Mechanical Bin Control (Proximity Sw.)		
COMPRESSOR	Hermetic, Model R43C1E-CAA-219		
CONDENSER	Water-cooled, Double Tube Type		
EVAPORATOR	Copper Tube on Cylinder		
REFRIGERANT CONTROL	Thermostatic Expansion Valve		
REFRIGERANT CHARGE	R-404A, 13.4 oz. (380g)		
DESIGN PRESSURE	High 460 PSIG, Low 290 PSIG		
P.C. BOARD CIRCUIT PROTECTION	High Voltage Cut-out Relay		
COMPRESSOR PROTECTION	Auto-reset Overload Protector		
GEAR MOTOR PROTECTION	Auto-reset Thermal Protector		
	Manual-reset Circuit Breaker or Fuse		
REFRIGERANT CIRCUIT PROTECTION	Auto-reset High Pressure Control Switch		
LOW WATER PROTECTION	Float Switch and Timer		
ACCESSORIES -SUPPLIED	Spare Fuse		
-REQUIRED	Legs		
OPERATING CONDITIONS	VOLTAGE RANGE	104-127 V	
	AMBIENT TEMP.	45-100° F	
	WATER SUPPLY TEMP.	45-90° F	
	WATER SUPPLY PRESSURE	10-113 PSIG	
DRAWING NO. (DIMENSION)	340148S--		

We reserve the right to make changes in specifications and design without prior notice.

3. DCM-750BAF (Air-cooled)

AC SUPPLY VOLTAGE	115/60/1		
COMPRESSOR	120 V	11.1 RLA	60 LRA
GEAR MOTOR	120 V	3 FLA	1/4 HP
FAN MOTOR	120 V	0.85 FLA	1/15 HP
AGITATING MOTOR	120 V	1.8 FLA (Total)	110 W
DISPENSING MOTOR	120 V	0.9 FLA	55 W
OTHER	120 V	0.6 A	
MAXIMUM FUSE SIZE	20 A		
MAX. HACR BREAKER (USA ONLY)	20 A		
MAX. CIRC. BREAKER (CANADA ONLY)	20 A		
MINIMUM CIRCUIT AMPACITY	20 A		
APPROXIMATE ICE PRODUCTION PER 24 HR. lbs./day (kg/day) Reference without *marks	Ambient Temp.(°F)	WATER TEMP. (°F)	
		50	70
	70	* 803 (364)	770 (349)
	80	684 (310)	645 (293)
	90	573 (260)	* 567 (257)
	100	480 (218)	* 423 (192)
SHAPE OF ICE	Cubelet (Compressed Flake Ice)		
ICE QUALITY	Approx. 90%, Ice (90/70°F, Conductivity 200 µs/cm)		
APPROXIMATE STORAGE CAPACITY	95 lbs.		
ELECTRIC & WATER CONSUMPTION	90/70°F	70/50°F	
ELECTRIC W (kWH/100 lbs.)	1481 (6.3)	1449 (4.3)	
POTABLE WATER gal./24HR (gal./100 lbs.)	68 (12)	96 (12)	
EXTERIOR DIMENSIONS (WxDxH)	34-1/16" x 28-1/2" x 48-1/16" (865 x 723 x 1221 mm)		
EXTERIOR FINISH	Stainless Steel; Galvanized Steel (Rear)		
WEIGHT	Net 375 lbs. (170 kg), Shipping 405 lbs. (184 kg)		
CONNECTIONS - ELECTRIC	Permanent Connection		
- WATER SUPPLY	Inlet 1/2" FPT		
- DRAIN	Drain Pan 3/4" FPT Bin Drain 3/4" FPT		
ICE MAKING SYSTEM	Auger type		
HARVESTING SYSTEM	Direct Driven Auger (1/4 HP Gear Motor)		
ICE MAKING WATER CONTROL	Float Switch		
COOLING WATER CONTROL	N/A		
BIN CONTROL SYSTEM	Mechanical Bin Control (Proximity Sw.)		
COMPRESSOR	Hermetic, Model RS55C1E-PAA		
CONDENSER	Air-cooled, Fin and tube type		
EVAPORATOR	Copper Tube on Cylinder		
REFRIGERANT CONTROL	Thermostatic Expansion Valve		
REFRIGERANT CHARGE	R-404A, 1 lb. 7.1 oz. (660 g)		
DESIGN PRESSURE	High 460 PSIG, Low 290 PSIG		
P.C. BOARD CIRCUIT PROTECTION	High Voltage Cut-off Relay		
COMPRESSOR PROTECTION	Auto-reset Overload Protector		
GEAR MOTOR PROTECTION	Manual reset Circuit Breaker		
REFRIGERANT CIRCUIT PROTECTION	Auto-reset High Pressure Control Switch		
LOW WATER PROTECTION	Float Switch and Timer		
ACCESSORIES - SUPPLIED	Spare Fuse		
- REQUIRED	Legs		
OPERATING CONDITIONS	VOLTAGE RANGE	104 - 127 V	
	AMBIENT TEMP.	45 - 100° F	
	WATER SUPPLY TEMP.	45 - 90° F	
	WATER SUPPLY PRESSURE	10 - 113 PSIG	
DRAWING NO. (DIMENSIONS)	340969---		

We reserve the right to make changes in specifications and design without prior notice.

4. DCM-750BWF (Water-cooled)

AC SUPPLY VOLTAGE	115/60/1		
COMPRESSOR	120 V	10 RLA	60 LRA
GEAR MOTOR	120 V	3 FLA	1/4 HP
AGITATING MOTOR	120 V	1.8 FLA (Total)	110 W
DISPENSING MOTOR	120 V	0.9 FLA	55 W
OTHER	120 V	0.6 A	
MAXIMUM FUSE SIZE	20 A		
MAX. HACR BREAKER (USA ONLY)	20 A		
MAX. CIRC. BREAKER (CANADA ONLY)	20 A		
MINIMUM CIRCUIT AMPACITY	20 A		
APPROXIMATE ICE PRODUCTION PER 24 HR.	Ambient Temp.(°F)	WATER TEMP. (°F)	
lbs./day (kg/day)		50	70
Reference without *marks	70	* 879 (399)	851 (386)
	80	809 (367)	789 (358)
	90	751 (341)	* 746 (338)
	100	697 (316)	* 628 (285)
SHAPE OF ICE	Cubelet (Compressed Flake Ice)		
ICE QUALITY	Approx. 90%, Ice (90/70°F, Conductivity 200 µs/cm)		
APPROXIMATE STORAGE CAPACITY	95 lbs.		
ELECTRIC & WATER CONSUMPTION	90/70°F	70/50°F	
ELECTRIC W (kWH/100 lbs.)	1349 (4.3)	1348 (3.7)	
POTABLE WATER	89 (12)	105 (12)	
WATER - COOLED CONDENSER	624 (83.7)	421 (47.9)	
gal./24HR (gal./100 lbs.)			
EXTERIOR DIMENSIONS (WxDxH)	34-1/16" x 28-1/2" x 48-1/16" (865 x 723 x 1221 mm)		
EXTERIOR FINISH	Stainless Steel; Galvanized Steel (Rear)		
WEIGHT	Net 375 lbs. (170 kg), Shipping 405 lbs. (184 kg)		
CONNECTIONS - ELECTRIC	Permanent Connection		
- WATER SUPPLY	Inlet 1/2" FPT	Condenser Inlet	1/2" FPT
- DRAIN	Drain Pan 3/4" FPT	Condenser Outlet	1/2" FPT
	Bin Drain 3/4" FPT		
ICE MAKING SYSTEM	Auger type		
HARVESTING SYSTEM	Direct Driven Auger (1/4 HP Gear Motor)		
ICE MAKING WATER CONTROL	Float Switch		
COOLING WATER CONTROL	Water Regulating Valve		
BIN CONTROL SYSTEM	Mechanical Bin Control (Proximity Sw.)		
COMPRESSOR	Hermetic, Model RS55C1E-PAA		
CONDENSER	Water-cooled, Double tube type		
EVAPORATOR	Copper Tube on Cylinder		
REFRIGERANT CONTROL	Thermostatic Expansion Valve		
REFRIGERANT CHARGE	R-404A, 1 lb. 1.7 oz. (500 g)		
DESIGN PRESSURE	High 460 PSIG, Low 290 PSIG		
P.C. BOARD CIRCUIT PROTECTION	High Voltage Cut-off Relay		
COMPRESSOR PROTECTION	Auto-reset Overload Protector		
GEAR MOTOR PROTECTION	Manual reset Circuit Breaker		
REFRIGERANT CIRCUIT PROTECTION	Auto-reset High Pressure Control Switch		
LOW WATER PROTECTION	Float Switch and Timer		
ACCESSORIES - SUPPLIED	Spare Fuse		
- REQUIRED	Legs		
OPERATING CONDITIONS	VOLTAGE RANGE	104 - 127 V	
	AMBIENT TEMP.	45 - 100° F	
	WATER SUPPLY TEMP.	45 - 90° F	
	WATER SUPPLY PRESSURE	10 - 113 PSIG	
DRAWING NO. (DIMENSIONS)	340970---		

We reserve the right to make changes in specifications and design without prior notice.

II. GENERAL INFORMATION

1. CONSTRUCTION

DCM-500BAF, DCM-750BAF

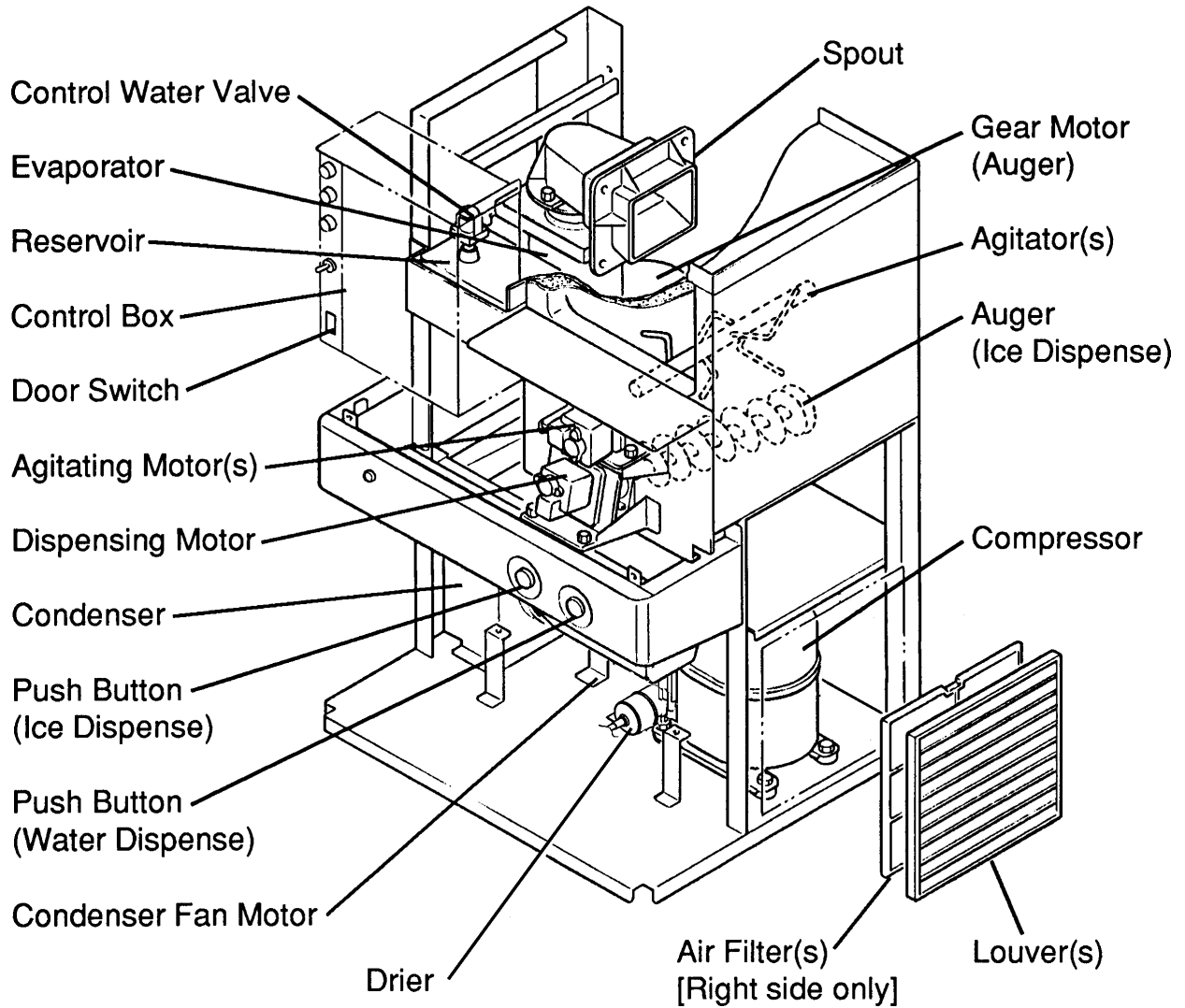

DCM-500BWF, DCM-750BWF

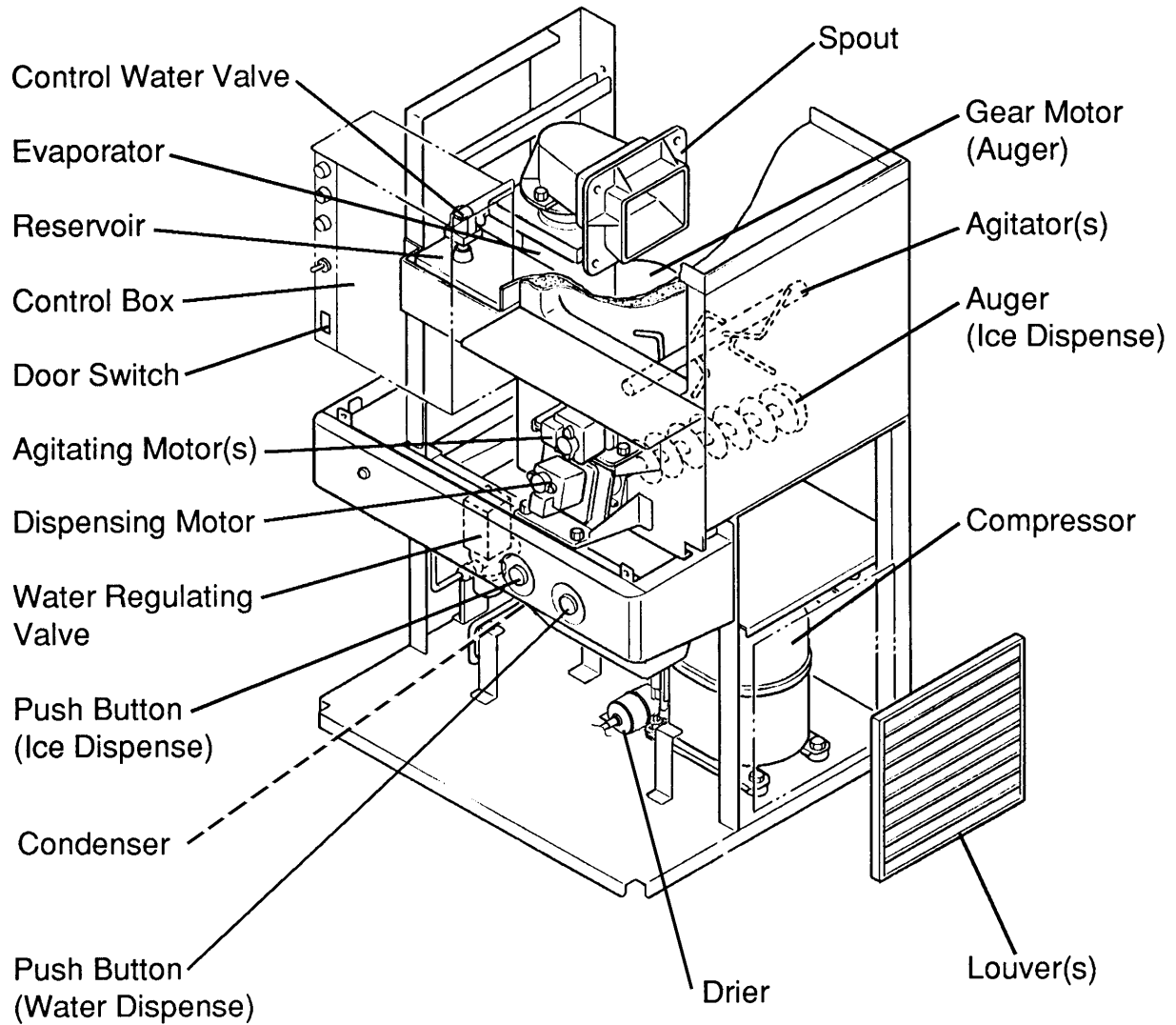

2. CONTROL BOX LAYOUT

DCM-500BAF, DCM-500BWF

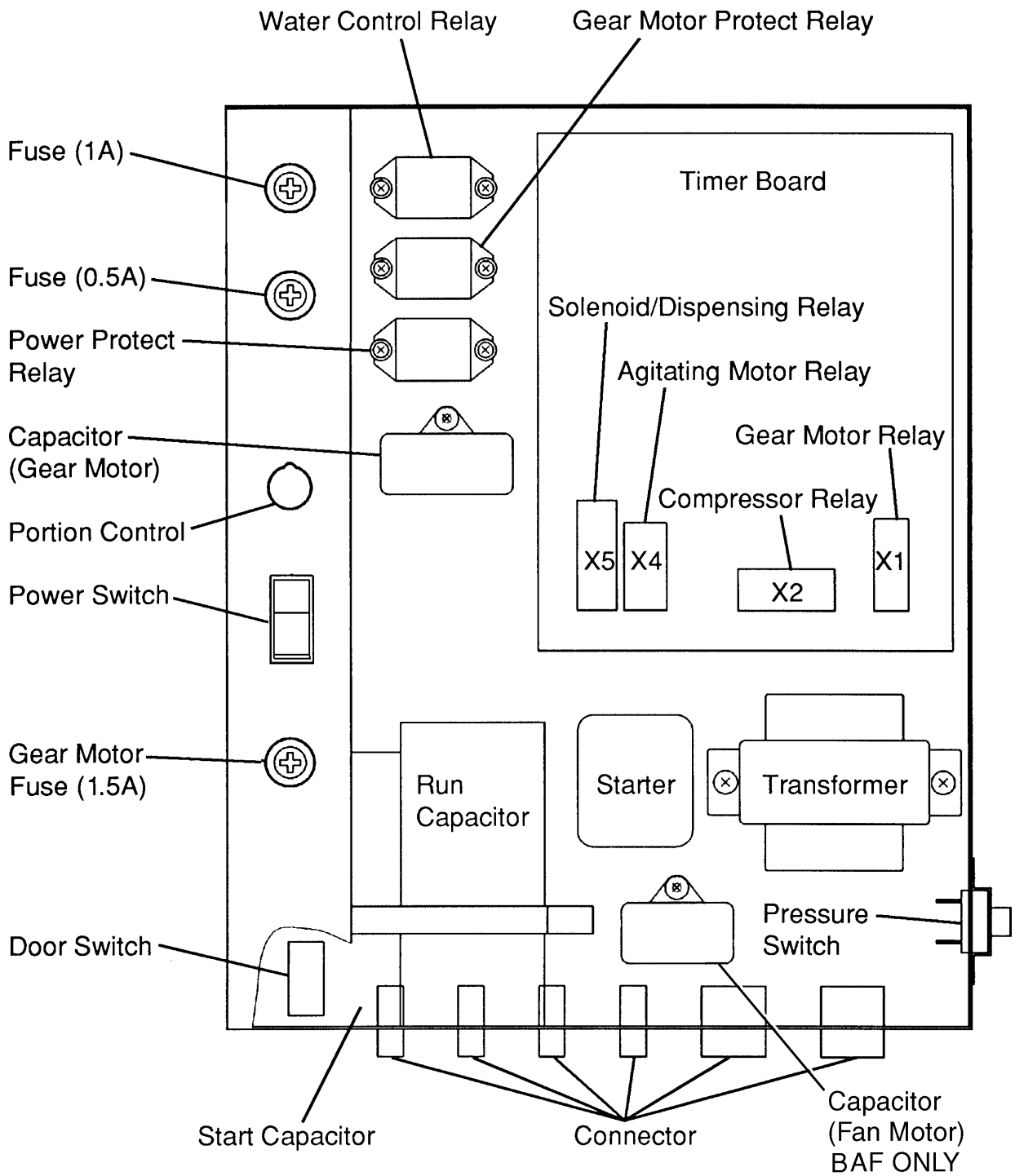

DCM-750BAF, DCM-750BWF

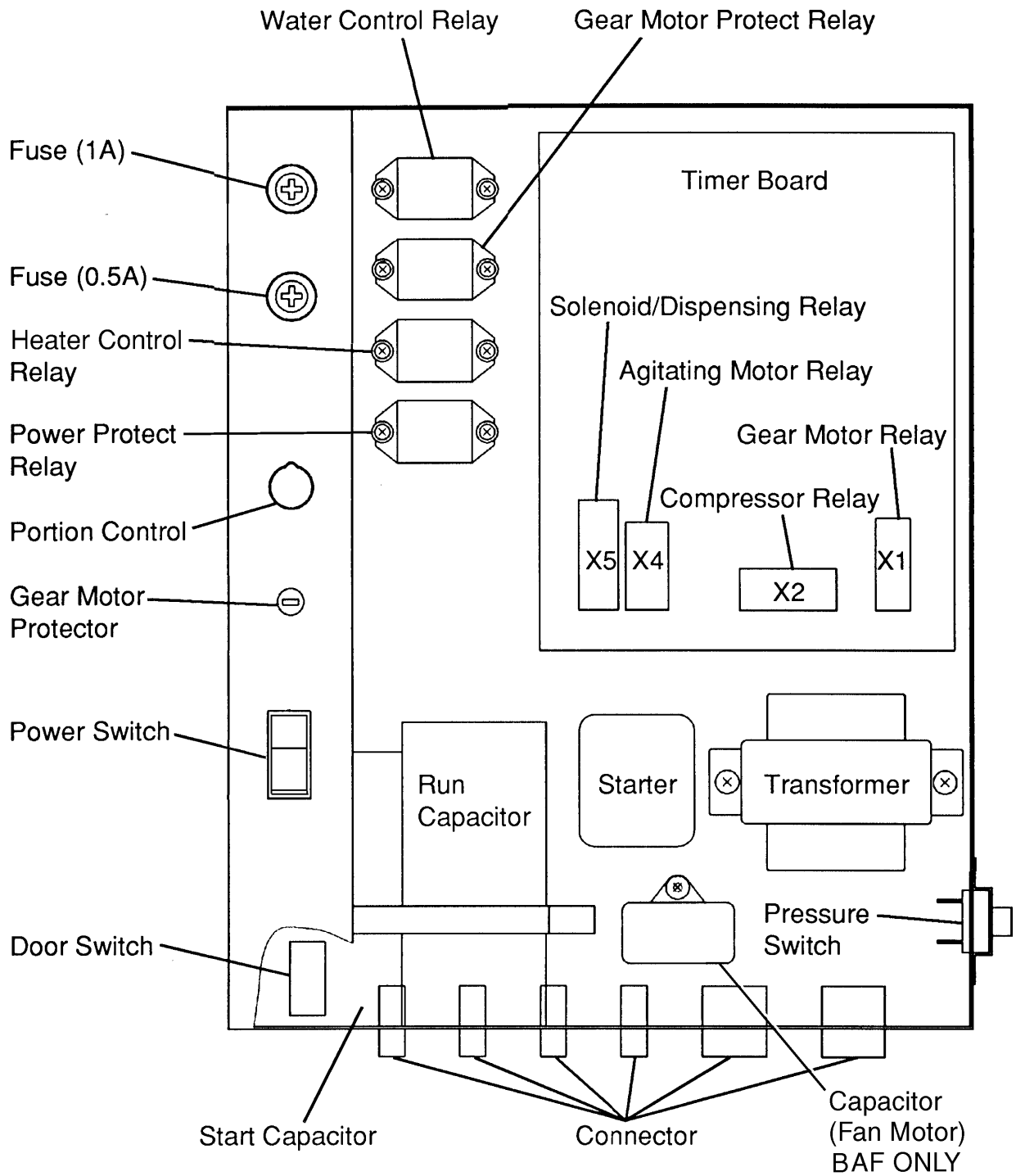

5. CABINET STAND

When placing the ice dispenser on the Cabinet Stand:

- 1) Attach four adjustable legs to the Cabinet Stand. (Cabinet Stand accessory)
- 2) Remove the protective plastic film from the panels.
- 3) Remove the Front Panel by lifting up and pulling toward you.
- 4) Place the ice dispenser on the Cabinet Stand.

Combination: SD-450 DCM-500BAF, BWF
SD-700 DCM-750BAF, BWF

- 5) You must secure the ice dispenser to the Cabinet Stand with four bolts (Cabinet Stand accessory).
6. Seal the seam all around between the dispenser and the Cabinet Stand with food grade silicone. See Fig. 1
- 7) Replace the Front Panel.

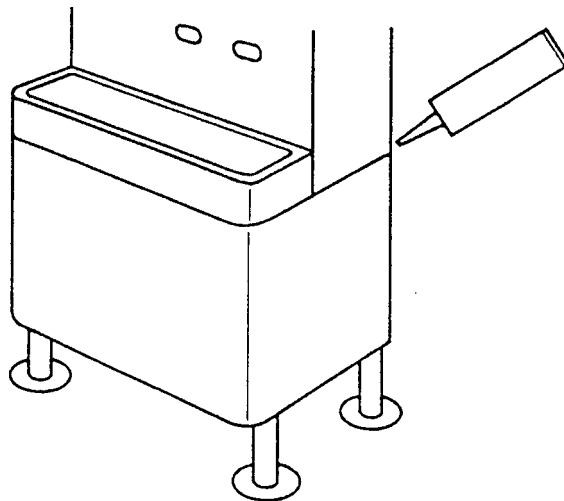

Fig. 1

DIMENSIONS WITH DCM-500BAF ON SD-450

Unit: inch (mm.)

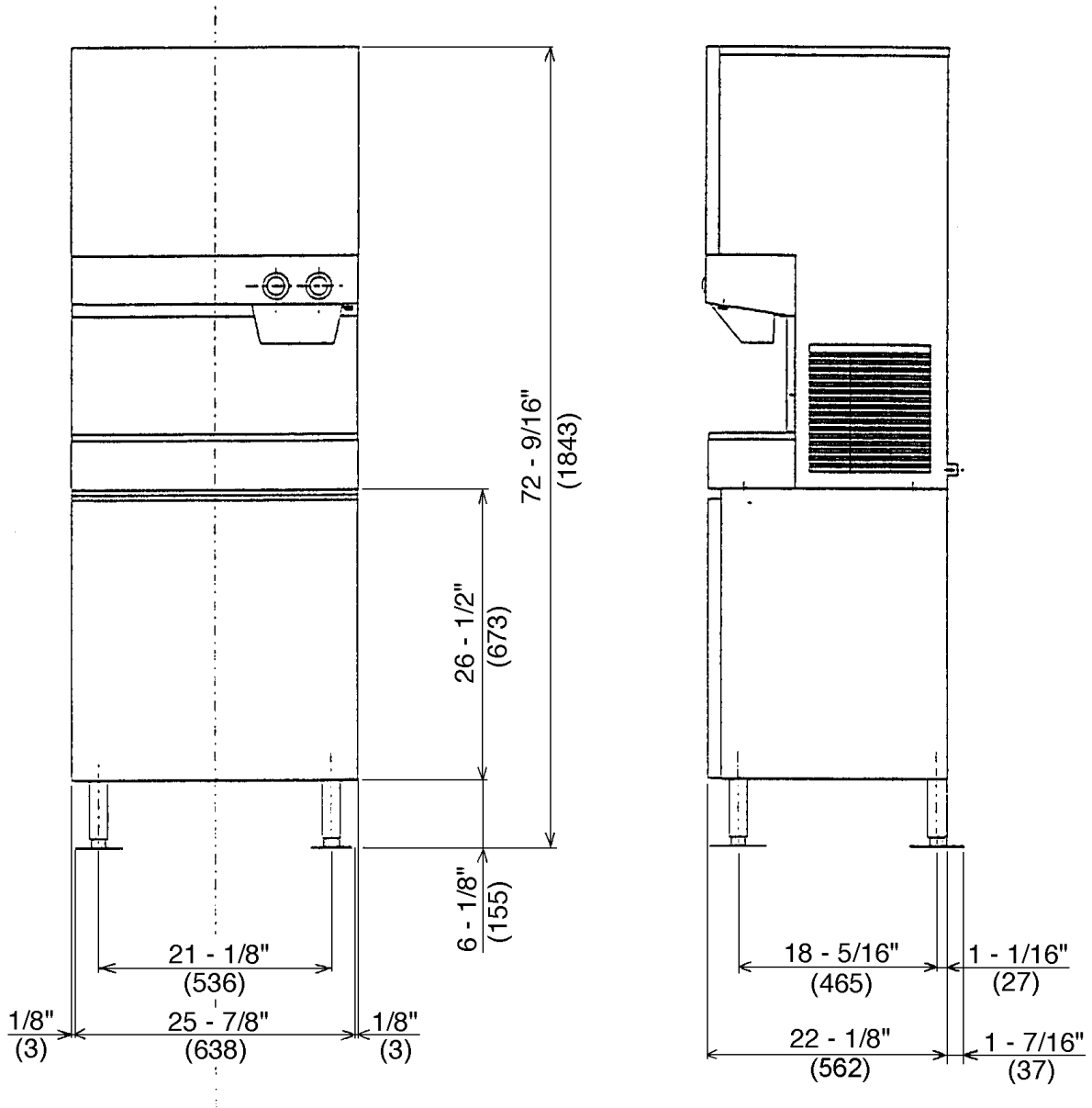

Fig. 2

DIMENSIONS WITH DCM-750BAF ON SD-700

Unit: inch (mm.)

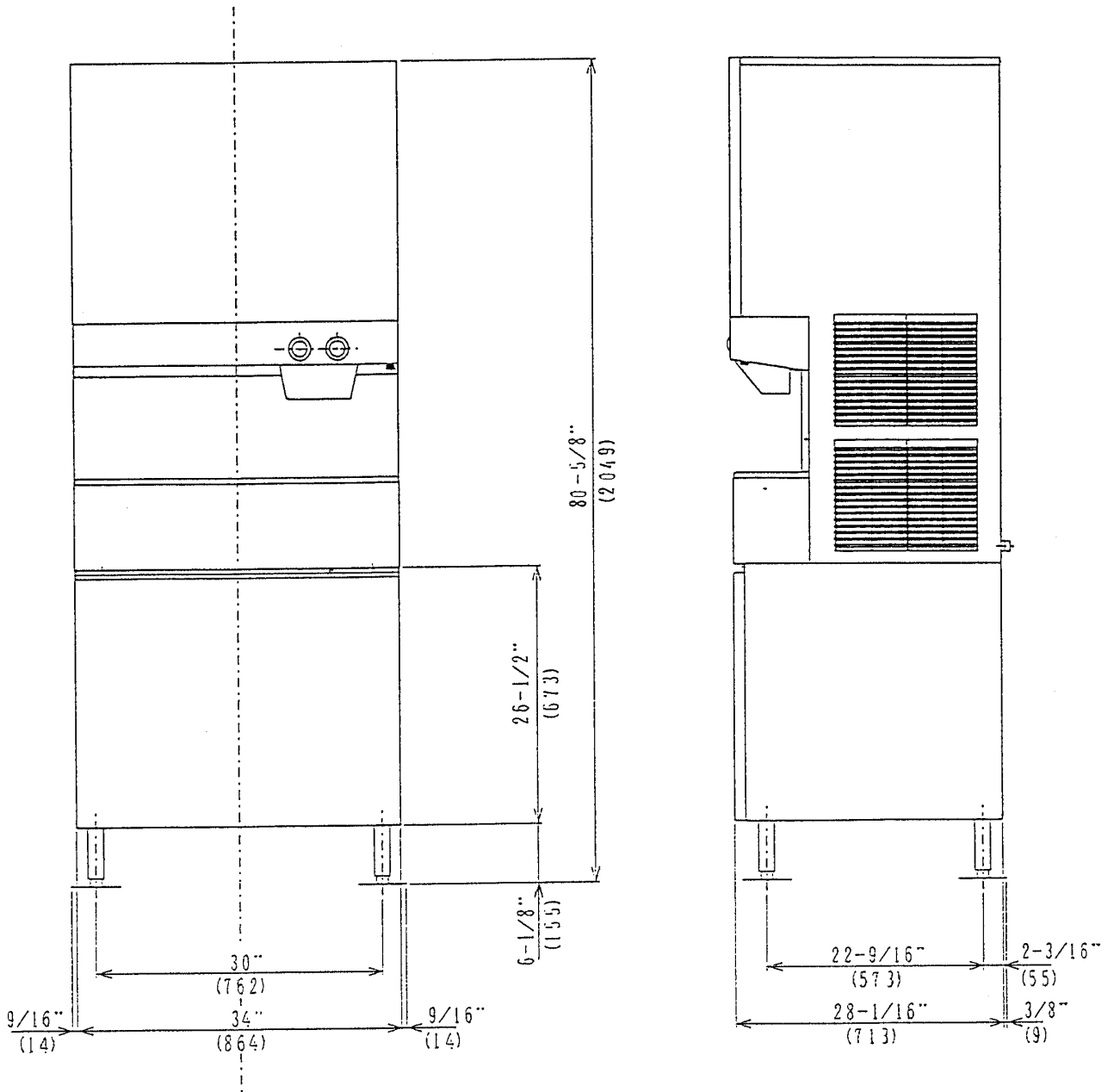
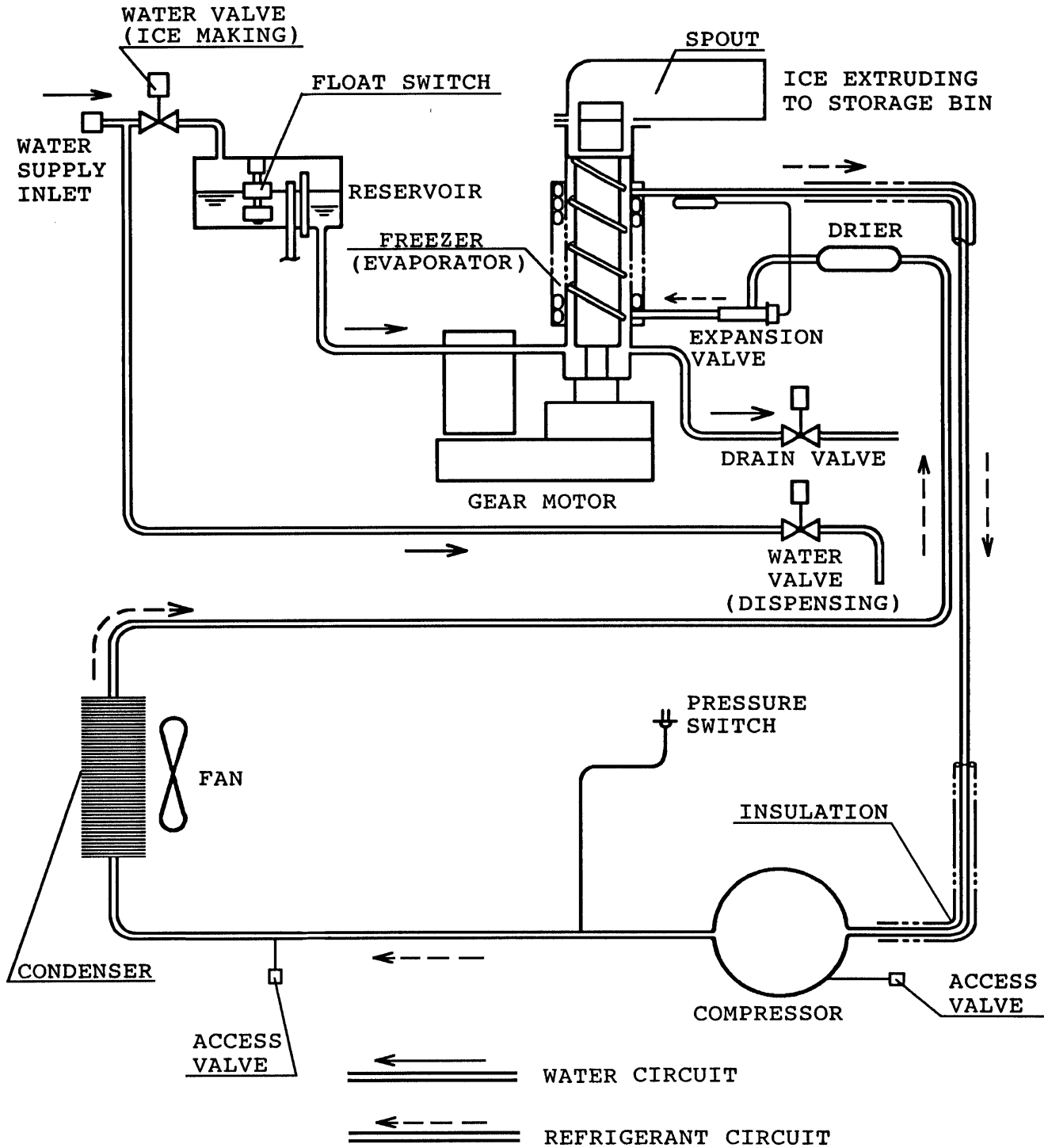

Fig. 3

III. TECHNICAL INFORMATION

1. WATER CIRCUIT AND REFRIGERANT CIRCUIT

DCM-500BAF



DCM-500BWF

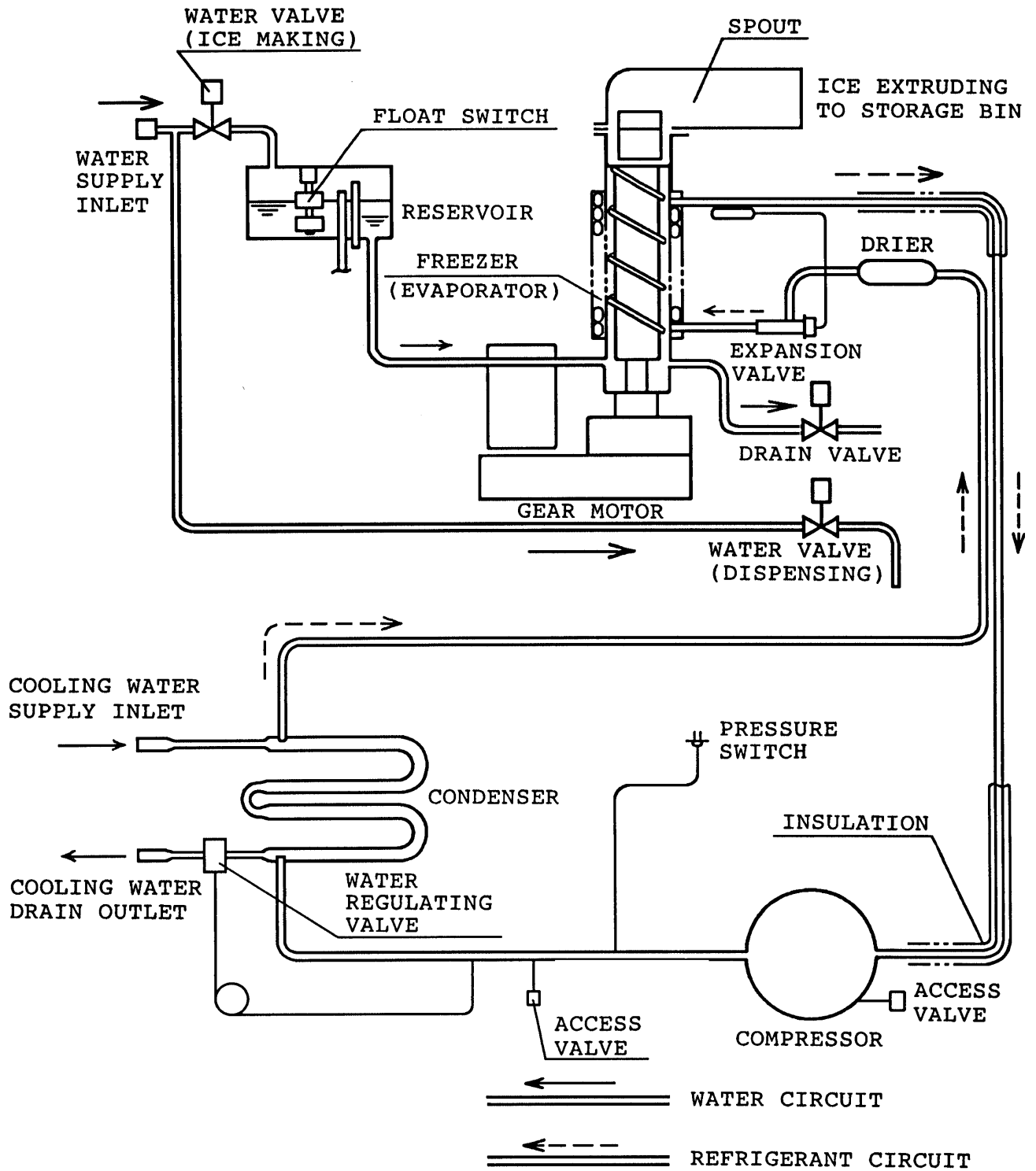

DCM-750BAF

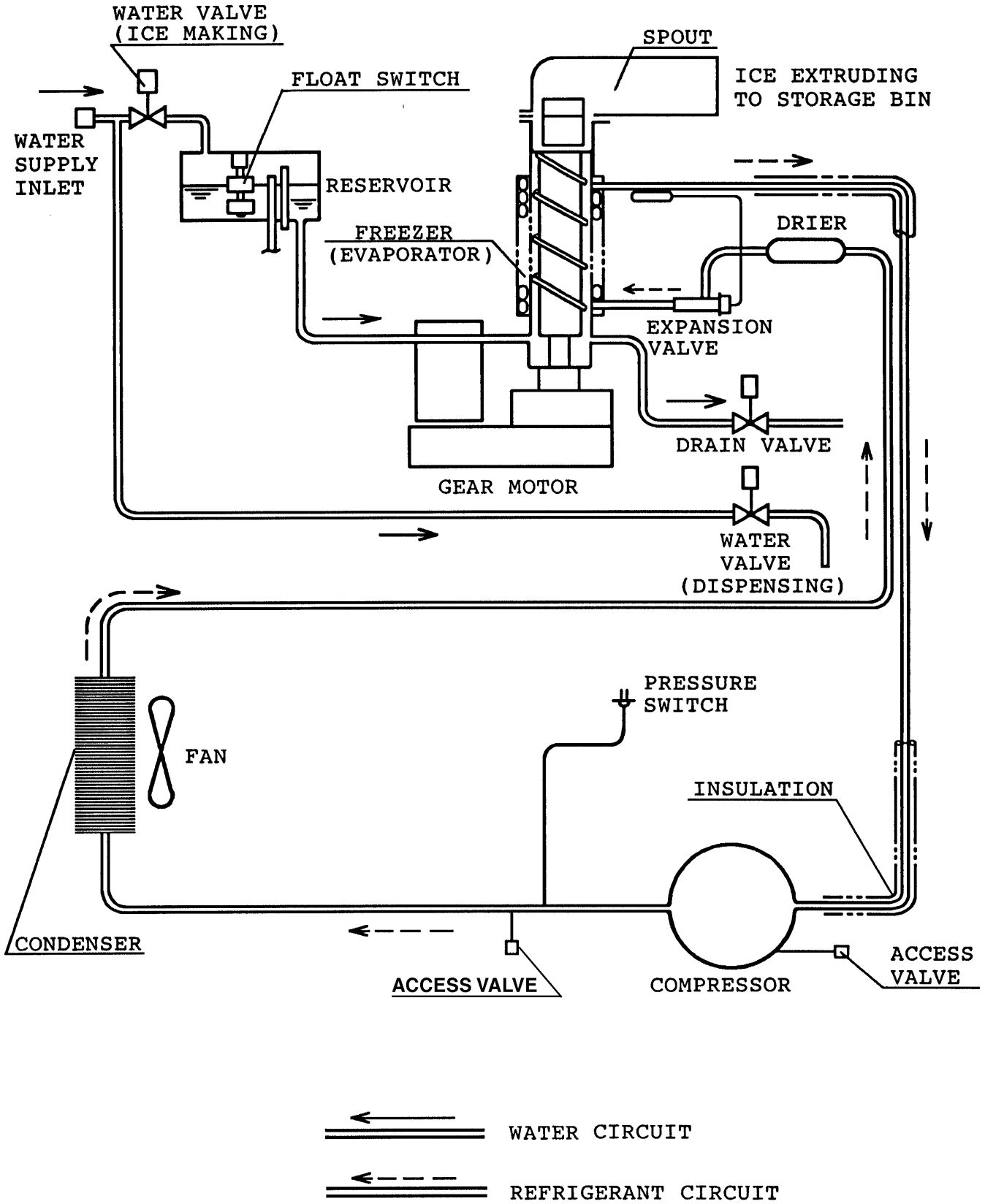

DCM-750BWF

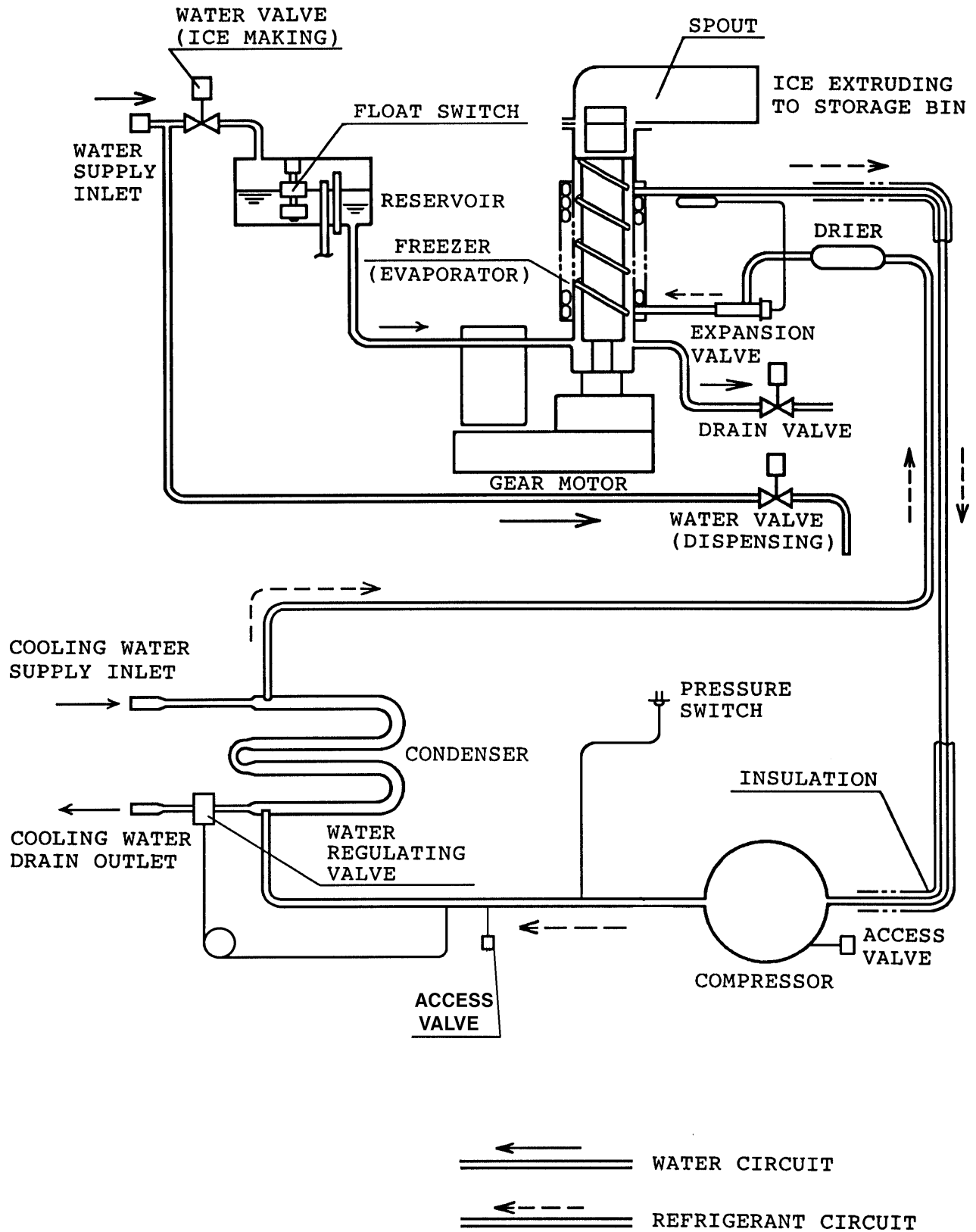

2. WIRING DIAGRAM

DCM-500BAF, DCM-500BWF

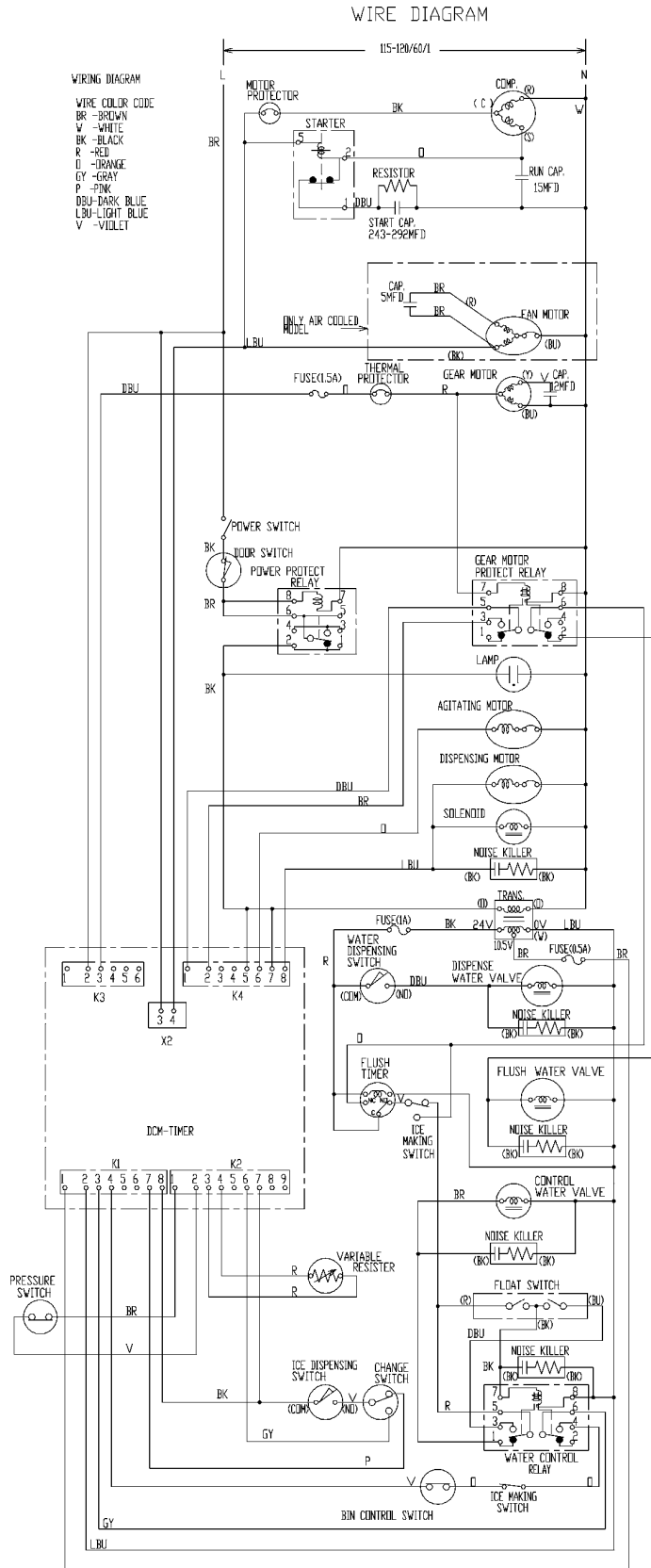

DCM-750BAF, DCM-750BWF

WIRING DIAGRAM
WIRE COLOR CODE
BR - BROWN
W - WHITE
BK - BLACK
RD - RED
OR - ORANGE
GY - GRAY
PK - PINK
V - VIOLET
DBU - DARK BLUE
LBU - LIGHT BLUE

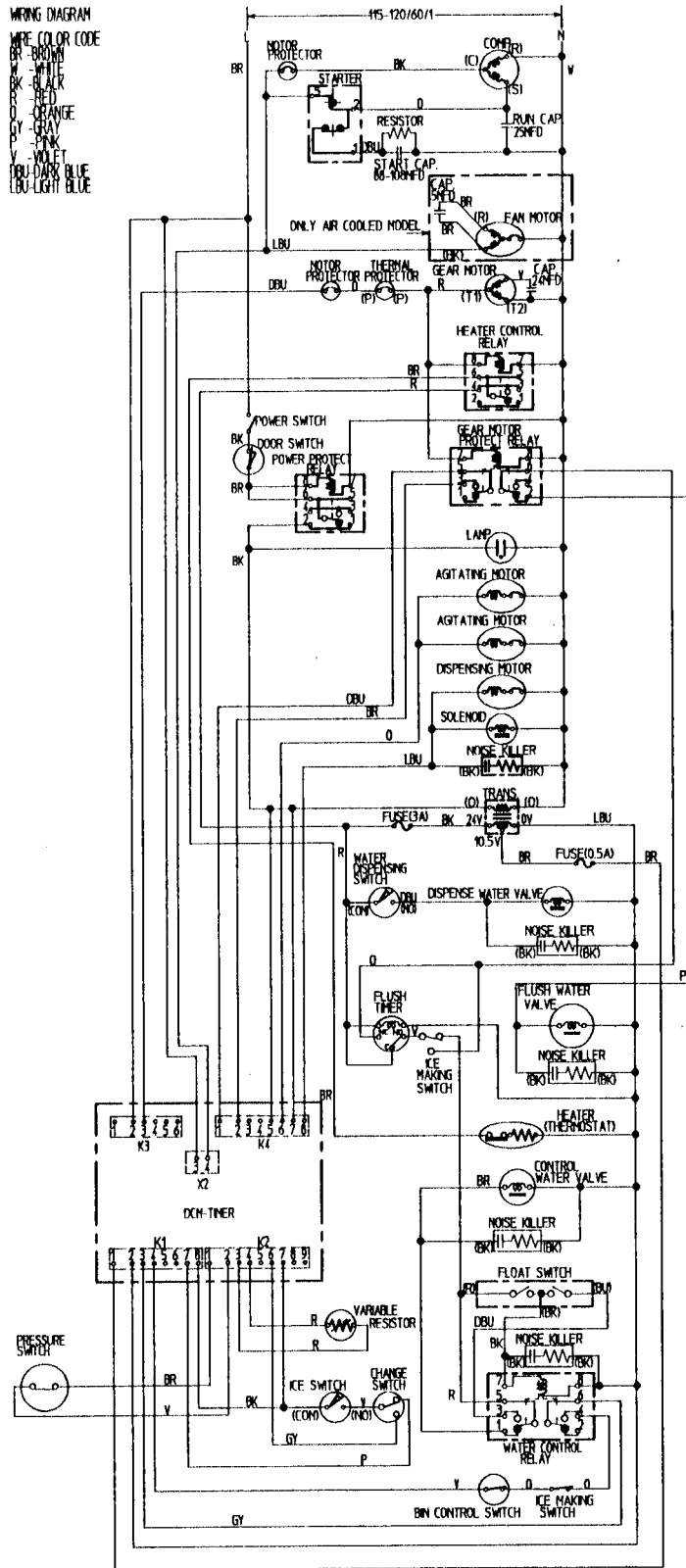

3. SEQUENCE OF ELECTRICAL CIRCUIT

[a] When Power Switch and ICE MAKING SWITCH are moved to "ON" position, water starts to be supplied to Reservoir.

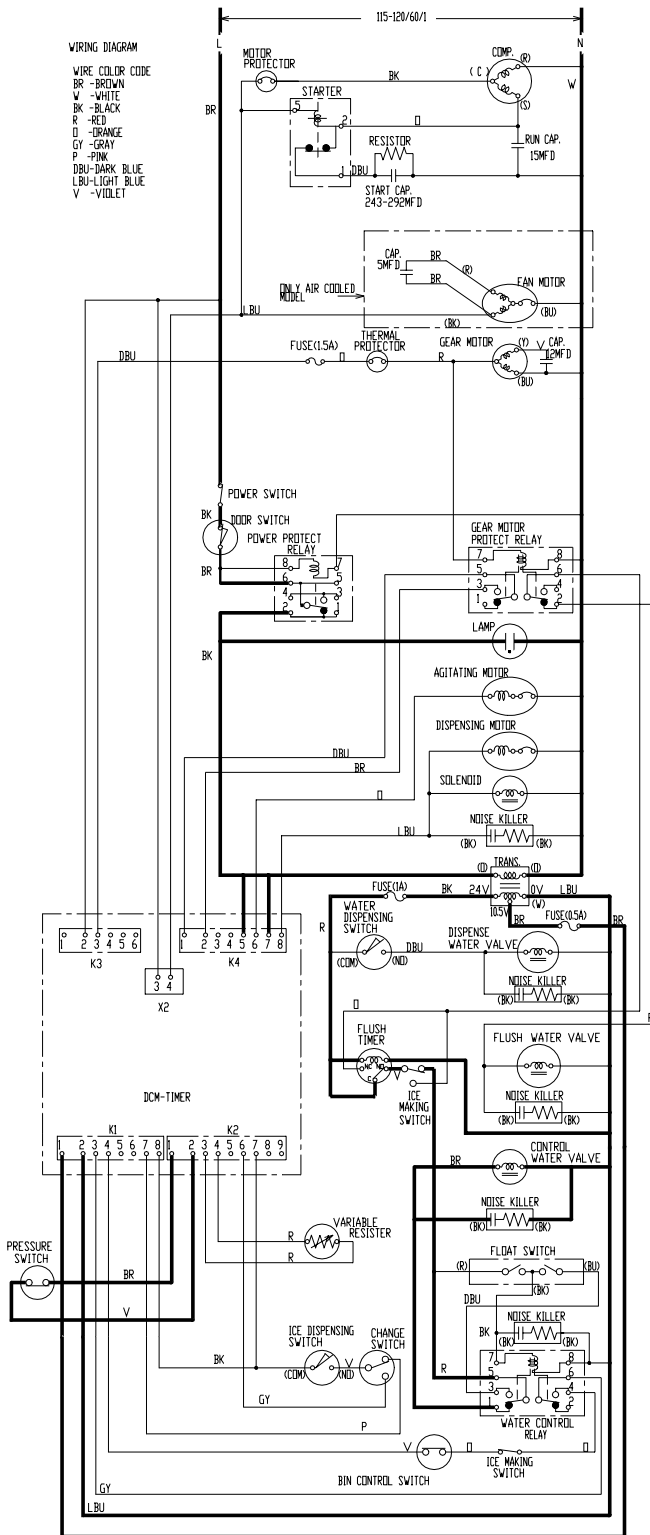

[DCM-500]

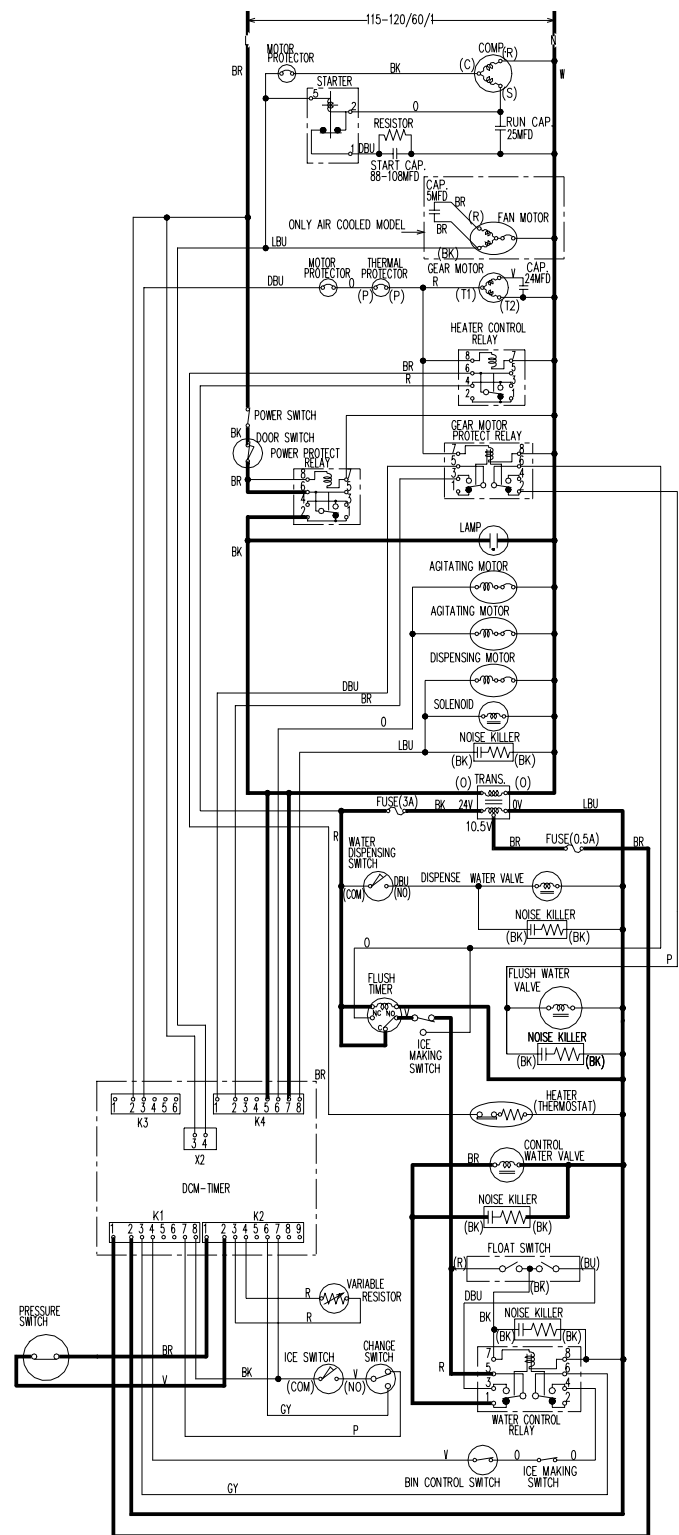

[DCM-750]

[b1] When Reservoir has been filled up, Gear Motor starts immediately. (Reservoir filled)

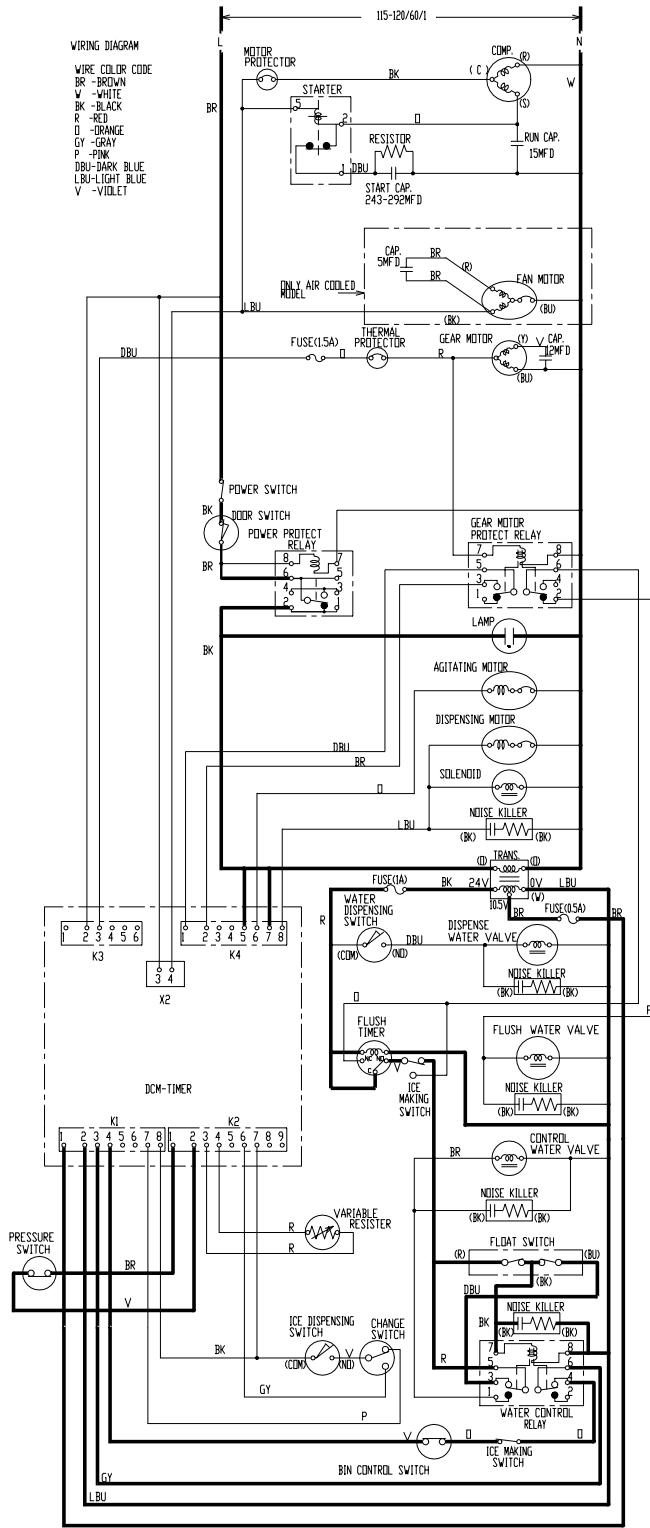

[DCM-500]

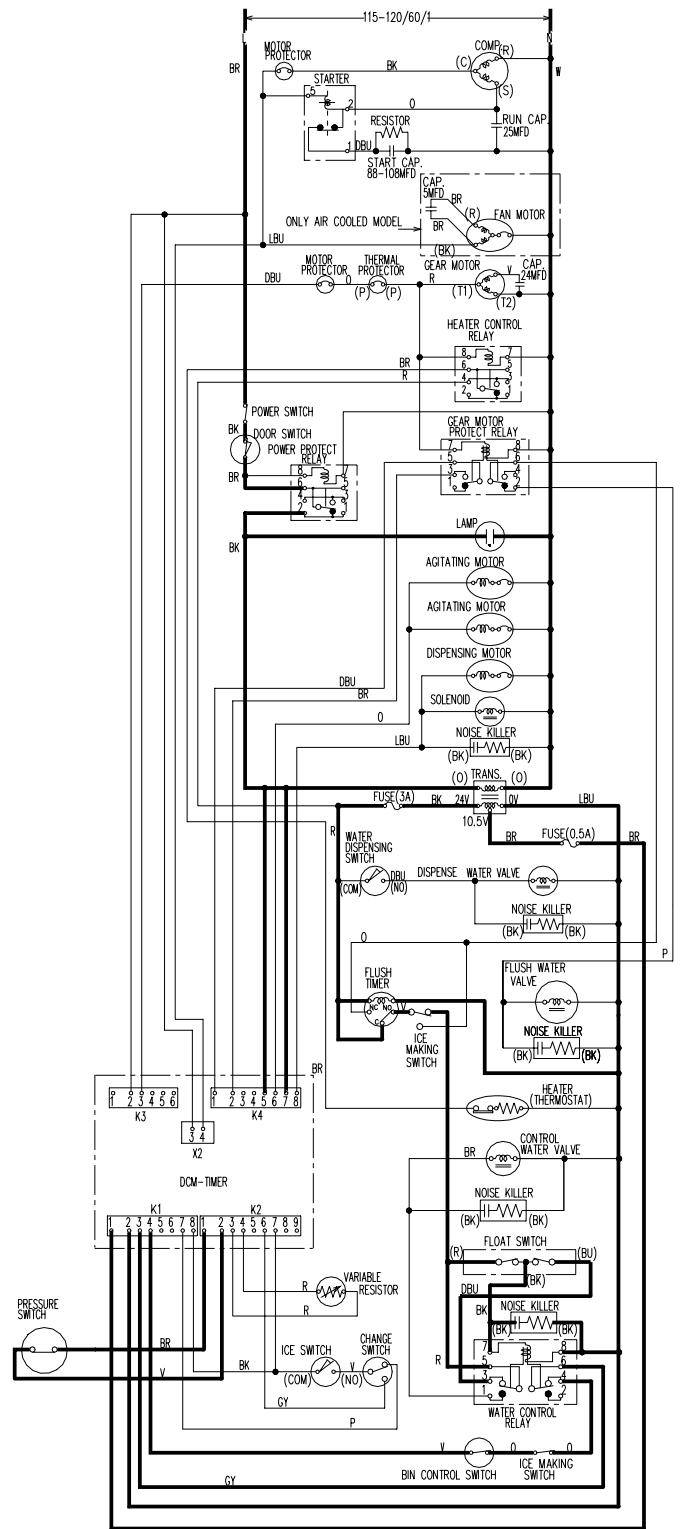

[DCM-750]

[b2] When Reservoir has been filled up, Gear Motor starts immediately. (Gear Motor starts)

WIRING DIAGRAM
 WIRE COLOR CODE
 BR - BROWN
 W - WHITE
 BK - BLACK
 R - RED
 O - ORANGE
 GY - GRAY
 P - PINK
 DBU - DARK BLUE
 LBU - LIGHT BLUE
 V - VIOLET

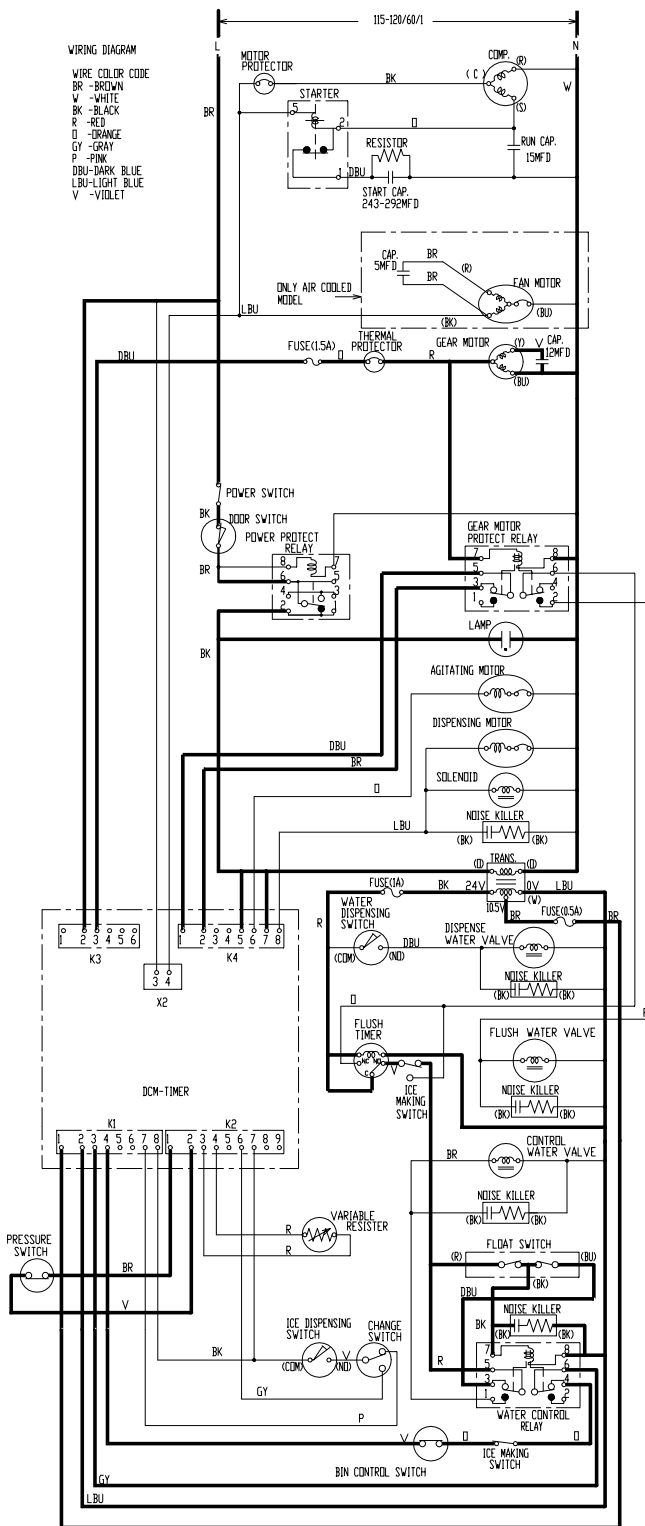

[DCM-500]

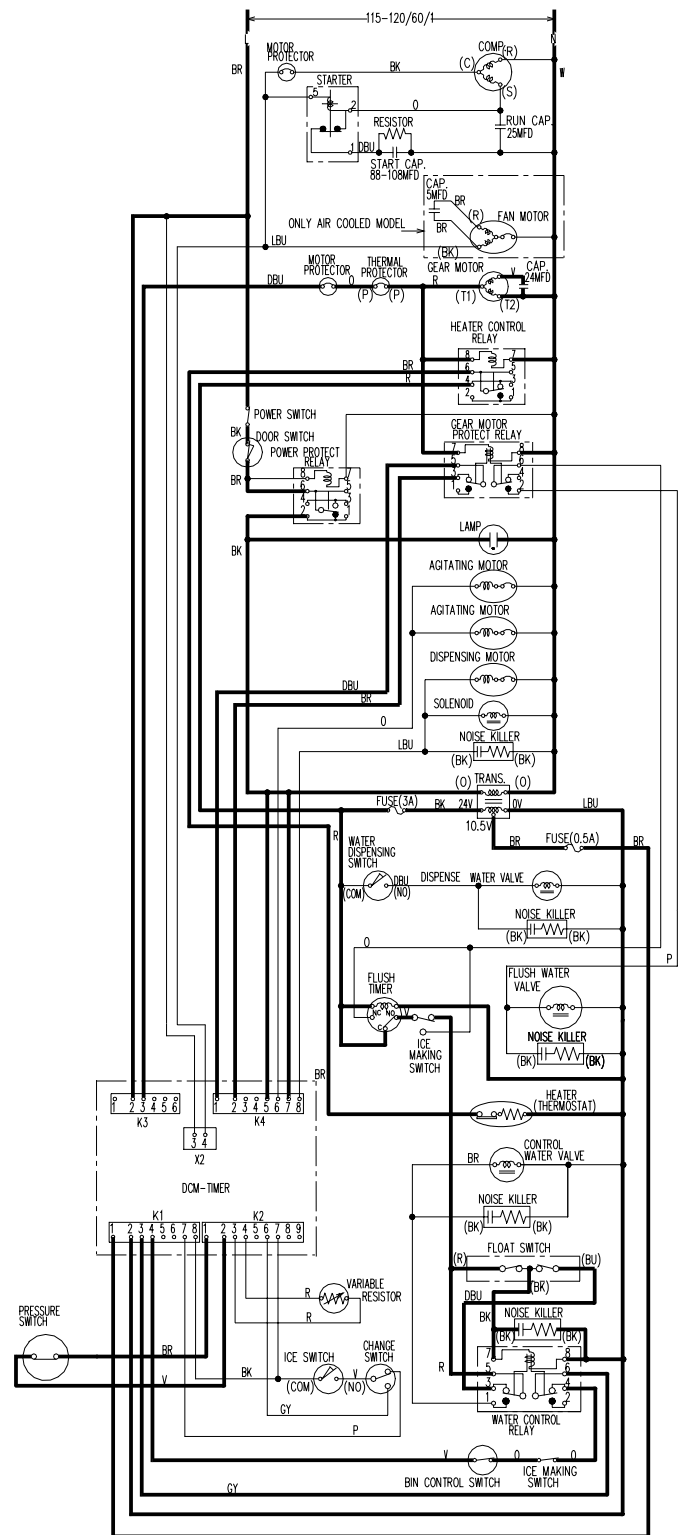

[DCM-750]

[d] Bin Control tripped. Compressor stops about 90 sec. later. Agitating Motor operates for about 0.6 sec.

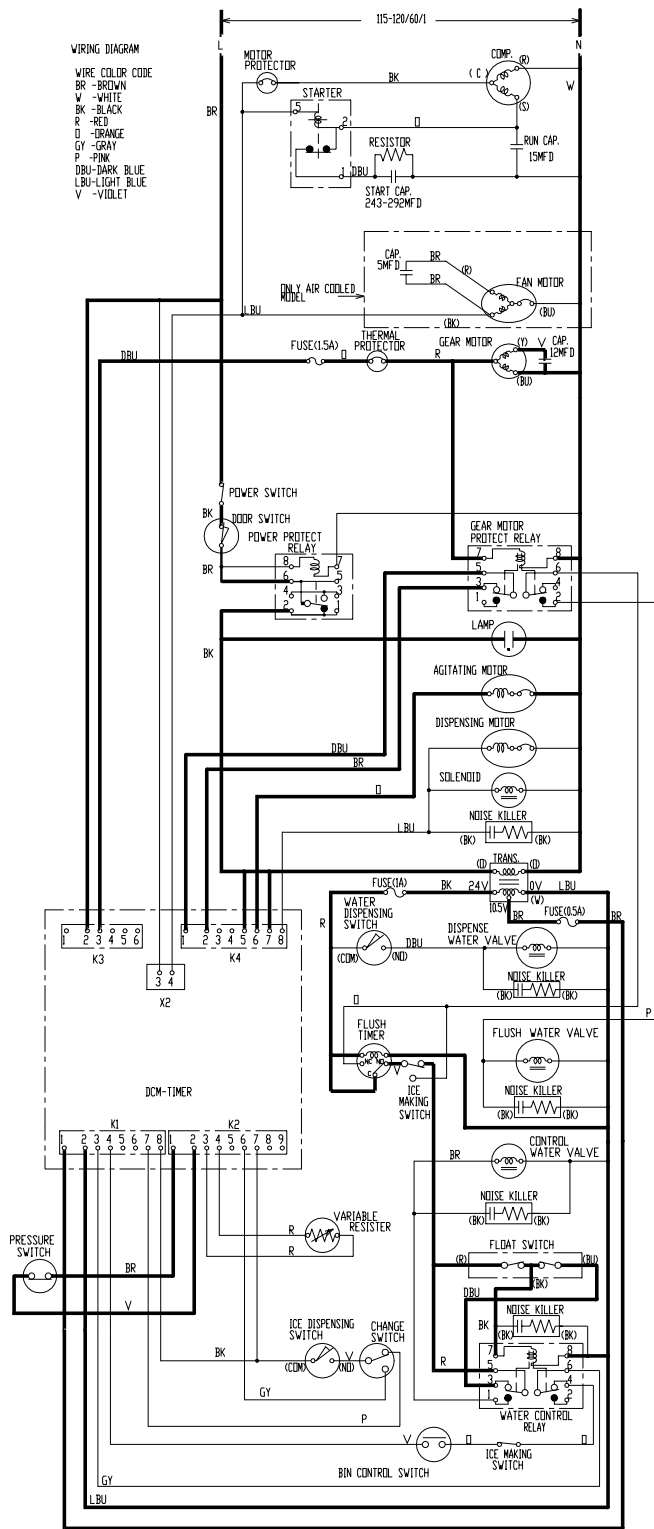

[DCM-500]

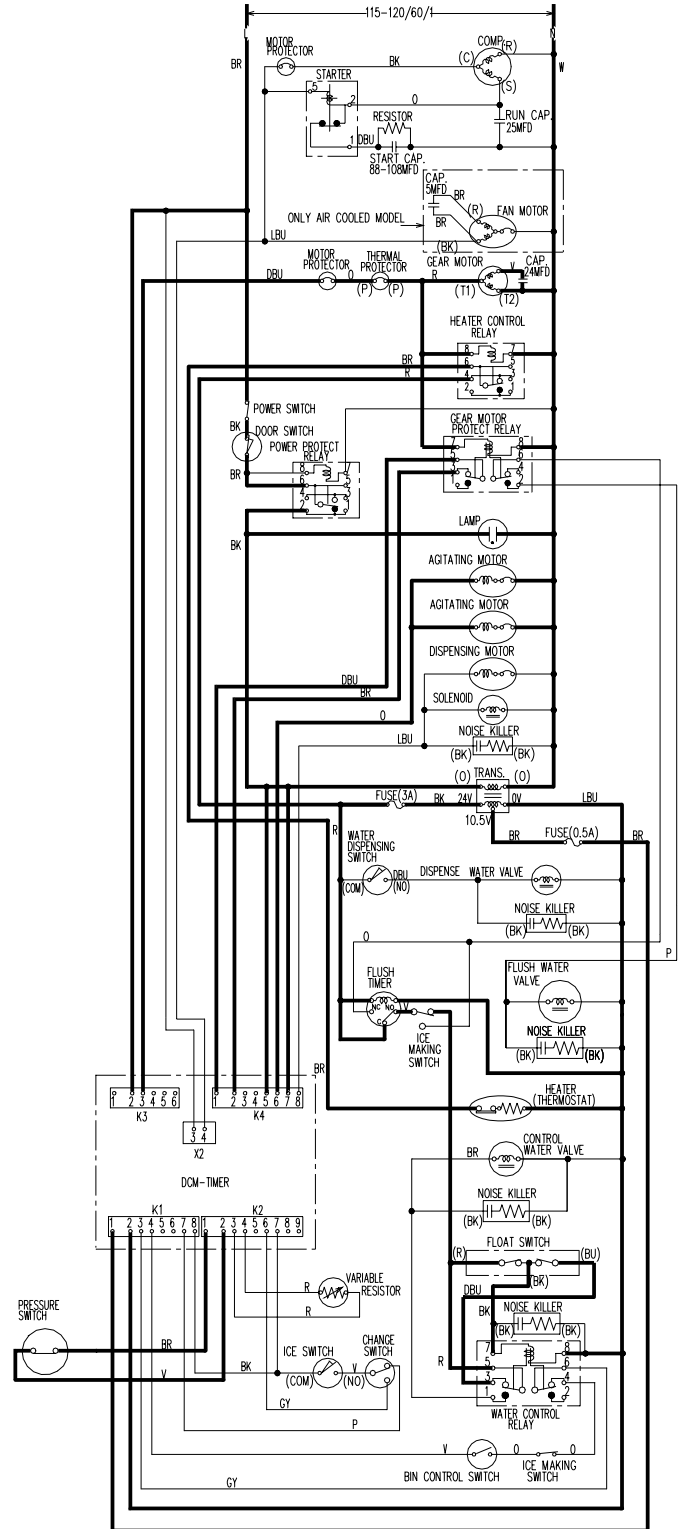

[DCM-750]

[e] Gear Motor stops about 60 sec. after Compressor stops

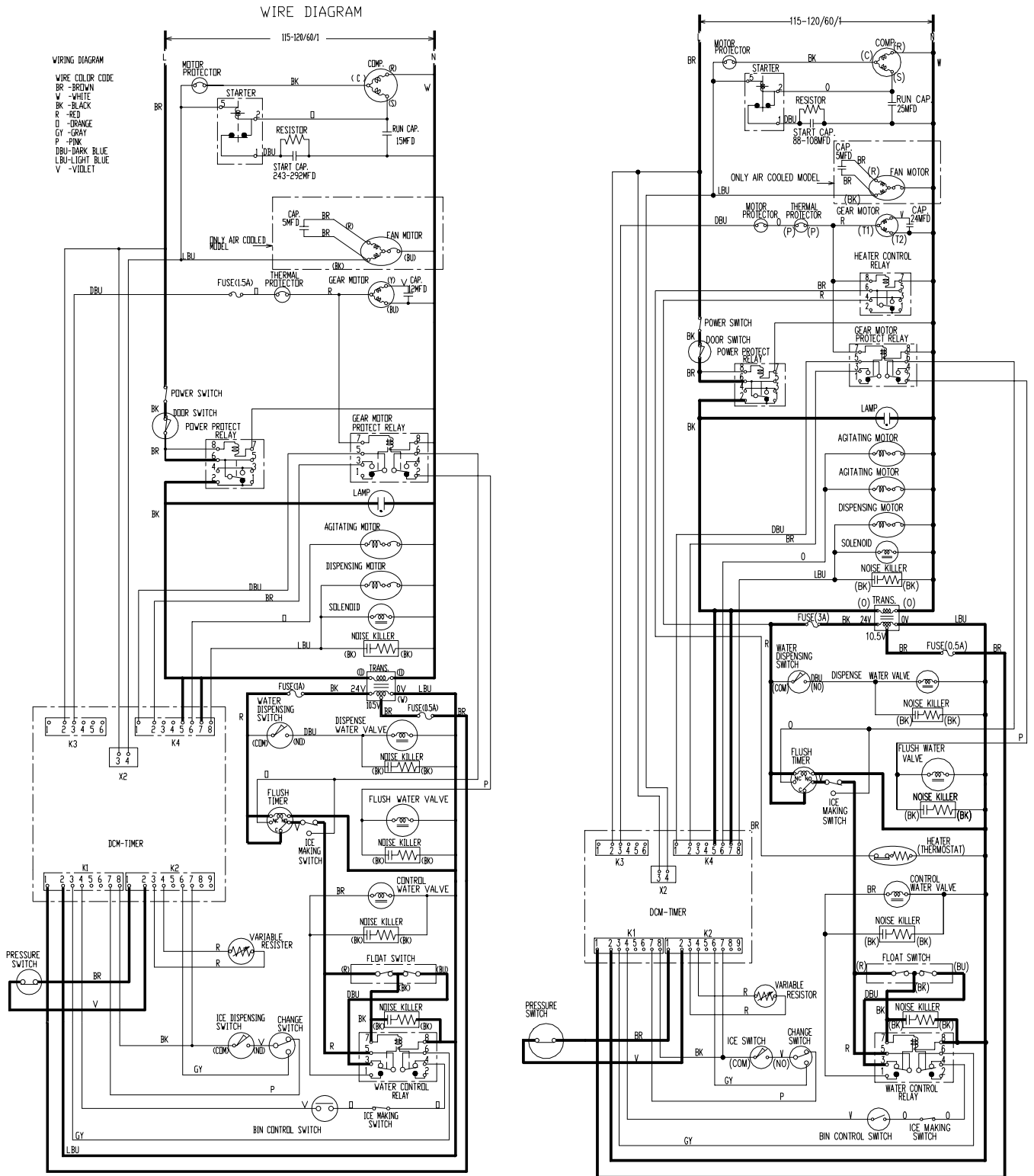

CONTINUOUS DISPENSING

[f1] Dispensing ice. (Bin Control still tripped) (Agitating Motor operates for 0.6 sec. every 12 sec.)

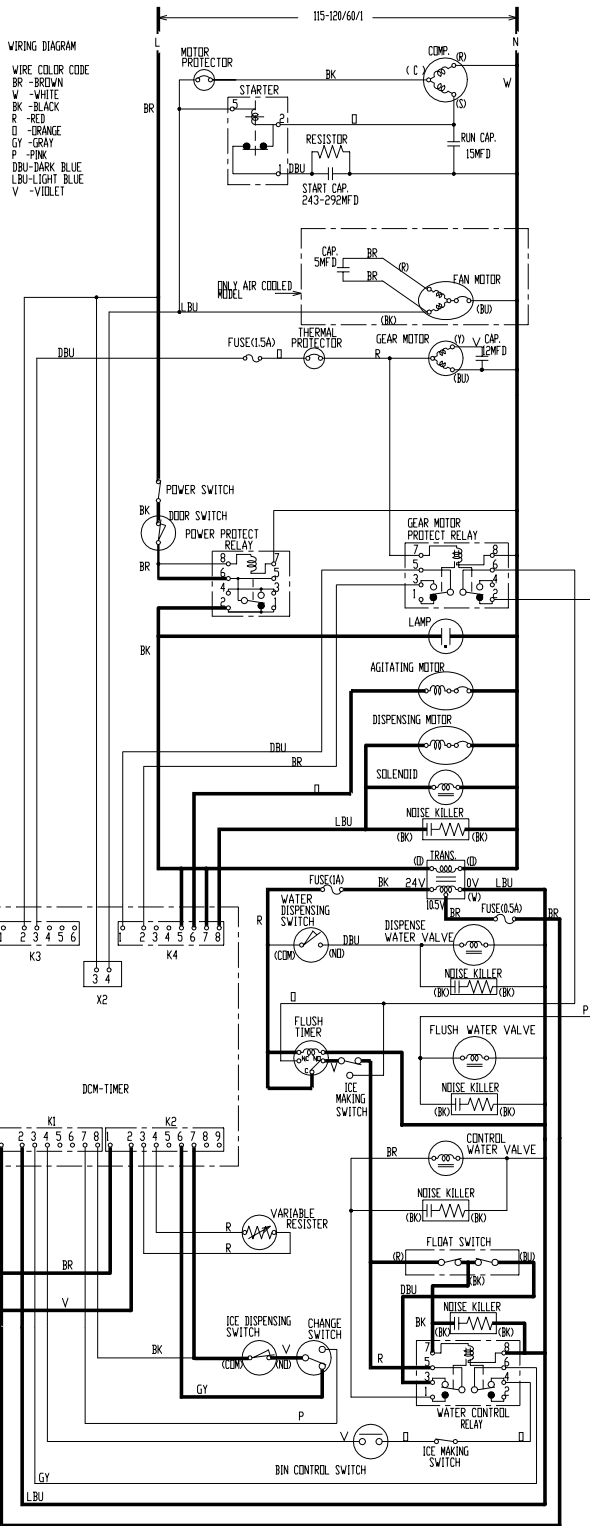

[DCM-500]

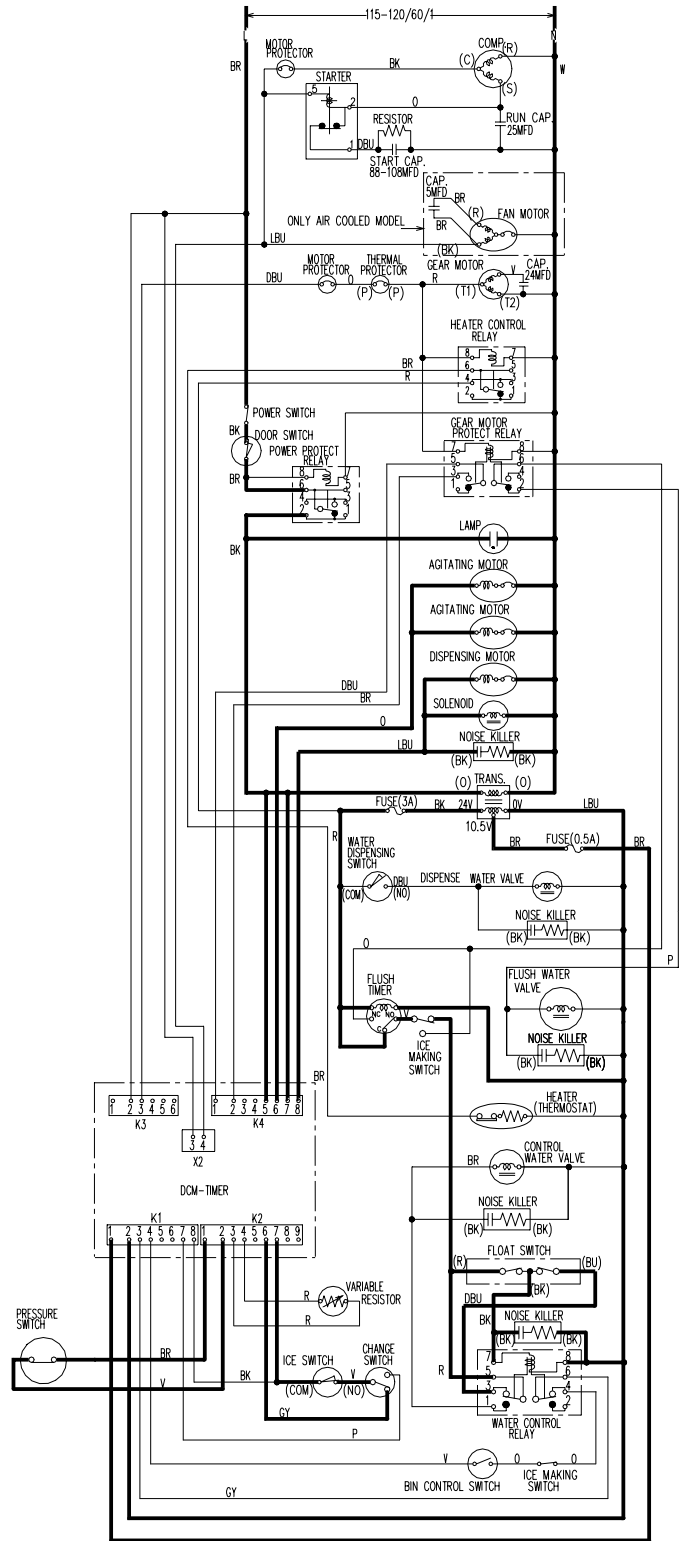

[DCM-750]

PORTION CONTROL DISPENSING

[f2] Agitating Motor operates for 0.6 sec. when Ice Dispensing Button is pushed, after a 12 sec. delay. Agitating Motor operates for 0.6 sec., and then 0.6 sec. every 12 sec.

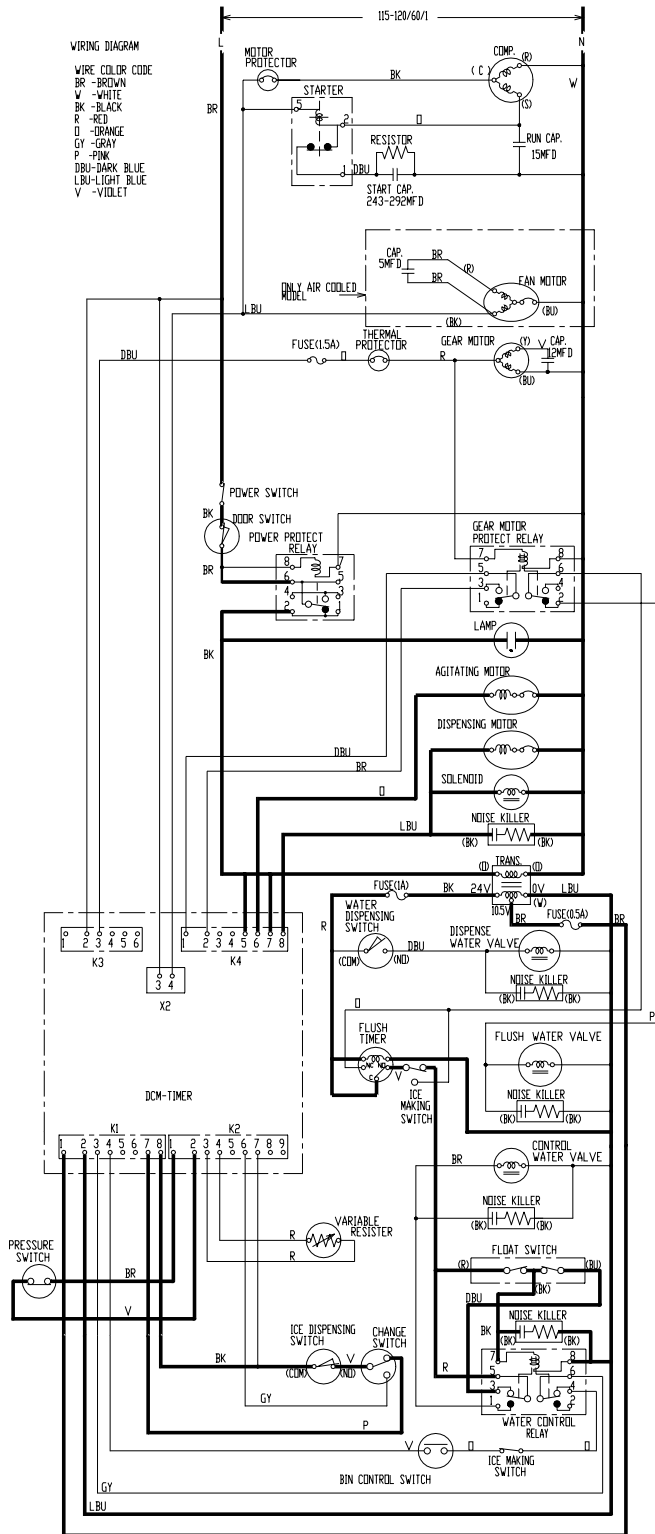

[DCM-500]

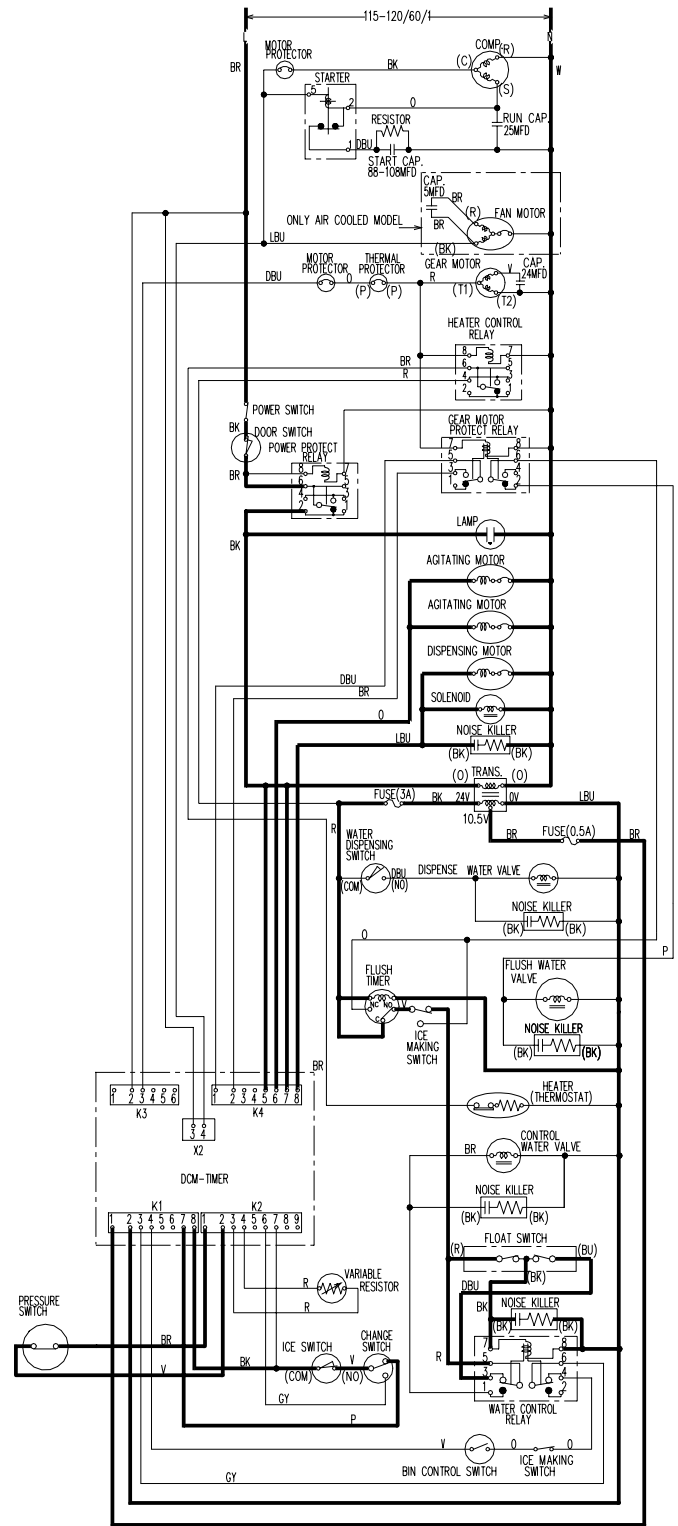

[DCM-750]

[g] Dispensing water. (Bin Control still tripped).

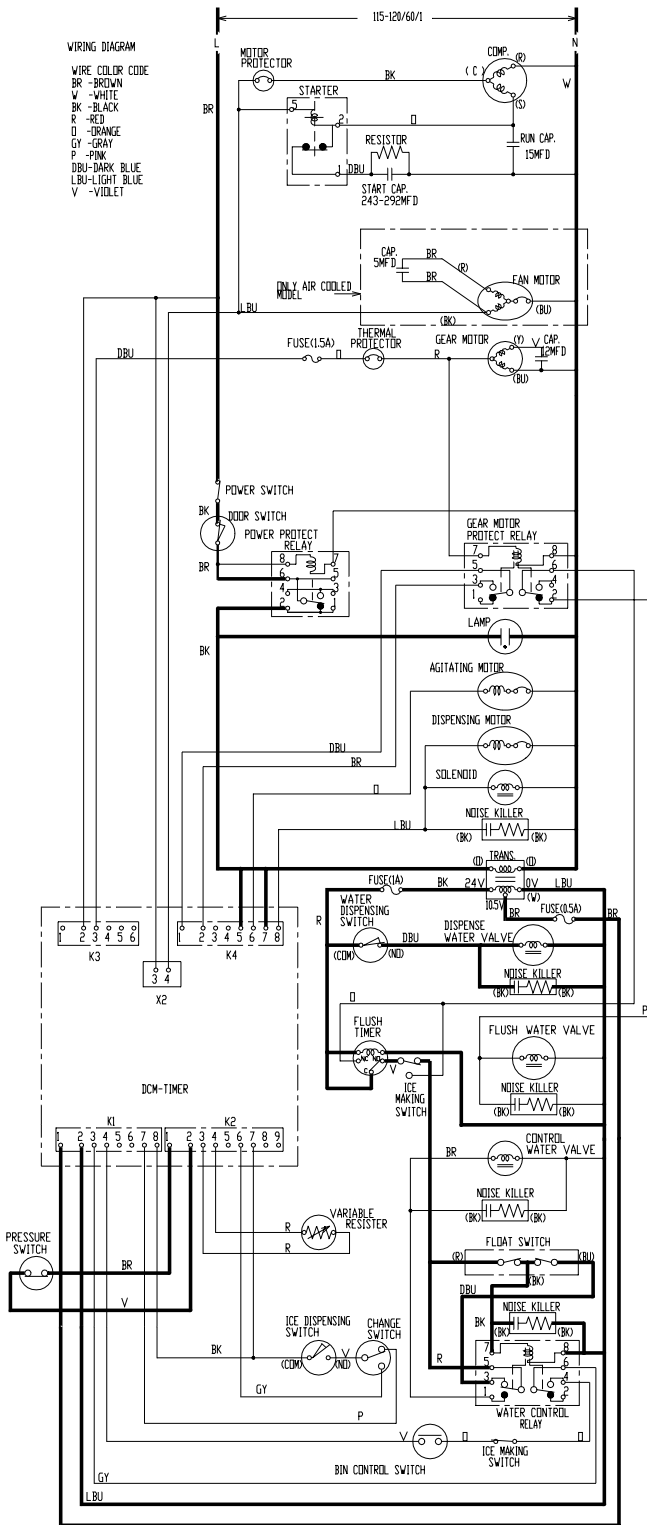

[DCM-500]

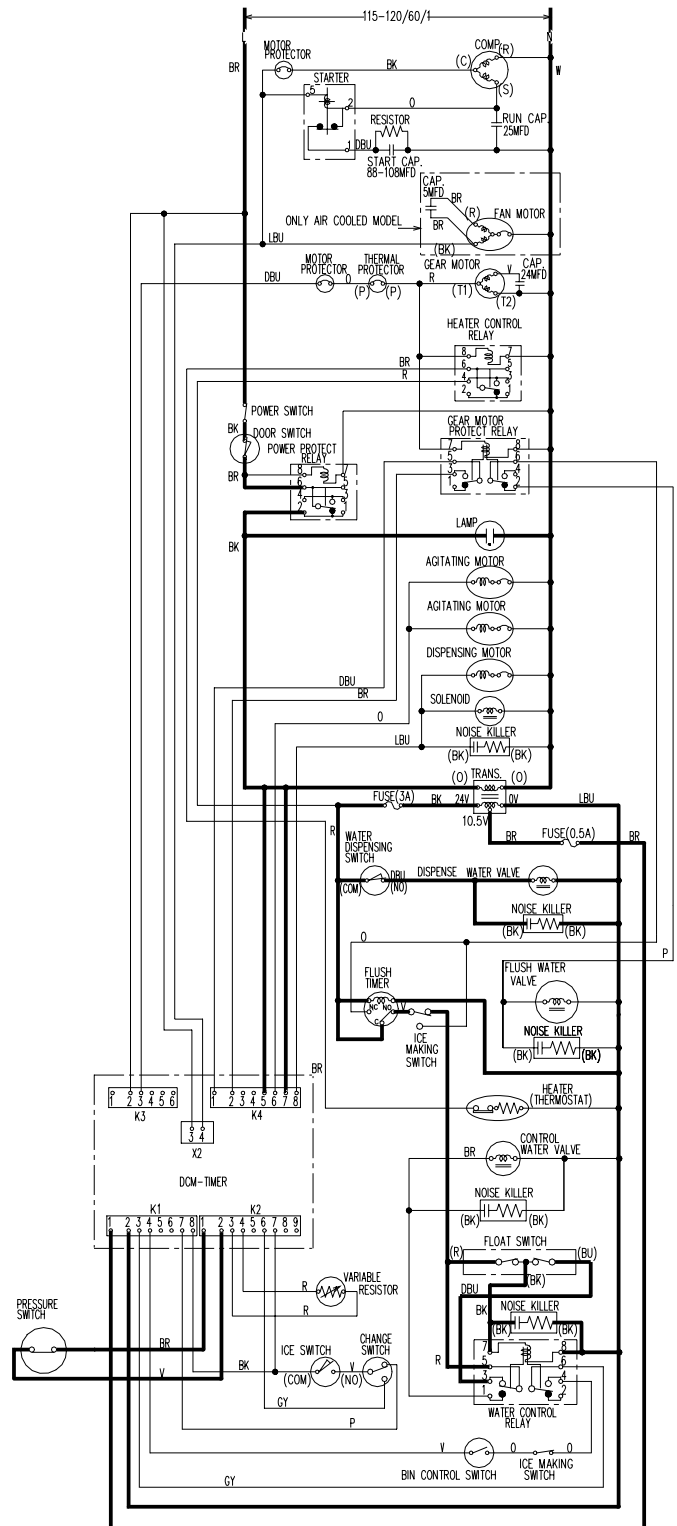

[DCM-750]

[i] Switch Control Switch to drain.

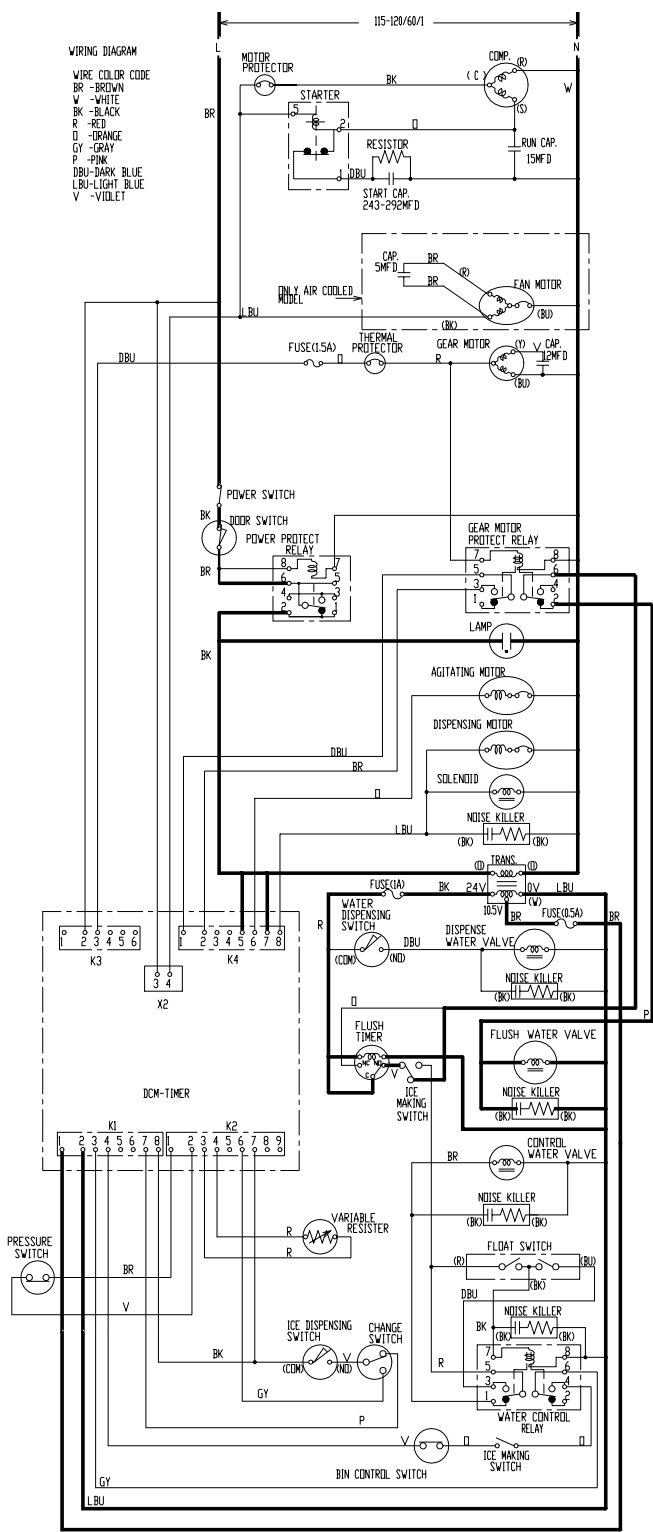

[DCM-500]

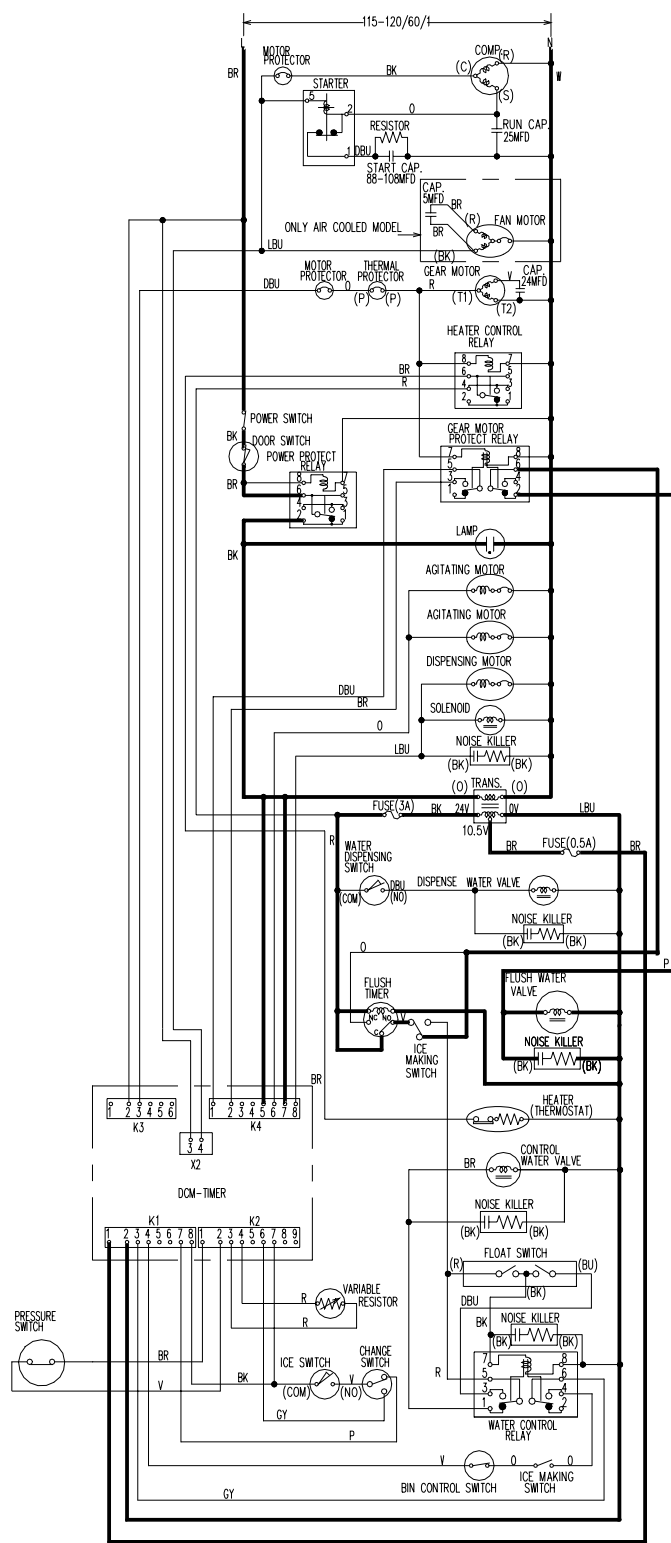

[DCM-750]

[j] Flush Timer activates.

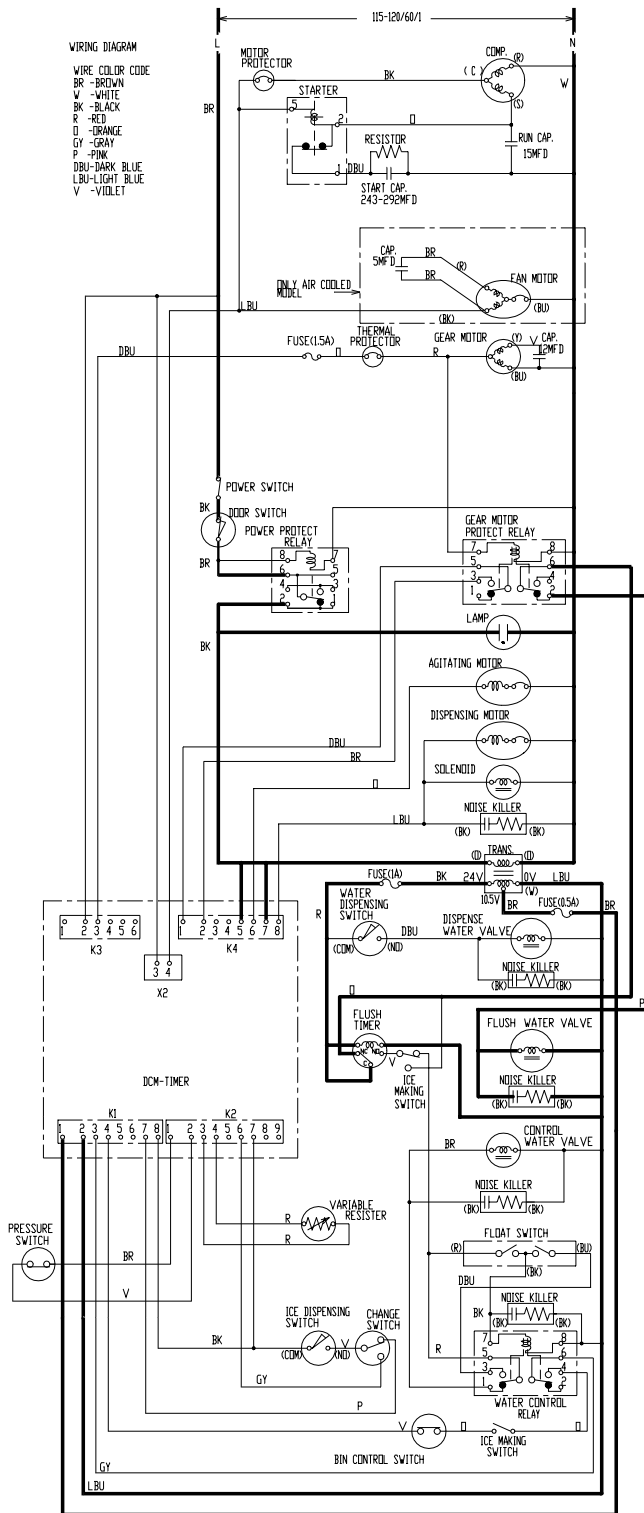

[DCM-500]

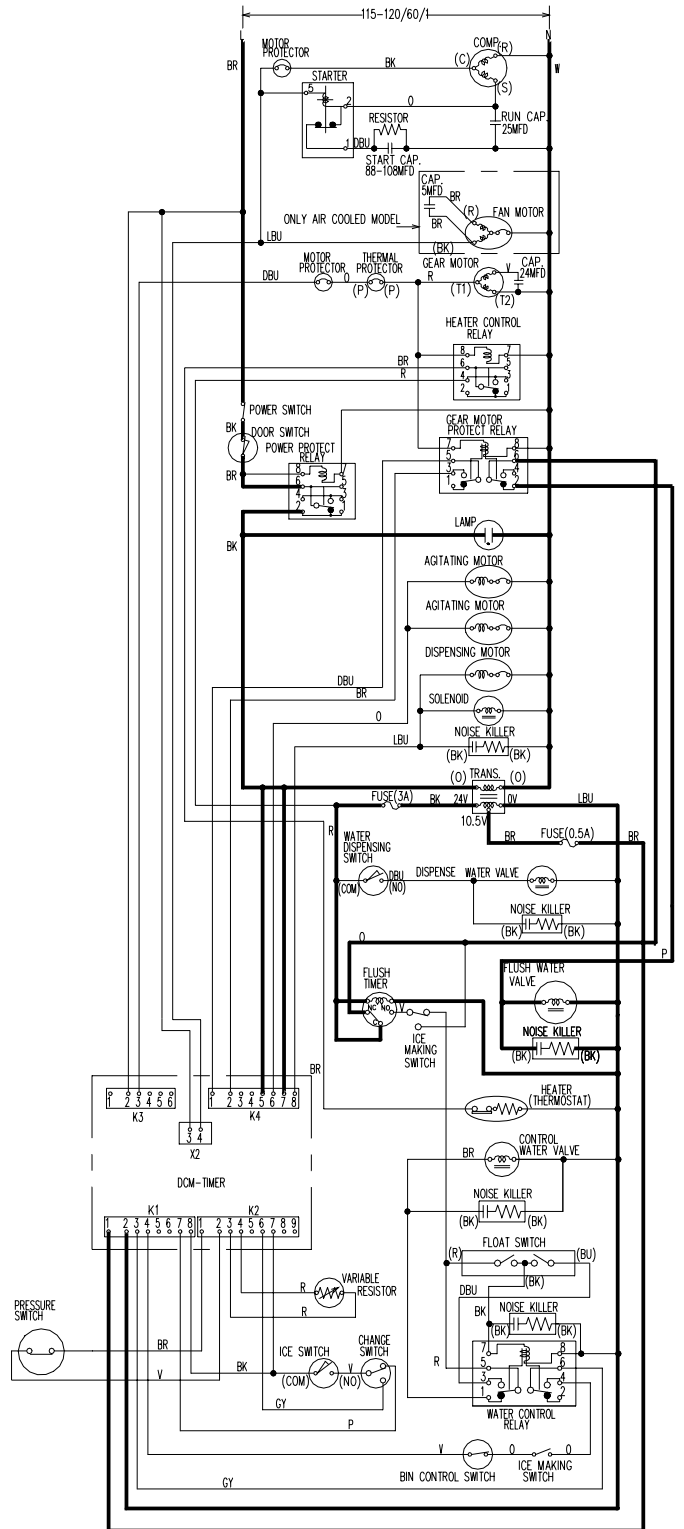

[DCM-750]

[k] When 208-230V are supplied to the Power Supply due to miswiring, Power Protect Relay operates, and the Ice Maker does not run.

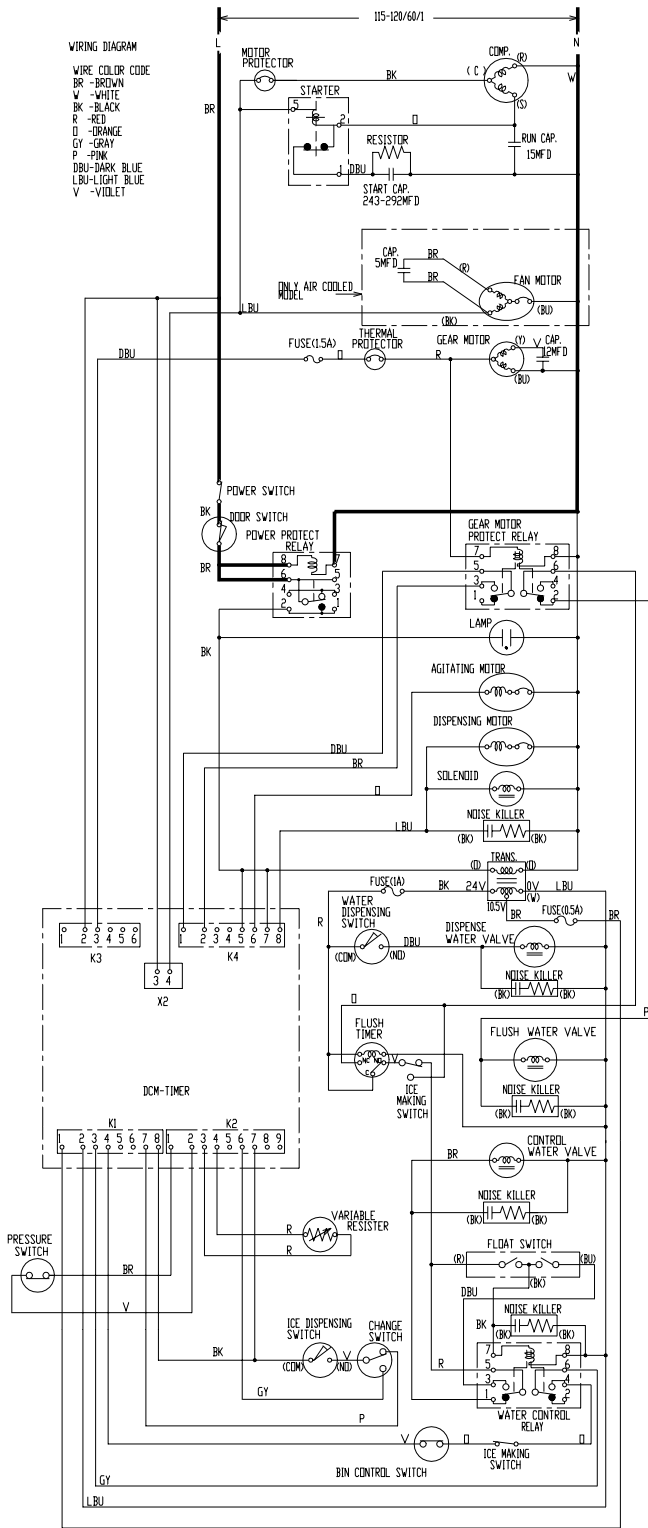

[DCM-500]

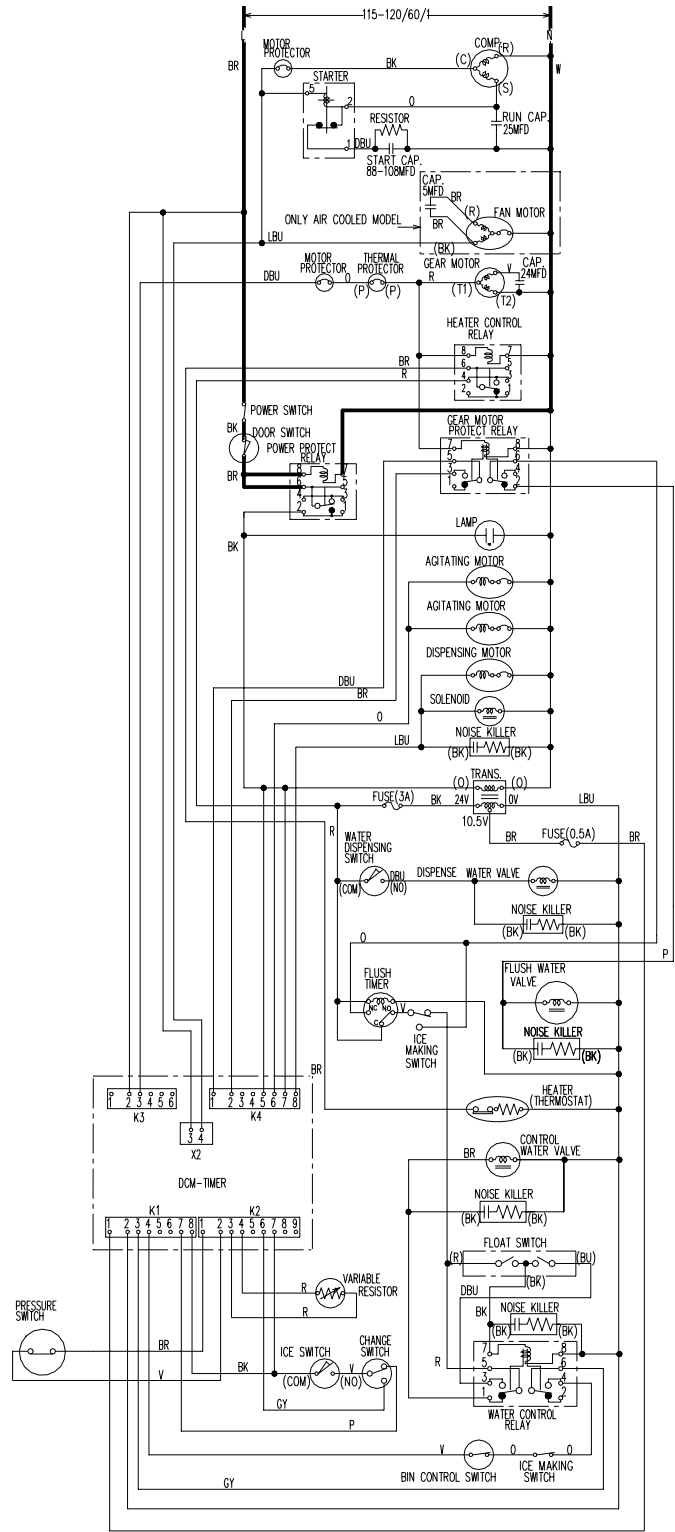

[DCM-750]

[1] When high pressure causes the Pressure Switch to open, the Compressor stops immediately and the Gear Motor stops 60 sec. later.

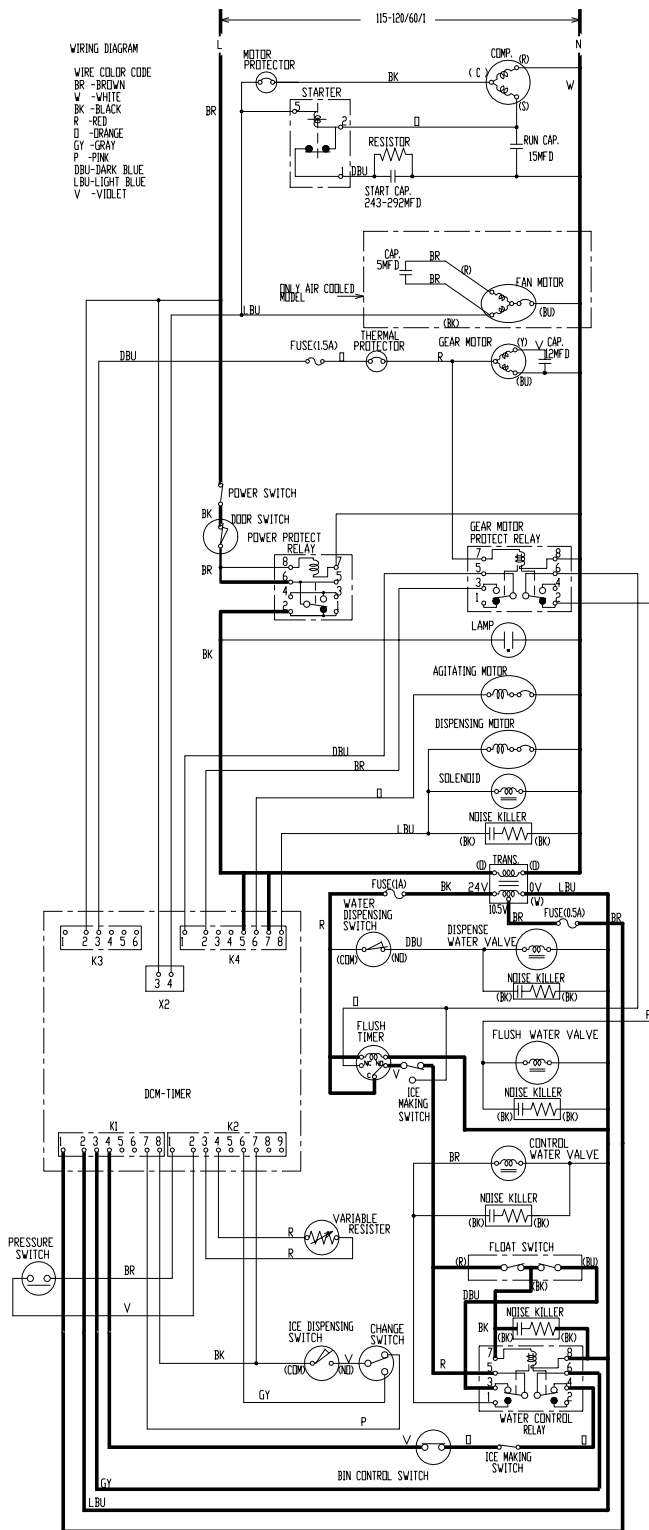

[DCM-500]

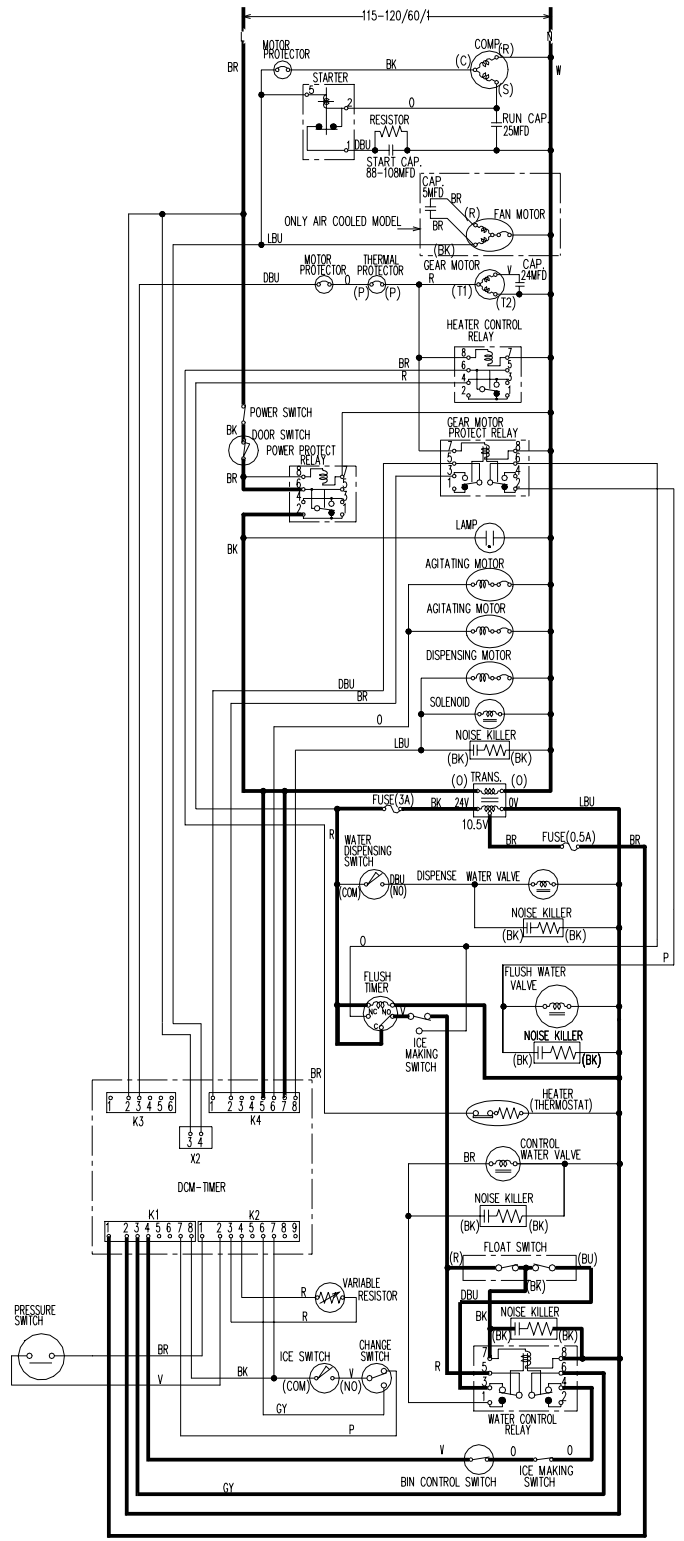

[DCM-750]

4. TIMING CHART

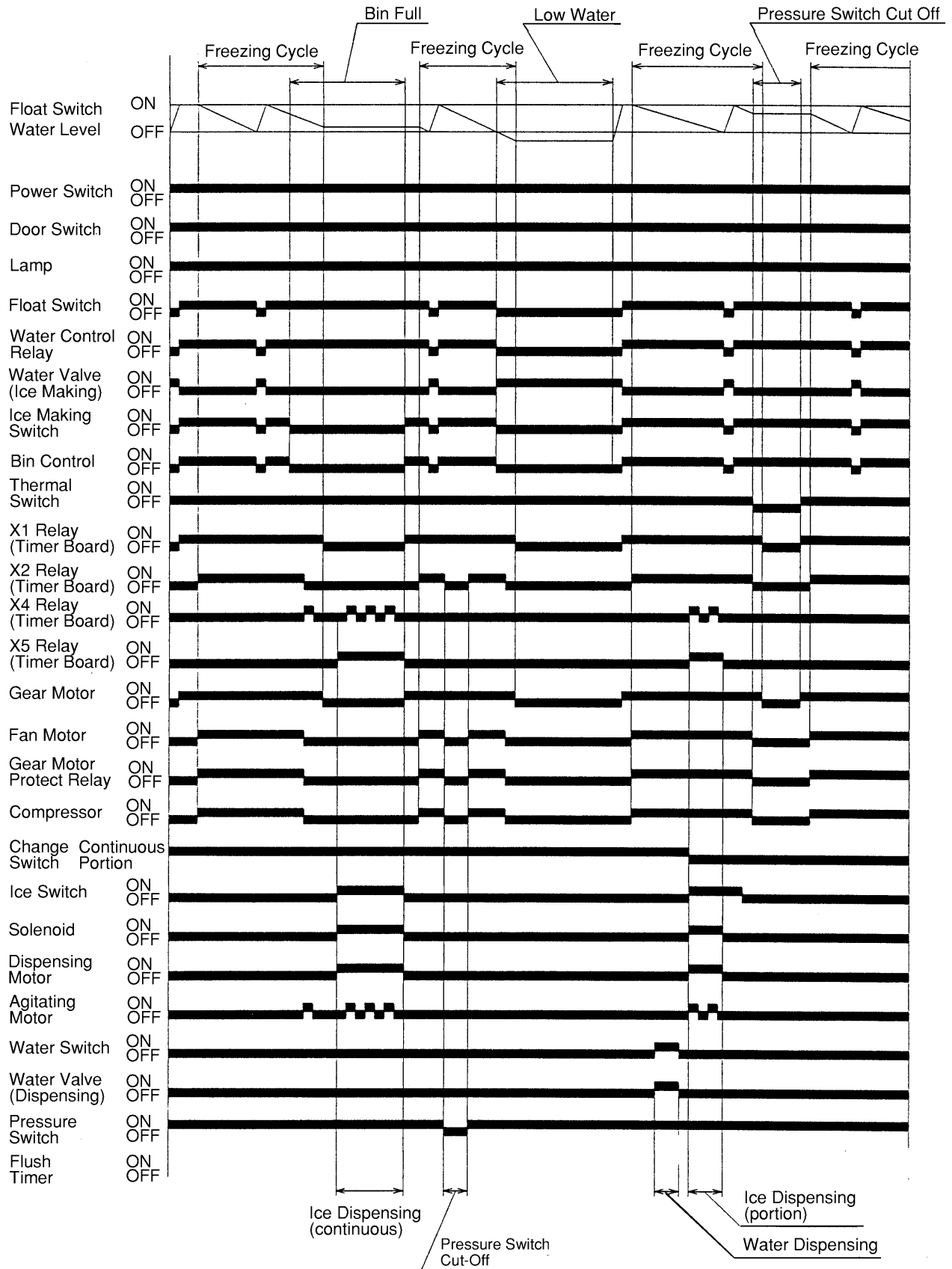

5. TIMER BOARD

[a] SOLID-STATE CONTROL

- 1) A HOSHIZAKI exclusive solid-state control is employed in the DCM-500 and DCM-750 cubelet ice dispenser. This control includes a microprocessor (LSI) developed by HOSHIZAKI.
- 2) A Printed Circuit Board (hereafter called "Timer Board") includes a stable and high quality control system.
- 3) Any complicated adjustment is not required. All models are pretested and factory-adjusted.

[b] TIMER BOARD

CAUTION

1. Fragile, handle very carefully.
2. A timer board contains CMOS (Complementary Metal-Oxide Semiconductor) integrated circuits, which are susceptible to failure due to static discharge. It is especially important to use an antistatic wrist strap when handling or replacing the board.
3. Do not touch the electronic devices on the board or the back of the board to prevent damage to the board.
4. Do not change wiring and connections. Especially, never misconnect K1, K2, K3 and K4.
5. Do not fix the electronic devices or parts on the board in the field. Always replace the whole board assembly when it goes bad.

A timer board, Part Code 2U0098-02 (Model H2AA086C03), is used for DCM-500 and DCM-750 cubelet ice dispensers.

Note: Be sure to use the proper Timer Board for the model that you are working on.

Connector K2

- #1,2 Thermal Switch
- #3,4 Variable Resistor
- #6,7 Ice Switch
(continuous)

Connector K1

- #1,2 Power
- #3,4 Bin Controlled Circuit
- #7,8 Ice Switch
(portion controlled)

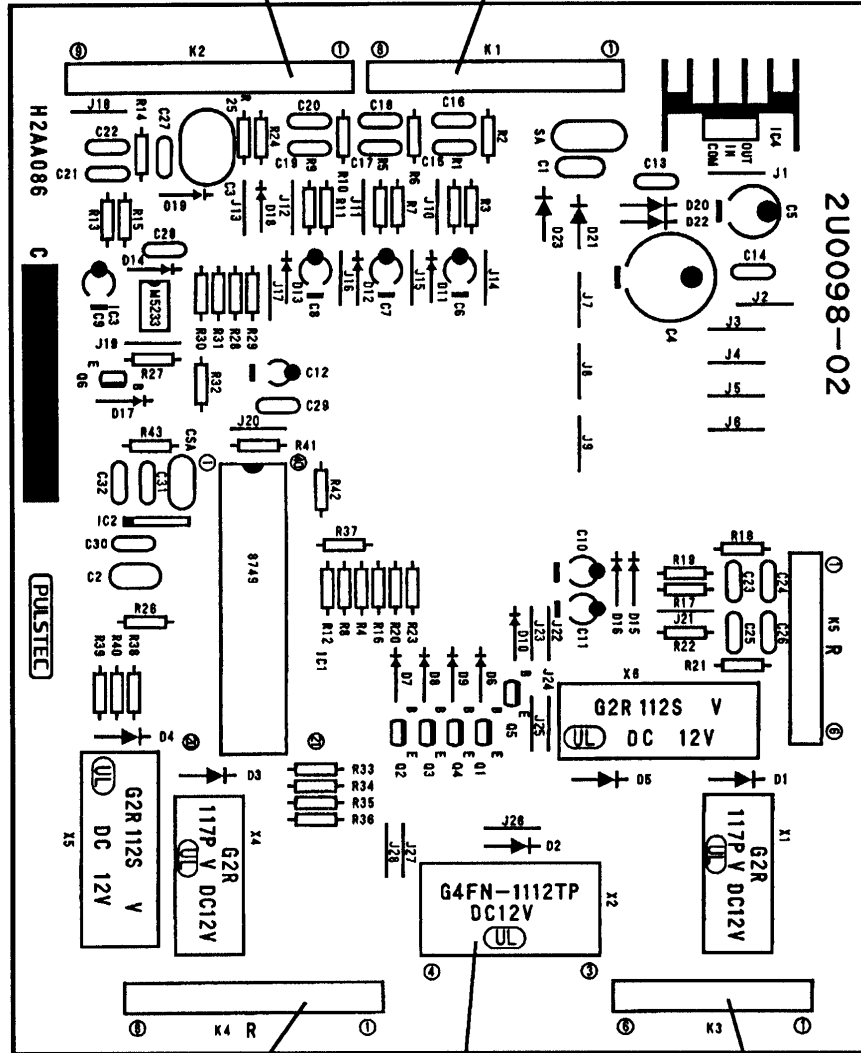

Connector K4

- #1,2 X2 Relay Coil
(Comp. Relay)
- #5,6 X4 Relay
(Agitating Mot.)
- #7,8 X5 Relay
(Dispensing Mot.)
(Solenoid)

X2 Relay

- (Comp. Relay)
- (Fan Mot.)

Connector K3

- #2,3 X1 Relay
(Gear Mot.)

[c] SEQUENCE

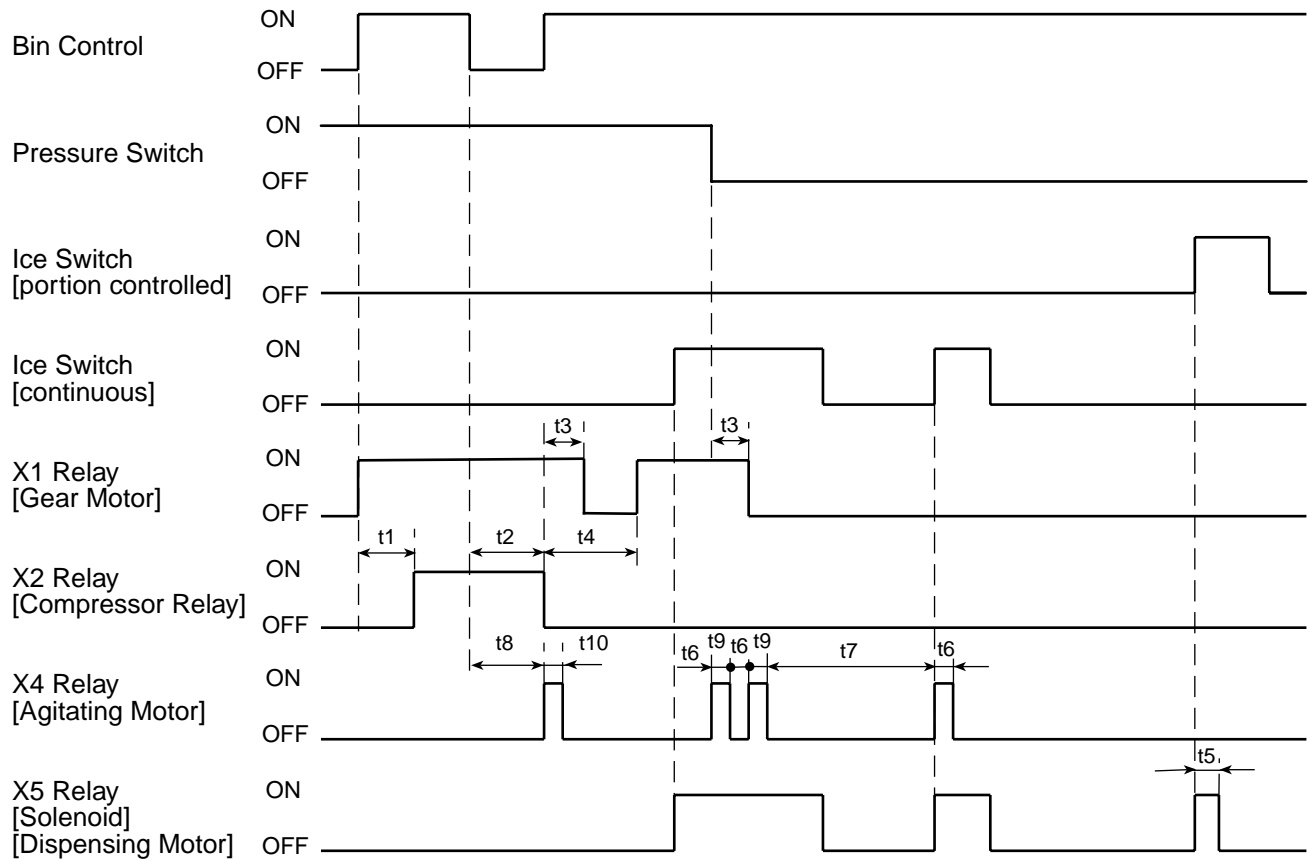

MARK	ITEM	TIME	
t1	X2 Relay ON-delay Time	60 sec.	
t2	X2 Relay OFF-delay Time	90 sec.	
t3	X1 Relay OFF-delay Time	60 sec.	
t4	X1 Relay Restart-delay Time	120 sec.	
t5	X5 Relay ON Time	Minimum	0.6 sec.
		Maximum	20 sec.
t6	X4 Relay Anti-restart Time	12 sec.	
t7	X4 Relay Anti-reset Time	20 sec.	
t8	X4 Relay ON-delay Time	90 sec.	
t9	X4 Relay ON Time (after completing t6)	0.6 sec.	
t10	X4 Relay ON Time (after completing t8)	0.6 sec.	

Functions of Relays

1) X1

- makes just when the Bin Control Circuit closes.
- breaks t3 sec. after X2 breaks following the t2 sec. delay since the Bin Control Circuit opens.
- will not make for t4 sec. after X2 breaks, even if the Bin Control Circuit closes.

2) X2

- makes t1 sec. after the Bin Control Circuit closes.
- breaks t2 sec. after the Bin Control Circuit opens.
- will not make while the Pressure Switch is OFF, whether the Bin Control Circuit is ON or OFF.

3) X4

- makes for t10 sec. after the t8 sec. delay since the Bin Control Circuit closes.
- makes for t9 sec. after the t6 sec. delay since X5 is made by switching ON the Ice Switch (portion controlled) or Ice Switch (continuous).
- makes just when X5 is made by switching ON the Ice Switch (portion controlled) or Ice Switch (continuous), after t7 min. has passed since X4 breaks.

4) X5

- makes for t5 sec. after the Ice Switch (portion controlled) is switched ON.
- is ON while the Ice Switch (continuous) is ON.

4. PERFORMANCE DATA

DCM-500BAF (Air-cooled)

APPROXIMATE ICE PRODUCTION PER 24 HR.	Ambient Temp. (°F)	Water Temp. (°F)					
		50		70		90	
lbs./day (kg/day)	70	*535	*(243)	510	(231)	485	(220)
	80	461	(209)	438	(199)	416	(189)
	90	396	(179)	*385	*(175)	358	(162)
	100	340	(154)	323	(147)	*304	*(138)
APPROXIMATE ELECTRIC CONSUMPTION	70	*985	--	995	--	1005	--
	80	1015	--	1025	--	1035	--
	90	1045	--	*1055	--	1056	--
	100	1058	--	1059	--	*1060	--
APPROXIMATE WATER CONSUMPTION PER 24 HR.	70	*64	*(243)	61	(231)	58	(220)
	80	55	(209)	53	(199)	50	(189)
	90	48	(179)	*46	*(175)	43	(162)
	100	41	(154)	39	(147)	*37	*(138)
EVAPORATOR OUTLET TEMP. °F (°C)	70	*23	*(-5)	23	(-5)	23	(-5)
	80	23	(-5)	26	(-4)	26	(-4)
	90	26	(-4)	*26	*(-4)	28	(-3)
	100	28	(-3)	28	(-3)	*28	*(-3)
HEAD PRESSURE	70	*230	*(16.2)	230	(16.2)	230	(16.2)
	80	264	(18.5)	264	(18.5)	264	(18.5)
	90	297	(20.9)	*297	*(20.9)	297	(20.9)
	100	335	(23.5)	335	(23.5)	*335	*(23.5)
SUCTION PRESSURE PSIG (kg/cm ² G)	70	*33	*(2.3)	33	(2.3)	33	(2.3)
	80	35	(2.5)	35	(2.5)	35	(2.5)
	90	37	(2.6)	*37	*(2.6)	37	(2.6)
	100	43	(3.0)	43	(3.0)	*43	*(3.0)
TOTAL HEAT OF REJECTION		6300 BTU/h (AT 90 °F /WT 70 °F)					

Note: The data without *marks should be used for reference.

We reserve the right to make changes in specifications and design without prior notice.

DCM-500BWF (Water-cooled)

APPROXIMATE ICE PRODUCTION PER 24 HR.	Ambient Temp. (°F)	Water Temp. (°F)					
		50		70		90	
lbs./day (kg/day)	70	*545	*(247)	526	(223)	515	(233)
	80	503	(228)	493	(223)	482	(219)
	90	471	(214)	*465	*(211)	451	(205)
	100	441	(200)	432	(196)	*400	*(181)
APPROXIMATE ELECTRIC CONSUMPTION	70	*920	--	930	--	940	--
	80	920	--	930	--	940	--
	90	920	--	*930	--	940	--
	100	920	--	930	--	*940	--
APPROXIMATE WATER CONSUMPTION PER 24 HR. (TOTAL) gal. / day (kl/day)	70	*350	*(1.59)	474	(2.16)	757	(3.44)
	80	369	(1.68)	498	(2.26)	801	(3.64)
	90	386	(1.76)	*521	*(2.37)	848	(3.85)
	100	405	(1.84)	553	(2.51)	*943	*(4.29)
EVAPORATOR OUTLET TEMP. °F (°C)	70	*23	*(-5)	23	(-5)	25	(-4)
	80	23	(-5)	23	(-5)	25	(-4)
	90	23	(-5)	*23	*(-5)	25	(-4)
	100	23	(-5)	23	(-5)	*25	*(-4)
HEAD PRESSURE PSIG (kg/cm²G)	70	*265	*(18.6)	265	(18.6)	265	(18.6)
	80	265	(18.6)	265	(18.6)	265	(18.6)
	90	265	(18.6)	*265	*(18.6)	265	(18.6)
	100	265	(18.6)	265	(18.6)	*265	*(18.6)
SUCTION PRESSURE PSIG (kg/cm²G)	70	*37	*(2.6)	*37	(2.6)	*38	(2.7)
	80	37	(2.6)	37	(2.6)	38	(2.7)
	90	37	(2.6)	*37	*(2.6)	38	(2.7)
	100	37	(2.6)	37	(2.6)	*38	*(2.7)
TOTAL HEAT OF REJECTION		5575 BTU/h (AT 90 °F /WT 70 °F)					

Note: The data without *marks should be used for reference.

We reserve the right to make changes in specifications and design without prior notice.

DCM-750BAF (Air-cooled)

APPROXIMATE ICE PRODUCTION PER 24 HR.	Ambient Temp. (°F)	Water Temp. (°F)					
		50		70		90	
lbs./day (kg/day)	70	*803	*(364)	770	(349)	726	(329)
	80	684	(310)	645	(293)	608	(276)
	90	573	(260)	*567	*(257)	509	(231)
	100	480	(218)	452	(205)	*423	*(192)
APPROXIMATE ELECTRIC CONSUMPTION	70	*1449	--	1454	--	1458	--
	80	1463	--	1467	--	1472	--
	90	1476	--	*1481	--	1483	--
	100	1486	--	1488	--	*1490	--
APPROXIMATE WATER CONSUMPTION PER 24 HR.	70	*96	*(364)	92	(349)	87	(329)
	80	82	(310)	77	(293)	73	(276)
	90	69	(260)	*68	*(257)	61	(231)
	100	58	(218)	54	(205)	*51	*(192)
EVAPORATOR OUTLET TEMP.	70	*30	*(-1)	30	(-1)	30	(-1)
	80	30	(-1)	32	(0)	32	(0)
	90	32	(0)	*32	*(0)	33	(1)
	100	33	(1)	33	(1)	*33	*(1)
HEAD PRESSURE	70	*249	*(17.5)	249	(17.5)	249	(17.5)
	80	280	(19.6)	280	(19.6)	280	(19.6)
	90	310	(21.8)	*310	*(21.8)	310	(21.8)
	100	346	(24.3)	346	(24.3)	*346	*(24.3)
SUCTION PRESSURE	70	*44	*(3.1)	44	(3.1)	44	(3.1)
	80	47	(3.3)	47	(3.3)	47	(3.3)
	90	49	(3.4)	*49	*(3.4)	49	(3.4)
	100	52	(3.7)	52	(3.7)	*52	*(3.7)
TOTAL HEAT OF REJECTION		8314 BTU/h (AT 90°F /WT 70°F)					

Note: The data without *marks should be used for reference.

We reserve the right to make changes in specifications and design without prior notice.

DCM-750BWF (Water-cooled)

APPROXIMATE ICE PRODUCTION PER 24 HR.	Ambient Temp. (°F)	Water Temp. (°F)		
		50	70	90
	70	*879 *(399)	851 (386)	830 (376)
	80	809 (367)	789 (358)	770 (349)
	90	751 (341)	*746 *(338)	714 (324)
lbs./day (kg/day)	100	697 (316)	679 (308)	*628 *(285)
APPROXIMATE ELECTRIC CONSUMPTION	70	*1367 --	1364 --	1362 --
	80	1359 --	1357 --	1354 --
	90	1352 --	*1349 --	1349 --
	watts	100	1349 --	1348 --
APPROXIMATE WATER CONSUMPTION PER 24 HR. (TOTAL)	70	*526 *(2.39)	92 (2.95)	87 (4.70)
	80	554 (2.52)	77 (3.11)	73 (5.00)
	90	583 (2.65)	*68 *(3.24)	61 (5.32)
	gal./day (l/day)	100	614 (2.79)	54 (3.49)
EVAPORATOR OUTLET TEMP.	70	*30 *(-1)	30 (-1)	30 (-1)
	80	30 (-1)	30 (-1)	30 (-1)
	90	30 (-1)	*30 *(-1)	32 (0)
	°F (°C)	100	32 (0)	32 (0)
HEAD PRESSURE	70	*255 *(17.9)	255 (17.9)	255 (17.9)
	80	256 (18.0)	256 (18.0)	256 (18.0)
	90	256 (18.0)	*256 *(18.0)	256 (18.0)
	PSIG (kg/cm ² G)	100	259 (18.2)	259 (18.2)
SUCTION PRESSURE	70	*44 *(3.1)	44 (3.1)	44 (3.1)
	80	45 (3.1)	45 (3.1)	45 (3.1)
	90	45 (3.2)	*45 *(3.2)	45 (3.2)
	PSIG (kg/cm ² G)	100	47 (3.3)	47 (3.3)
WATER FLOW FOR CONDENSER		51 gal/h (AT 100°F /WT 90°F)		
PRESSURE DROP OF COOLING WATER LINE		Less than 7 PSIG		
HEAT OF REJECTION FROM CONDENSER		5130 BTU/h (AT 90°F /WT 70°F)		
HEAT OF REJECTION FROM COMPRESSOR		7021 BTU/h (AT 90°F /WT 70°F)		

Note: The data without *marks should be used for reference.

We reserve the right to make changes in specifications and design without prior notice.

IV. ADJUSTMENT OF COMPONENTS

1. ADJUSTMENT OF WATER REGULATING VALVE - WATER-COOLED MODEL ONLY

The Water Regulating Valve, also called "WATER REGULATOR," is factory-adjusted. No adjustment is required under normal use. Adjust the Water Regulator, if necessary, using the following procedures.

- 1) Attach a pressure gauge to the high-side line of the system. Or prepare a thermometer to check the condenser drain temperature.
- 2) Rotate the Adjustment Screw by using a flat blade screwdriver, so that the pressure gauge shows 260 PSIG, or the thermometer reads 100 - 104°F, in 5 minutes after the icemaking process starts. When the pressure exceeds 260 PSIG, or the condenser drain temperature exceeds 104°F, rotate the Adjustment Screw counterclockwise.
- 3) Check that the pressure or the condenser drain temperature holds a stable setting.

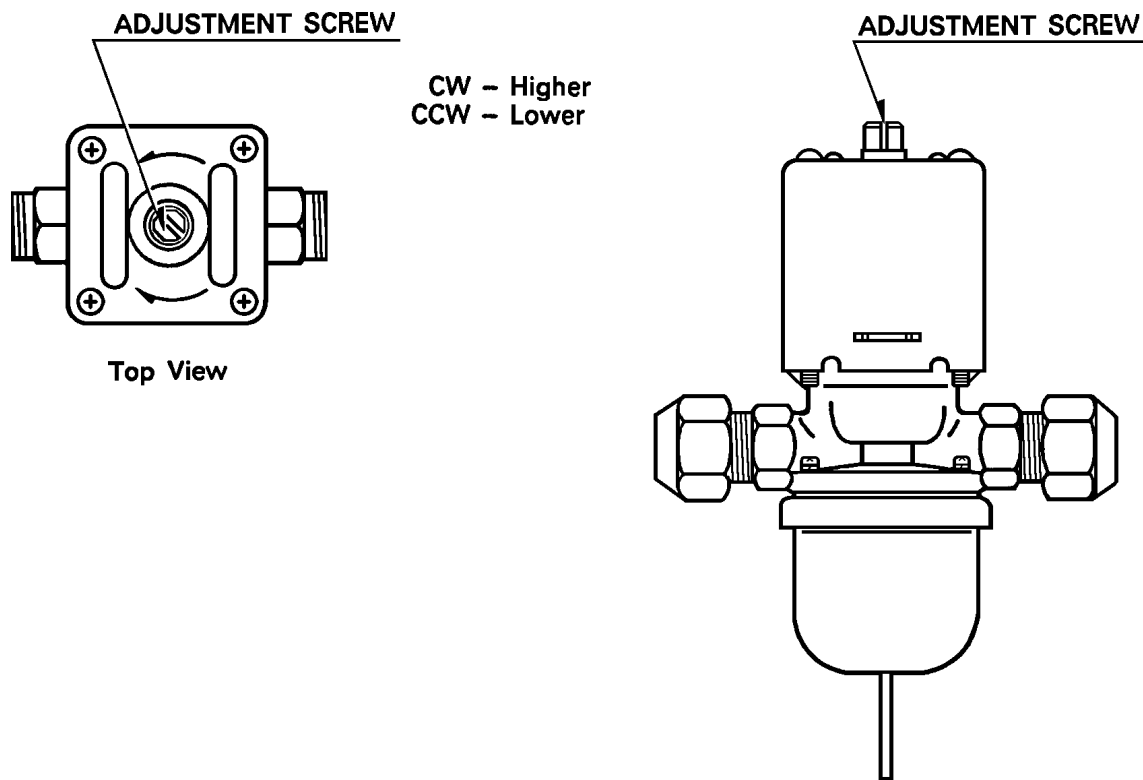

V. SERVICE DIAGNOSIS

PROBLEM	POSSIBLE CAUSE	REMEDY	
[1] The icemaker will not start.	a) Power Supply	1. OFF position.	1. Move to ON position.
		2. Loose connection.	2. Tighten.
		3. Bad contacts.	3. Check for continuity and replace.
		4. Blown fuse.	4. Replace.
	b) Power Switch (Control Box)	1. Off position.	1. Move to ON position.
		2. Bad contacts.	2. Check for continuity and replace.
	c) Fuse (Control Box)	1. Blown out.	1. Check for short circuit and replace.
	d) Door Switch (Control Box)	1. Not activated.	1. Replace Upper Front Panel.
2. Bad contacts.		2. Check for continuity and replace.	
[2] Ice dispensing operates, but no ice is produced.	a) Water Control Relay	1. Bad contacts.	1. Check for continuity and replace.
		2. Coil winding opened.	2. Replace.
	b) Pressure Switch	1. Bad contacts.	1. Check for continuity and replace.
		2. Loose connections.	2. Tighten.
	c) Compressor	1. Does not start.	1. See "[4] Compressor will not start, or operates intermittently."
	[3] Water Valve operates, but no ice is produced.	a) Shut-off Valve	1. Closed.
2. Water failure.			2. Wait till water is supplied.
b) Water Valve		1. Clogged.	1. Clean. See "V. 2. [c] WATER VALVE".
c) Bin Control		1. Tripped with bin filled with ice.	1. Remove ice.
		2. Out of position.	2. Place in position.
		3. Bad contacts.	3. Check for continuity and replace.
		4. Activator removed.	4. Place in position.
d) Pressure Switch		1. Bad contacts.	1. Check for continuity and replace.
		2. Loose connections.	2. Tighten.
e) Ice Making Switch		1. Bad contacts.	1. Check for continuity and replace.
		2. Loose connections.	2. Tighten.
f) Compressor		1. Will not start.	1. See [4] Compressor will not start, or operates intermittently."
[4] Compressor will not start, or operates intermittently.		a) Pressure Switch	1. Dirty Air Filter or Condenser.
	2. Ambient or condenser water temperature too warm.		2. Get cooler.

PROBLEM	POSSIBLE CAUSE		REMEDY
		3. Refrigerant overcharged.	3. Recharge.
		4. Fan not operating.	4. See "[7] Fan Motor will not start, or is not operating."
		5. Refrigerant line or components clogged	5. Clean and replace drier.
		6. Bad contacts.	6. Check for continuity and replace.
		7. Loose connections.	7. Tighten.
	b) Overload Protector	1. Bad contacts.	1. Check for continuity and replace.
		2. Voltage too low.	2. Get higher voltage.
		3. Refrigerant overcharged,	3. Recharge.
	c) Starter	1. Bad contacts.	1. Check for continuity and replace.
		2. Coil winding opened.	2. Replace.
		3. Loose connections,	3. Tighten.
	d) Starting or Running Capacitor	1. Defective.	1. Replace.
	e) X2 Relay on Timer Board	1. Bad contacts.	1. Check for continuity and replace Timer Board.
		2. Coil winding opened.	2. Replace Timer Board.
	f) Compressor	1. Loose connections.	1. Tighten.
	2. Motor winding opened or earthed.	2. Replace.	
g) Fan Motor	1. Fan not rotating.	1. See [7] Fan Motor will not start, or is not operating.	
[5] Poor ice production capacity.	a) Condenser	1. Dirty Air Filter or Condenser.	1. See [4] - a)
		2. Bad ventilation.	2. Remove anything blocking vents.
	b) Expansion Valve	1. Low-side pressure or temperature exceeding the limit.	1. Secure the Bulb or replace the whole valve.
	c) Refrigerant Lines	1. Gas leaks.	1. Check for leaks with a leak detector. Reweld leak, replace drier and charge with refrigerant. The amount of refrigerant is marked on Nameplate.
	d) Installation Site	1. Ambient temperature too high.	1. Check ventilation and location, and change as needed.
		2. Less than 15 cm clearance at rear and sides.	2. Allow proper clearance for ventilation.

PROBLEM	POSSIBLE CAUSE		REMEDY
	e) Inside Wall of Evaporator	1. Scale on inside wall of Freezing Cylinder.	1. Remove Auger. Use a solution of lime removing cleaner to clean periodically. If water is found to surpass the following levels, install a conditioner. Hardness 50ppm Silica 30ppm
	f) Water Supply	1. Water supply interrupted or pressure too low.	1. Check water supply.
[6] Dispenser will not stop even if Bin is filled with ice.	a) Bin Control	1. Activator does not move freely.	1. Check and replace.
		2. Contacts fused.	2. Replace
[7] Fan Motor will not start, or is not operating.	a) Fan Motor	1. Motor winding opened.	1. Replace.
		2. Bearing worn out.	2. Replace.
		3. Wiring to Fan Motor.	3. Check for loose connections or open, and replace.
		4. Defective Capacitor.	4. Replace.
		5. Fan blade bound.	5. Check and replace.
[8] Gear Motor (Ice Making) is not operating.	a) Gear Motor	1. Motor winding opened.	1. Replace.
	b) X1 Relay on Timer Board	1. Bad contacts.	1. Check for continuity and replace Timer Board.
		2. Coil winding opened.	2. Replace Timer Board.
[9] Auger Shaft worn out.	a) Water	1. Too much impurity.	1. If wear is excessive, replace.
[10] Abnormal noise.	a) Fan Motor	1. Bearings worn out.	1. Replace.
		2. Blade is deformed.	2. Replace Fan Blade.
		3. Fan blade does not move freely.	3. Replace.
	b) Compressor	1. Bearings worn out.	1. Replace.
		2. Mounting pad out of position.	2. Reinstall.
	c) Refrigerant Lines	1. Rub or touch lines or other surfaces.	1. Replace.
	d) Gear Motor (Ice Making)	1. Bearing or Gear worn/damaged.	1. Replace.
	e) Evaporator	1. Low-side pressure too low.	1. See [5] - b)
		2. Scale on inside wall of Freezing Cylinder.	2. See [5] - e)

PROBLEM	POSSIBLE CAUSE	REMEDY
	f) Agitator Motor Dispensing Motor	1. Bearing or Gear worn/damaged.
	g) Solenoid (Shutter)	1. Worn out.
		2. Foreign matter on Plunger surface.
	h) Water Valve	1. Foreign matter on Plunger surface.
[11] Water does not stop.	a) Water Supply	1. Water pressure too high.
	b) Water Valve	1. Diaphragm does not close.
	c) Float Switch	1. Bad contacts.
	d) Water Control Relay	1. Contacts fused.
2. Coil winding opened.		
[12] No water or poor flow.	a) Water Supply	1. Water failure or pressure too low.
		2. Shut-off Valve closed or restricted.
	b) Water Valve	1. Clogged filter.
		2. Coil winding opened.
	c) Float Switch	1. Contacts fused.
		2. Clogged.
	d) Water Control Relay	1. Bad contacts.
	[13] Much water drains from Evaporator bottom.	a) Mechanical Seal (normally less than 0.5 ml/h)
2. Seal worn out.		
b) O-ring	1. Scratched.	
[14] No ice is dispensed with Push Lever pressed.	a) Ice Switch	1. Bad contacts.
		2. Screws loosened.
	b) Solenoid (Shutter)	1. Coil winding opened.
		2. Worn out.
		3. Shutter Plate blocked.
	c) Change Switch	1. Bad contacts.
		2. Loose connections.
[15] Ice in Storage Bin often melts.	a) Drain Bin	1. Clogged.

VI. REMOVAL AND REPLACEMENT OF COMPONENTS

IMPORTANT

Ensure all components, fasteners and thumbscrews are securely in place after the equipment is serviced.

IMPORTANT

1. The Polyol Ester (POE) oils used in R-404A units can absorb moisture quickly. Therefore it is important to prevent moisture from entering the system when replacing or servicing parts.
2. Always install a new filter drier every time the sealed refrigeration system is opened.
3. Do not leave the system open for longer than 5 minutes when replacing or servicing parts.

1. SERVICE FOR REFRIGERANT LINES

[a] REFRIGERANT RECOVERY

The icemaker unit is provided with two Refrigerant Access Valves—one on the low-side and one on the high-side line. Using proper refrigerant practices, recover the refrigerant from these two Access Valves and store it in an approved container. Do not discharge the refrigerant into the atmosphere.

[b] EVACUATION AND RECHARGE [R-404A]

- 1) Attach Charging Hoses, a Service Manifold and a Vacuum Pump to the system. Be sure to connect charging hoses to both High and Low-side Access Valves.

IMPORTANT

The vacuum level and Vacuum Pump may be the same as those for current refrigerants. However, the rubber hose and gauge manifold to be used for evacuation and refrigerant charge should be exclusively for POE oils.

- 2) Turn on the Vacuum Pump. Never allow the oil in the Vacuum Pump to flow backward.
- 3) Allow the Vacuum Pump to pull down to a 29.9" Hg vacuum. Evacuating period depends on pump capacity.

- 4) Close the Low-side Valve and High-side Valve on the Service Manifold.
- 5) Disconnect the Vacuum Pump, and attach a Refrigerant Service Cylinder to the High-side line. Remember to loosen the connection, and purge the air from the Hose. See the Nameplate for the required refrigerant charge. Hoshizaki recommends only virgin refrigerant or reclaimed refrigerant which meets ARI Standard No. 700-88 be used.
- 6) A liquid charge is recommended for charging an R-404A system. Invert the service cylinder. Open the High-side, Service Manifold Valve.
- 7) Allow the system to charge with liquid until the pressures balance.
- 8) If necessary, add any remaining charge to the system through the Low-side. Use a throttling valve or liquid dispensing device to add the remaining liquid charge through the Low-side access port with the unit running.
- 9) Close the two Refrigerant Access Valves, and disconnect the Hoses and Service Manifold.
- 10) Cap the Access Valves to prevent a possible leak.

2. BRAZING

DANGER

1. Refrigerant R-404A itself is not flammable at atmospheric pressure and temperatures up to 176° F.
2. Refrigerant R-404A itself is not explosive or poisonous. However, when exposed to high temperatures (open flames) R-404A can be decomposed to form hydrofluoric acid and carbonyl fluoride both of which are hazardous.
3. Always recover the refrigerant and store it in an approved container. Do not discharge the refrigerant into the atmosphere.
4. Do not use silver alloy or copper alloy containing Arsenic.
5. Do not use R-404A as a mixture with pressurized air for leak testing. Refrigerant leaks can be detected by charging the unit with a little refrigerant, raising the pressure with nitrogen and using an electronic leak detector.

Note: All brazing connections are clear-paint coated.
Sandpaper the brazing connections before unbrazing the components.
Use a good abrasive cloth to remove coating.

3. REMOVAL AND REPLACEMENT OF COMPRESSOR

IMPORTANT

Always install a new Drier every time the sealed refrigeration system is opened. Do not replace the Drier until after all other repair or replacement has been made.

Note: When replacing a Compressor with a defective winding, be sure to install the new Start Capacitor and Start Relay supplied with the replacement Compressor. Due to the ability of the POE oil in the compressor to absorb moisture quickly, the Compressor must not be opened more than 15 minutes for replacement or service. Do not mix lubricants of different compressors even if both are charged with R-404A, except when they use the same lubricant.

- 1) Turn off the power supply.
- 2) Remove the panels.
- 3) Remove the Terminal Cover on the Compressor, and disconnect the Compressor Wiring.
- 4) Recover the refrigerant and store it in an approved container.
- 5) Remove the Discharge and Suction Pipes using brazing equipment.

WARNING

When repairing a refrigerant system, be careful not to let the burner flame contact the lead wires or insulation.

- 6) Remove the Hold-down Bolts, and Rubber Grommets.
- 7) Slide and remove the Compressor. Unpack the new Compressor package. Install the new Compressor.
- 8) Attach the Rubber Grommets of the prior Compressor.
- 9) Sandpaper the Suction, Discharge and Access Pipes.
- 10) Place the Compressor in position, and secure it using the Bolts and Washers.
- 11) Remove plugs from the Suction, Discharge and Process Pipes.

- 12) Braze the Access, Suction and Discharge lines (Do not change this order), while purging with nitrogen gas flowing at the pressure 3-4 PSIG.
- 13) Install the new Drier.
- 14) Check for leaks using nitrogen gas (140 PSIG) and soap bubbles.
- 15) Connect the Terminals, and replace the Terminal Cover in its correct position.
- 16) Evacuate the system, and charge it with refrigerant. See the Nameplate for the required refrigerant charge.
- 17) Replace the panels in their correct positions.
- 18) Turn on the power supply.

4. REMOVAL AND REPLACEMENT OF DRIER

IMPORTANT

Always install a new Drier every time the sealed refrigeration system is opened. Do not replace the Drier until after all other repair or replacement has been made.

- 1) Turn off the power supply.
- 2) Remove the panels.
- 3) Recover the refrigerant and store it in an approved container.
- 4) Remove the Drier using brazing equipment.
- 5) Install the new Drier, in the direction of the refrigerant flow. Use nitrogen gas at the pressure of 3-4 PSIG when brazing the tubings.
- 6) Check for leaks using nitrogen gas (140 PSIG) and soap bubbles.
- 7) Evacuate the system, and charge it with refrigerant. See the Nameplate for the required refrigerant charge.
- 8) Replace the panels in their correct positions.
- 9) Turn on the power supply.

5. REMOVAL AND REPLACEMENT OF EXPANSION VALVE

IMPORTANT

Sometimes moisture in the refrigerant circuit exceeds the Drier capacity and freezes up at the Expansion Valve. Always install a new Drier every time the sealed refrigeration system is opened. Do not replace the Drier until after all other repair or replacement has been made.

- 1) Turn off the power supply.
- 2) Remove the panels.
- 3) Recover the refrigerant and store it in an approved container.
- 4) Remove the insulation and the Expansion Valve Bulb at the Evaporator outlet.
- 5) Remove the Expansion Valve Cover, and disconnect the Expansion Valve using brazing equipment.
- 6) Braze the new Expansion Valve, with nitrogen gas flowing at the pressure of 3-4 PSIG.

WARNING

1. Do not heat the wall. Place a steel barrier for protection.
2. Always protect the valve body by using a damp cloth to prevent the valve from overheating. Do not braze with the valve body exceeding 250°F.

- 7) Install the new Drier.
- 8) Check for leaks using nitrogen gas (140 PSIG) and soap bubbles.
- 9) Evacuate the system, and charge it with refrigerant. See the Nameplate for the required refrigerant charge.
- 10) Attach the Bulb to the suction line. Be sure to secure the Bulb using a band and to insulate it.
- 11) Place the new set of Expansion Valve Covers in position.
- 12) Replace the panels in their correct position, and turn on the power supply.

6. REMOVAL AND REPLACEMENT OF WATER REGULATING VALVE - WATER-COOLED MODEL ONLY

IMPORTANT

Always install a new Drier every time the sealed refrigeration system is opened. Do not replace the Drier until after all other repair or replacement has been made.

- 1) Turn off the power supply.
- 2) Remove the panels.
- 3) Close the Water Supply Line Shut-off Valve.
- 4) Recover the refrigerant and store it in an approved container.
- 5) Disconnect the Capillary Tube using brazing equipment.
- 6) Disconnect the Flare-connections of the valve.
- 7) Remove the screws and the valve from the Bracket.
- 8) Install the new valve, and braze the Capillary Tube.
- 9) Install the New Drier
- 10) Check for leaks using nitrogen gas (140 PSIG) and soap bubbles.
- 11) Connect the Flare-connections.
- 12) Open the Water Supply Line Shut-off Valve, and turn on the power supply.
- 13) Check for leaks.
- 14) Evacuate the system, and charge it with refrigerant. See the Nameplate for the required refrigerant charge.
- 15) See "IV. 1. ADJUSTMENT OF WATER REGULATING VALVE." If necessary, adjust the valve.
- 16) Replace the panels in their correct positions.

7. REMOVAL AND REPLACEMENT OF EVAPORATOR ASSEMBLY

- 1) Drain the water from the Evaporator by switching the Flush Switch to “FLUSH” on the Control Box.
- 2) Unplug the icemaker.
- 3) Remove the panels.
- 4) Remove the three Thumbscrews and take off the Spout from the Evaporator.

CUTTER

- 5) Loosen the Cutter by a wrench and remove it.
- 6) Remove the Cylinder Gasket at the top of the Evaporator.

EXTRUDING HEAD

- 7) Remove the three Socket Head Cap Screws and lift off the Extruding Head.
- 8) Replace the Bearing inside the Extruding Head if it exceeds the wear tolerance of 0.02" or is scratched.

Note: Replacing the Bearing requires a bearing press adaptor. If it is not available, replace the whole Extruding Head.

AUGER

- 9) Lift out the Auger. If the area in contact with the Bearing is worn or the Blade is scratched, replace the Auger.

EVAPORATOR

Note: Skip the following steps 10) through 12) when the Evaporator does not need replacement.

- 10) Recover the refrigerant and store it in an approved container.

IMPORTANT

Always install a new Drier every time the sealed refrigeration system is opened. Do not replace the Drier until after all other repair or replacement has been made.

- 11) Remove the Bulb of the Expansion Valve.
- 12) Disconnect the brazing-connections of the Expansion Valve and the Copper Tube-Low Side from the Evaporator, using brazing equipment.
- 13) Remove the two Truss Head Machine Screws and the Bracket securing the Evaporator.
- 14) Disconnect the three Hoses from the Evaporator.
- 15) Remove the four Socket Head Cap Screws securing the Evaporator with the Bearing-Lower.
- 16) Lift off the Evaporator.

BEARING-LOWER AND MECHANICAL SEAL

- 17) The Mechanical Seal consists of two parts. One moves along with the Auger, and the other is fixed on the Bearing-Lower. If the contact surfaces of these two parts are worn or scratched, the Mechanical Seal may cause water leaks and should be replaced.
- 18) Remove the O-ring on the Bearing-Lower.
- 19) Remove the four Bolts and the Bearing-Lower from the Gear Motor. Replace the Bearing inside the Bearing-Lower, if it exceeds the wear tolerance of 0.02" or is scratched.

Note: Replacing the Bearing requires a bearing press adaptor. If it is not available, replace the whole Bearing-Lower.

GEAR MOTOR

- 20) Remove the Coupling-Spline on the Gear Motor Shaft.
- 21) Remove the three Bolts securing the Gear Motor.
- 22) Assemble the removed parts in the reverse order of the above procedure.

WARNING

Be careful not to scratch the surface of the O-ring, or it may cause water leaks. Handle the Mechanical Seal with care not to scratch nor to contaminate its contact surface.

23) When replacing the Evaporator:

- (a) Braze the new Evaporator with nitrogen gas flowing at the pressure of 3-4 PSIG.
- (b) Replace the Drier.
- (c) Check for leaks using nitrogen gas (140 PSIG) and soap bubbles.
- (d) Evacuate the system. Charge it with refrigerant. See the Nameplate for required refrigerant charge and type.

24) Replace the panels in their correct position.

25) Plug in the icemaker.

DCM-500B_F Evaporator Assembly

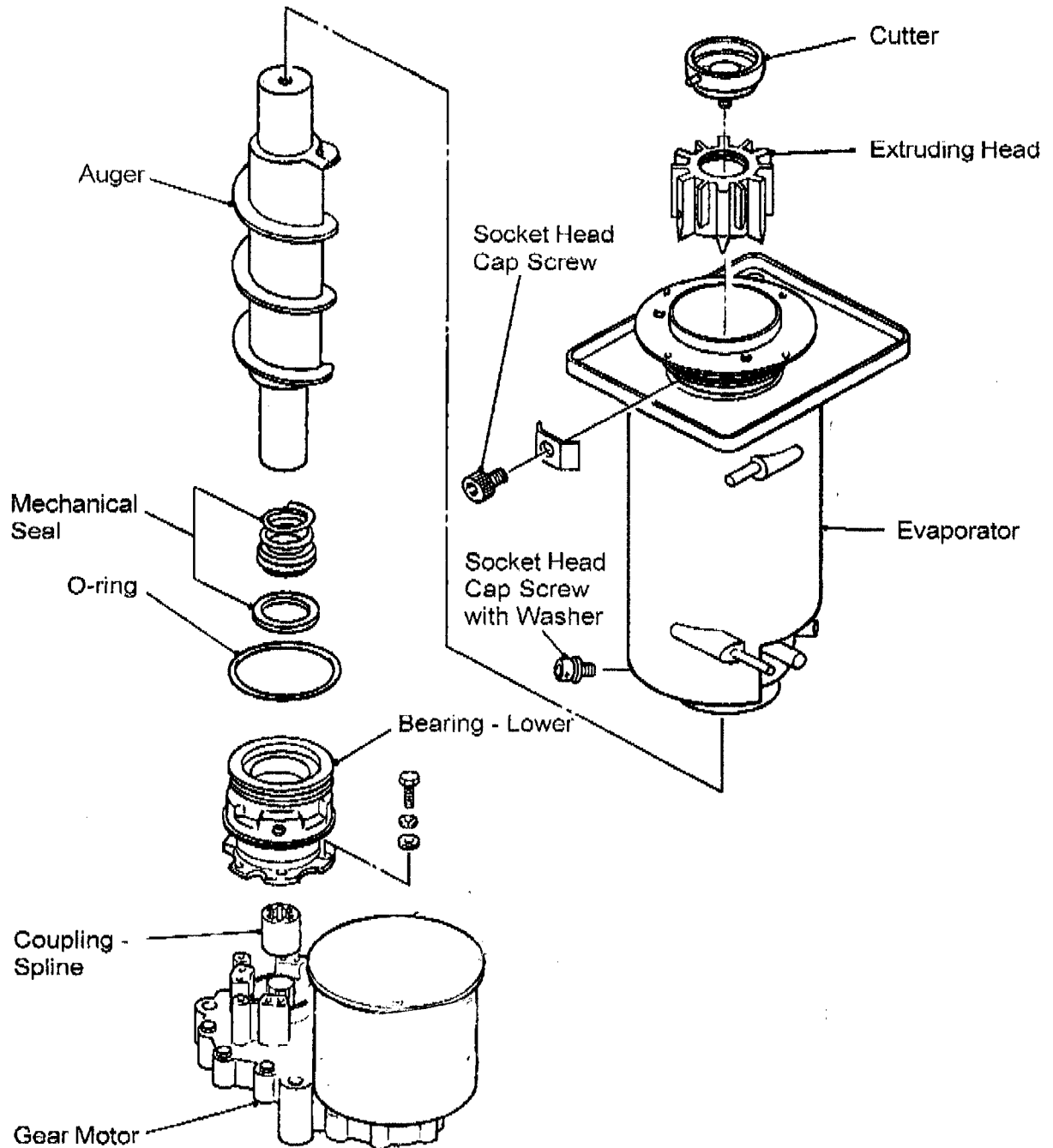

DCM-750B_F Evaporator Assembly

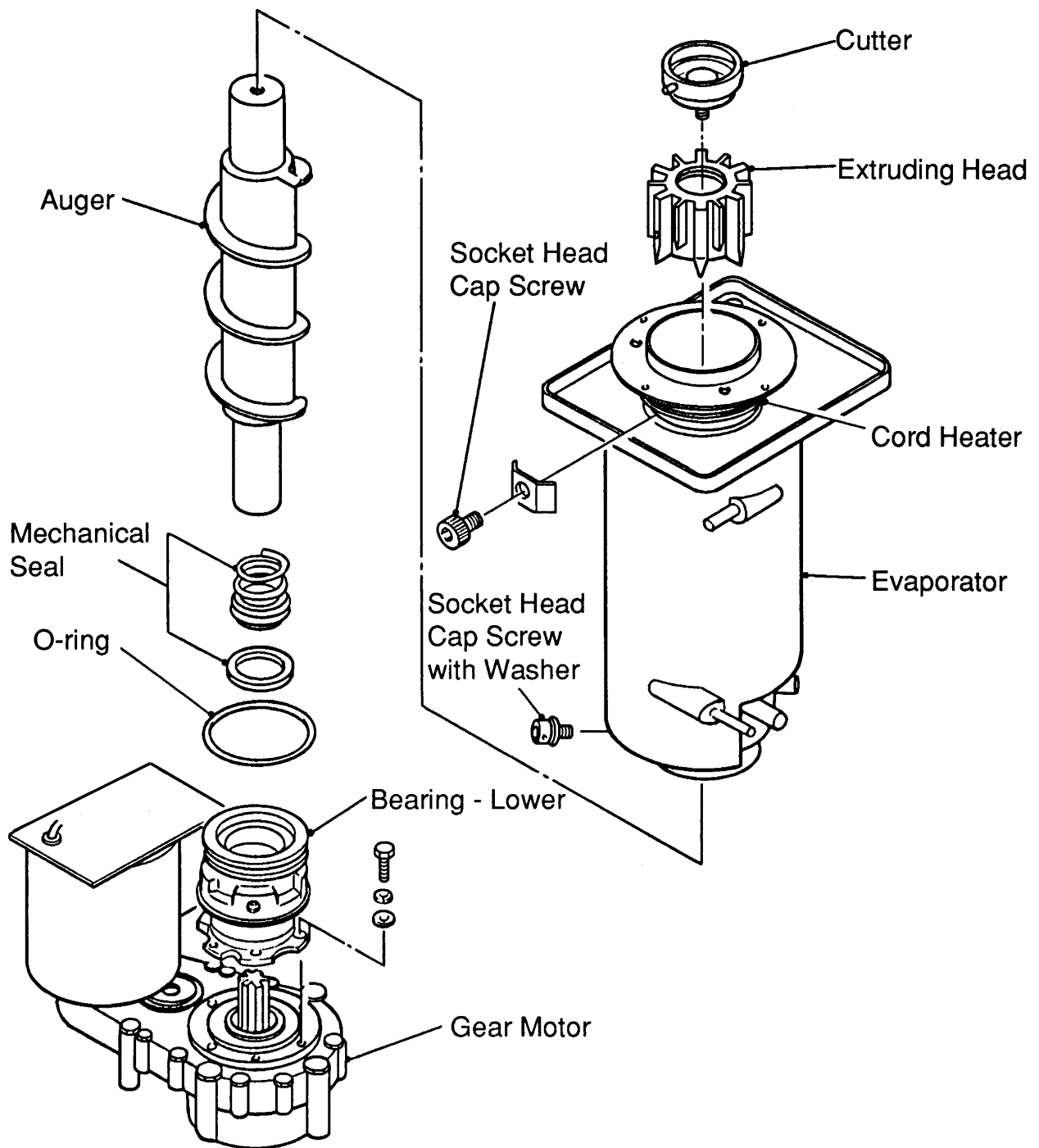

8. REMOVAL AND REPLACEMENT OF FAN MOTOR

- 1) Turn off the power supply and remove the panels.
- 2) Remove the wire connectors from the Fan Motor leads.
- 3) Remove the Fan Motor Bracket and Fan Motor.
- 4) Install the new Fan Motor.
- 6) Replace the Fan Motor Bracket and the wire connectors.
- 7) Replace the panels in their correct position, and turn on the power supply.

9. REMOVAL AND REPLACEMENT OF CONTROL /DISPENSING WATER VALVE

- 1) Turn off the power supply, remove the panels and close the Water Supply Line Shut-off Valve.
- 2) Disconnect the Terminals from the Control/Dispensing Water Valve.
- 3) Loosen the Fitting Nut on the Control/Dispensing Water Valve Inlets, and remove the Control/Dispensing Water Valve. Do not lose the Packings inside the Fitting Nut.
- 4) Remove the Water Supply Hose or Water Pipe from the Control/Dispensing Water Valve.
- 5) Install the new Control/Dispensing Water Valve.
- 6) Assemble the removed parts in the reverse order of which they were removed.
- 7) Open the Water Supply Line Shut-off Valve.
- 8) Check for water leaks.
- 9) Replace the panels in their correct position, and turn on the power supply.

10. REMOVAL AND REPLACEMENT OF FLOAT SWITCH

WARNING

1. Fragile, handle very carefully.
2. If the Float Switch works poorly because of scale or other foreign matter, install a filter or softener in the water supply line.

- 1) Turn off the power supply.
- 2) Close the Water Supply Line Shut-off Valve.
- 3) Remove the panels.
- 4) Open the Drain Valve by rotating the knob, and after draining water, close the Drain Valve.
- 5) Cut the Float Switch leads at the wire connectors.
- 6) Turn and unfasten the flanged top, and remove the Float Switch.
- 7) Install the new Float Switch.
- 8) Assemble the removed parts in the reverse order of which they were removed.
- 9) Open the Water Supply Line Shut-off Valve.
- 10) Turn on the power supply.

11. REMOVAL AND REPLACEMENT OF FLUSH WATER VALVE

- 1) Turn off the power supply.
- 2) Remove the panels.
- 3) Close the Water Supply Line Shut-off Valve.
- 4) Remove the Clamp and disconnect the Hose from the Flush Water Valve that attaches to the Evaporator.

Note: Water may still remain inside the Evaporator. Be sure to drain the water into the Drain Pan.

- 5) Disconnect the Flush Water Valve from the tube connected to the plastic tee leading to the drain hose.
- 6) Disconnect the Terminals from the Flush Water Valve.
- 7) Remove the Flush Water Valve from the Frame or Bracket.
- 8) Connect the new Flush Water Valve back onto the Frame or Bracket.
- 9) Connect the tube from the plastic tee to the new Flush Water Valve.
- 10) Connect the Hose to the Flush Water Valve and secure it with the Clamp.
- 11) Pour water into the Reservoir, and check for water leaks on the Flush Water Valve.
- 12) Open the Water Supply Line Shut-off Valve.
- 13) Turn on the power supply.

12. REMOVAL AND REPLACEMENT OF ELECTRICAL SYSTEM

[a] BIN CONTROL (PROXIMITY SWITCH)

- 1) Turn off the power supply.
- 2) Remove the Front Panel and Top Panel.

Note: The Proximity Switch is located on the outside of the Bin Top Panel.
- 3) Cut the leads at the wire connectors.
- 4) Remove the Switch Cover and the Proximity Switch.
- 5) Install the new Proximity Switch.
- 6) Replace the Switch Cover in its correct position.
- 7) Connect the leads of the Proximity Switch.
- 8) Turn on the power supply.

- 9) To check the Bin Control operation, move the paddle located on the inside of the Bin Top Panel. The Compressor should stop 90 sec. later, and the Gear Motor 150 sec. later.
- 10) Replace the panels in their correct position.

[b] STARTER

- 1) Turn off the power supply.
- 2) Remove the Front Panel.
- 3) Remove the Control Box Cover.
- 4) Disconnect the terminals from the Starter.
- 5) Remove the Starter.
- 6) Install the new Starter.

WARNING

The Starter is position-sensitive. Install it so that the arrow indication of the Starter can point upward. Failing to install it in this way will cause abnormal operation and adversely affect the Compressor operation as well.

- 7) Connect the terminals.
- 8) Assemble the removed parts in the reverse order of which they were removed.
- 9) Turn on the power supply.

13. REMOVAL AND REPLACEMENT OF DISPENSING SYSTEM

[a] AGITATOR

- 1) Turn off the power supply.
- 2) Remove the Front Panel.
- 3) Remove the Bin Front Panel.
- 4) Remove the Thumbscrews and pull off the Gear Motor Bracket.

Note: Hold the Agitator so as not to drop it when pulling off the Gear Motor Bracket.

- 5) Replace the Agitator with the new one.
- 6) Assemble the removed parts in the reverse order of which they were removed.
- 7) Turn on the power supply.

[b] AGITATING GEAR MOTOR

- 1) Turn off the power supply.
- 2) Remove the Front Panel.
- 3) Remove the Bin Front Panel.
- 4) Remove the Thumbscrews and pull off the Gear Motor Bracket.

Note: Hold the Agitator so as not to drop it when pulling off the Gear Motor Bracket.

- 5) Remove the Packing, three flat head screws and Plastic Guide.
- 6) Remove the four flat head screws and the Gear Motor.
- 7) Install the new Gear Motor.
- 8) Assemble the removed parts in the reverse order of which they were removed.
- 9) Turn on the power supply.

[c] DISPENSING AUGER

Same procedure as “[a] AGITATOR”

VII. MAINTENANCE AND CLEANING INSTRUCTIONS

IMPORTANT

Ensure all components, fasteners and thumbscrews are securely in place after any maintenance or cleaning is done to the equipment.

1. PREPARING THE ICE DISPENSER FOR LONG STORAGE

WARNING

When shutting off the ice dispenser for an extended time, drain out all water from the water line and remove the ice from the Storage Bin. The Storage Bin should be cleaned and dried. Drain the ice dispenser to prevent damage to the water supply line at sub-freezing temperatures, using air or carbon dioxide gas. Shut off the ice dispenser until the proper ambient temperature is resumed.

[Air-cooled Models]

- 1) Run the ice dispenser with the Water Supply Line Shut-off Valve closed.
- 2) Open the Water Supply Line Drain Valve and blow out the water inlet line by using air pressure.
- 3) Move the Ice Making Switch at the bottom of the Middle Front Panel to the “FLUSH” position.
- 4) Move the Change Switch at the bottom of the Middle Front Panel to the “CONTINUOUS” position.

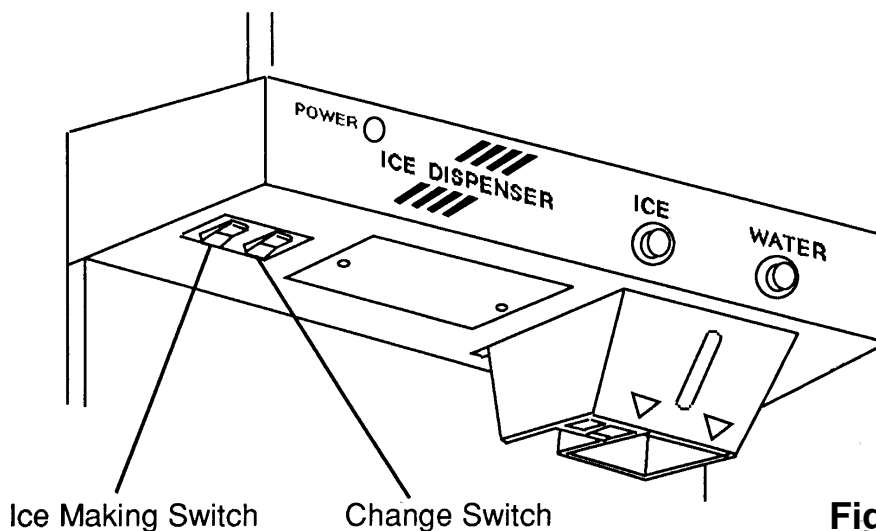

Fig. 4

- 5) Press the Push Button to dispense ice, and remove all ice from the Storage Bin.
- 6) Move the Ice Switch to the “ON” position and unplug the machine.
- 7) Remove the Upper Front Panel.
- 8) Turn off the Power Switch.
- 9) Clean the Storage Bin. See “V.2. [b] STORAGE BIN”.
- 10) Replace the Upper Front Panel in its correct position.

[Water-cooled Models]

- 1) Turn off the Power Switch and wait for 3 minutes.
- 2) Turn on the Power Switch and wait for 20 seconds.
- 3) Close the Water Supply Line Shut-off Valve.
- 4) Open the Water Supply Line Drain Valve and quickly blow the water supply line from the Drain Valve to drain the Condenser.
- 5) Follow the above steps 3) through 10 in [Air-cooled Models].

IMPORTANT

Before operating the dispenser next time, check that the Water Supply Line Drain Valve is closed, and open the Water Supply Line Shut-off Valve.

Note: When shutting off the ice dispenser at sub-freezing temperatures, run the ice dispenser with the Water Supply Line Shut-off Valve closed, and blow out the water inlet line, by using air pressure. See Fig. 5.

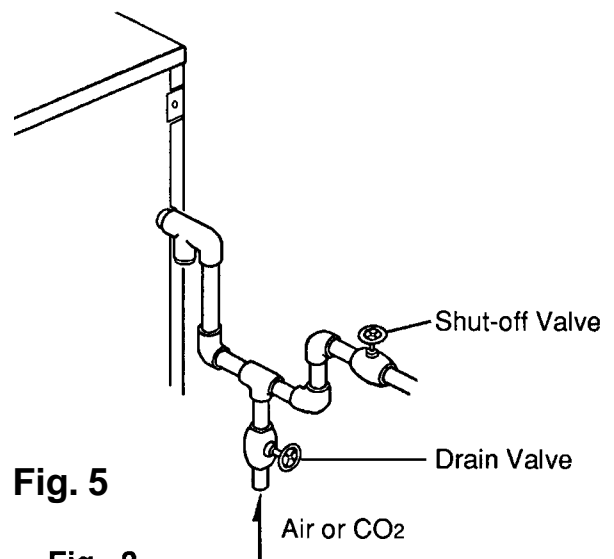

Fig. 5

Fig. 3

2. CLEANING INSTRUCTIONS

IMPORTANT

Ensure all components, fasteners and thumbscrews are securely in place after any maintenance or cleaning is done to the equipment.

[a] WATER SYSTEM

WARNING

1. Clean and sanitize the ice dispenser Water System at least twice a year, by using a recommended cleaner and sanitizer.
2. To prevent injury to individuals, do not use any ammonia type cleaners.
3. Always wear liquid-proof gloves for safe handling of the cleaning and sanitizing solution, to prevent irritation in case of contact with skin.

- 1) Close the Water Supply Line Shut-off Valve.
- 2) Move the Ice Making Switch to “FLUSH” position.
- 3) Move the Dispense Mode Switch, located at left bottom of Middle Front Panel, to the “CONTINUOUS” position.
- 4) Press the Push Button to dispense ice, and remove all ice from the Storage Bin.
- 5) Move the Control Switch, located next to the Dispense Mode Switch, to the “DRAIN” position, and wait for about 15 minutes for the water system to drain.
- 6) Move the Control Switch and the Power Switch to the “OFF” position, and remove the Front Panel and the Top Panel.
- 7) Remove the Water Valve above the Reservoir, and pour in the cleaning solution using a funnel. Be careful not to overfill.

8) Wait for 10 minutes before starting the icemaking process. Then turn on the Power Switch and move the Control Switch to the "ICE" position. Run the ice dispenser until it stops automatically.

Note: This ice dispenser will not run without the Front Panel.
Replace the Top Panel and the Front Panel.

9) Repeat Step 5).

10) Pour water into the Reservoir to rinse the cleaning solution, and drain the water system. See 5).

11) Dilute approximately 0.82 fl. oz. of a 5.25% Sodium Hypochlorite Solution (chlorine bleach) with 1.6 gal. of water.

12) Pour the sanitizing solution into the Reservoir. Be careful not to overfill.

13) Wait for 10 minutes before starting the icemaking process. Turn on the Power Switch and move the Control Switch to the "ICE" position. Run the ice dispenser until it stops automatically.

14) Repeat Step 5).

15) Rinse out the sanitizing solution. See 10).

16) Replace the Water Valve, the Top Panel and the Front Panel.

Note: Be sure to replace the Water Valve Packing.

17) Open the Water Supply Line Shut-off Valve, turn on the Power Switch, and run the ice dispenser for about 30 minutes.

CAUTION

Do not use ice produced from the cleaning and sanitizing solution. Be sure none remains in the Storage Bin.

[b] STORAGE BIN - Following Cleaning Procedures for Water System

- 1) Remove the Front Cover of the Storage Bin.
- 2) Remove the thumbscrews, first from the vertical plane and then from the horizontal plane of the Motor Brackets. Move the Agitating Motor(s) and the Dispensing Motor toward you. Then remove the Agitator(s) and the Dispensing Auger. See Fig. 6.

Note: Models DCM-750BAF and BWF are provided with two Agitators, and models DCM-500BAF and BWF with one Agitator.

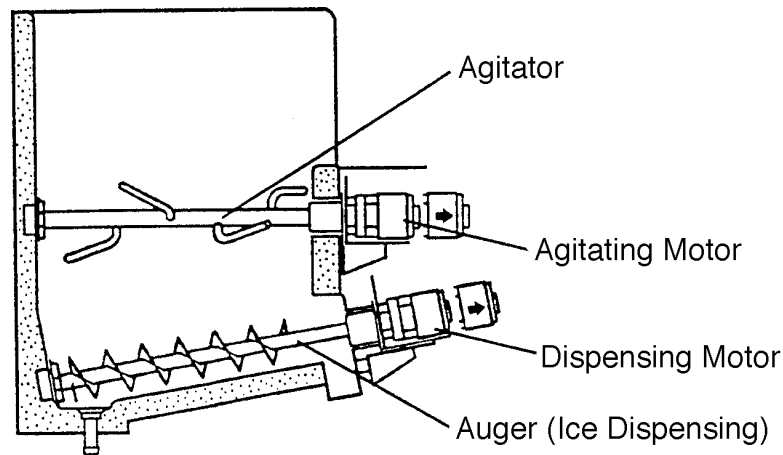

Fig. 6

- 3) Remove the Bin Control Bracket Assembly. See Fig. 7
- 4) Remove the Snap Pin, the Shaft and the Activator.
- 5) Remove the thumbscrews, the Spout-Bin and the Spout Gasket-Bin. See Fig 8. For models DCM-750BAF and BWF, remove the Ice Guide, Drain Pipe Holder and Drain Pipe in the Storage Bin as well.

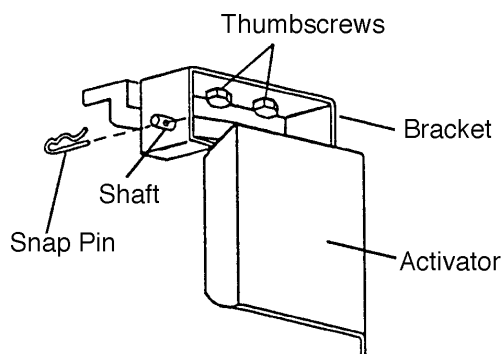

Fig. 7

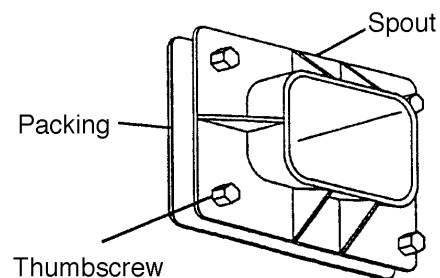

Fig. 8

6. Remove the Spout Cover and, the black Ice Dispensing Spout and the Water Dispensing Nozzle. See Fig. 9.

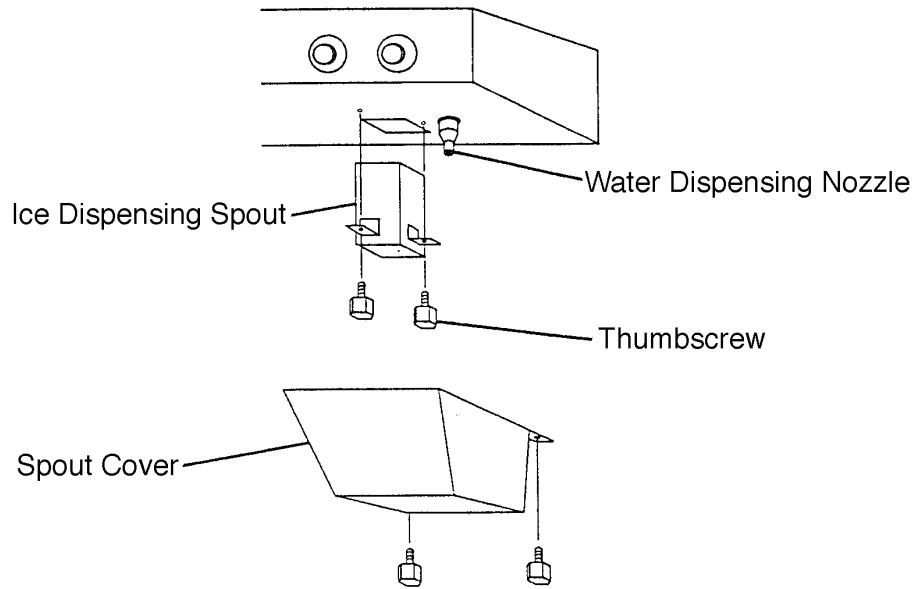

Fig. 9

- 7) Immerse the parts removed in the above steps 2) through 6) in the cleaning and sanitizing solution for about 15 minutes each.
- 8) Rinse these parts thoroughly with clean water.
- 9) Wipe thoroughly the Shutter located above the Ice Dispensing Spout.
- 10) Reassemble the Bin Control Bracket Assembly.
- 11) Replace the Dispensing Auger and Agitator, Bin Control Bracket Assembly, Spout, Packing, black ice Dispensing Spout, Water Dispensing Nozzle and Spout Cover (for DCM-750 series, also the Ice Guide and the Drain Pipe) in their correct position.
- 12) Pour warm water into the Storage Bin to melt the ice produced from the cleaning and sanitizing solution.
- 13) Clean the storage bin liner, and rinse thoroughly.
- 14) Place the Front Cover of the Storage Bin, the Top Panel and the Front Panel back in position.

[c] WATER VALVE

IMPORTANT

If the Filter in the Water Valve becomes clogged with sediment or dirt, the water supply will be stopped and ice cannot be made. Disassemble the Water Valve and clean out the Filter once every two months.

- 1) Unplug the ice dispenser
- 2) Close the water supply tap.
- 3) Remove the panels.
- 4) Remove the Fitting Nut from the Water Valve. Do not lose the Packing.
- 5) Remove the Filter from the Water Valve, remove sediment or dirt and rinse it with water.
- 6) Replace the Filter on the Water Valve.
- 7) Replace the Packing and secure it carefully with the Fitting Nut to prevent leakage.
- 8) Open the water supply tap.
- 9) Plug in the ice dispenser.
- 10) Check for water leaks.
- 11) Replace the panels in their correct positions.

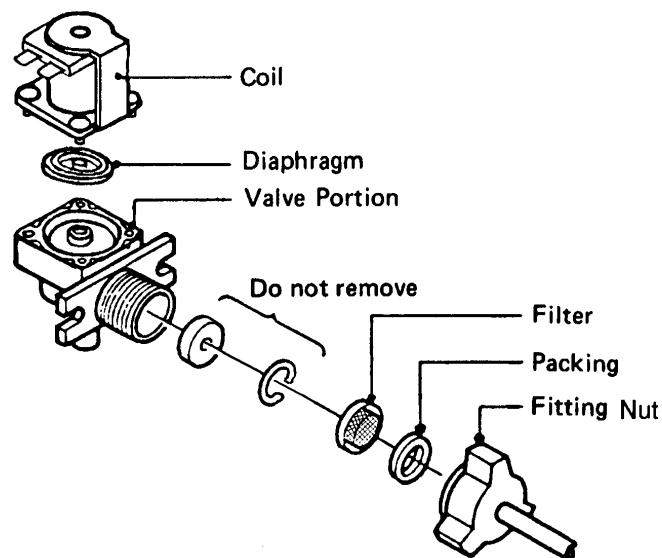

Fig. 10

[d] STRAINER (Optional Extra)

1) Necessary Parts

Strainer Part No. 311166A01 reg. number: 1 pc.

The above part has the following components:

PART NAME	PART NO.	QTY.
Strainer Body	311156-01	1
Filter	415380G01	1
Strainer Cap	418587-01	1
Packing	418588-01	1
Joint	751BX0004	1

2) Installation Method

(1) Attach the Strainer in the water supply line so that the arrow indication can match the actual water flow direction. Install at a location where the Filter by the Strainer can be easily removed, since the Filter has to be cleaned from time to time.

(2) After attaching, check for water leaks at the connection.

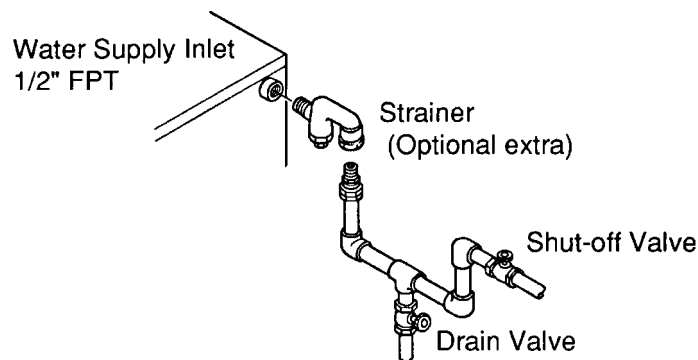

Fig. 11

3) Strainer Cleaning

IMPORTANT

A clogged Strainer will block water supply and cause no ice production. It should be cleaned from time to time.

- 1) Turn off the power supply.
- 2) Close the Water Supply Line Shut-off Valve.
- 3) Open the Drain Valve and drain the water from the water supply line.
- 4) Close the Drain Valve.
- 5) Unscrew the Strainer Cap and remove the Filter inside.
- 6) Use a nylon brush to clean the Filter of all grime, scale, and so on. Then rinse them thoroughly.
- 7) Put the Filter back into the Strainer and secure it carefully with the Packing and the Strainer Cap.
- 8) Open the Water Supply Line Shut-off Valve.
- 9) Check for possible water leakage from the Strainer and Cap connections.
- 10) Turn on the power supply.

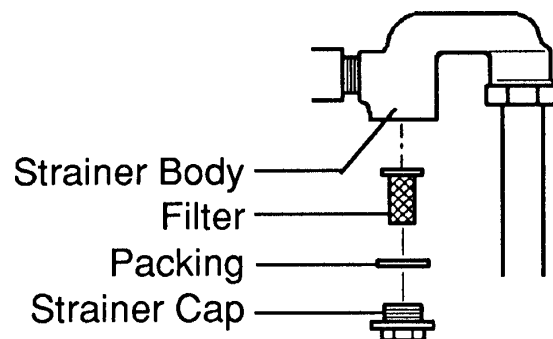

Fig. 12

3. MAINTENANCE

IMPORTANT

1. This ice dispenser must be maintained individually, referring to the instruction manual and labels provided with the ice dispenser.
2. To obtain optimum performance of this ice dispenser, the following consumable parts need periodic inspection, maintenance and replacement:

Extruding Head
Housing
Gear Motor
Auger
Mechanical Seal

These parts should be inspected at least once a year or every 10,000 hours of operation. Their service life, however, depends on water quality and environment. More frequent inspection and maintenance are recommended.

Consult with your local distributor about inspection and maintenance service. To obtain the name and phone number of your local distributor, call Hoshizaki Technical Support at 1-800-233-1940.

1) Stainless Steel Exterior

To prevent corrosion, wipe the exterior occasionally with a clean, soft cloth. Use a damp cloth containing a neutral cleaner to wipe off oil or dirt build up.

2) Storage Bin

- The Storage Bin is for ice use only. Do not store anything else in the bin.
- Clean the bin liner using a neutral cleaner. Rinse thoroughly after cleaning.

3) Air Filter (Air-cooled model only) - See Fig. 13

A plastic mesh air filter removes dirt or dust from the air, and keeps the Condenser from getting clogged. As the filter gets clogged, the ice dispenser's performance will be reduced. Check the filter at least twice a month. When clogged, use warm water and a neutral cleaner to wash the filter.

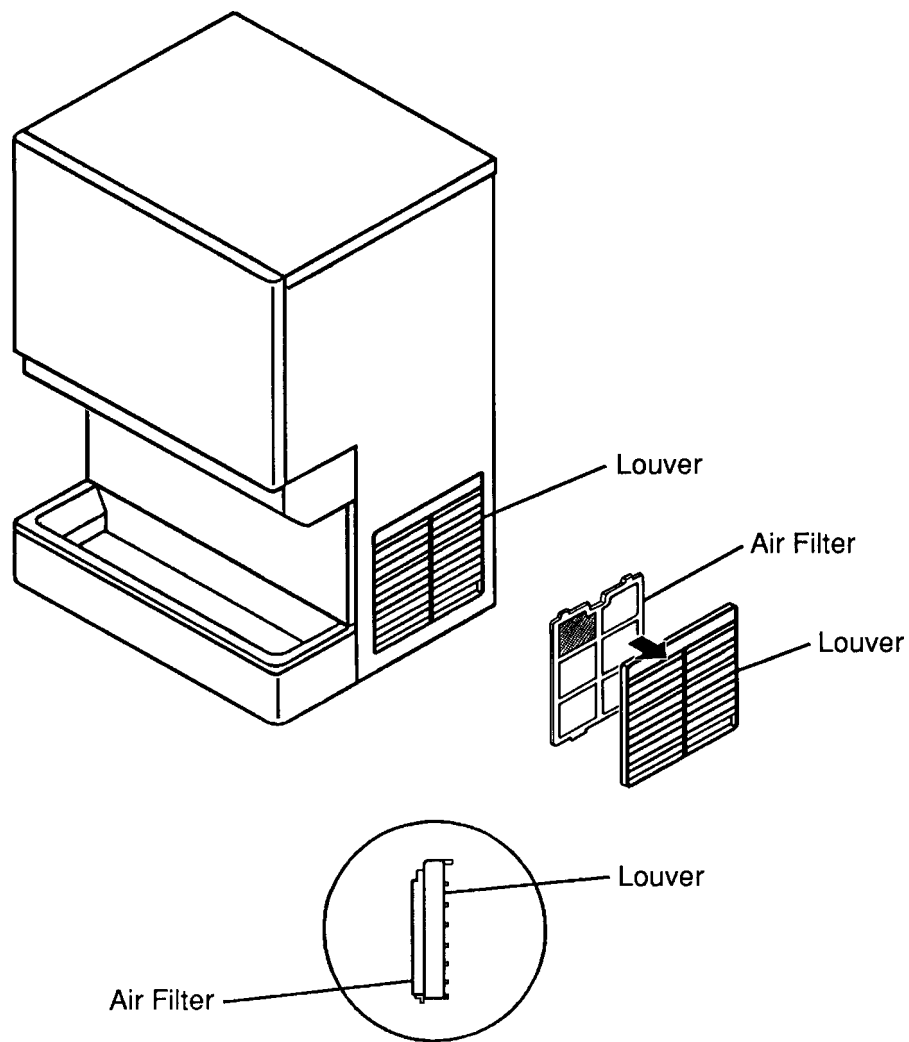

Fig. 13

4) Condenser (Air-cooled model only)

Check the Condenser once a year, and clean if required by using a brush or vacuum cleaner. More frequent cleaning may be required depending on the location of the ice dispenser.

5) Water System

Drain out all water from the Water System at least once a week.