



---

DRAFT BEER DISPENSER

**DBF-25SD-SWA**

# INSTRUCTION MANUAL

L1B009121 (092013)

---

I. INSTALLATION.....	1
1. CONSTRUCTION .....	1
2. UNPACKING AND LOCATION.....	1
3. ELECTRICAL CONNECTIONS.....	1
4. PLUMBING CONNECTIONS.....	2
[a] CO2 GAS CYLINDER .....	2
[b] PRESSURE RANGE.....	2
[c] EXTERNAL CO2 GAS LINE.....	2
[d] EXTERNAL BEER LINE.....	3
5. TRIAL RUN .....	3
[a] HOW TO MAKE COOLING WATER.....	3
[b] COOLING WATER SUPPLY.....	3
[c] CHECKS AFTER INSTALLATION .....	4
II. OPERATION .....	4
1. CHECKS BEFORE OPERATION (DAILY).....	4
[a] CHECKS AND REPLACEMENT OF CO2 GAS CYLINDER.....	4
[b] CHECKS AND REPLACEMENT OF BEER KEG .....	4
2. DISPENSING .....	5
[a] BEER TAP OPERATION .....	5
[b] LEADING BEER TO TAP.....	5
[c] DISPENSING BEER.....	5
[d] END OF OPERATION.....	5
III. MAINTENANCE .....	6
1. BEER CIRCUIT (DAILY).....	6
2. BEER TAP ( DAILY).....	6
3. DRAIN PAN (DAILY).....	6
4. BEER CIRCUIT (EVERY 10 DAYS).....	6
5. BEER TAP (EVERY 10 DAYS) .....	7
6. EXTERIOR (WEEKLY).....	7
7. AIR FILTER (BIWEEKLY) .....	7
IV. INSPECTION .....	8
1. GROUND FAULT CIRCUIT INTERRUPTER (MONTHLY).....	8
2. GAS HOSE AND BEER HOSE (MONTHLY).....	8
3. ATTACHMENT PLUG AND POWER CORD (ANNUALLY / BIANNUALLY) .....	8
4. COOLING WATER (BIANNUALLY).....	8
V. PRODUCT SPECIFICATIONS.....	8

### IMPORTANT

1. This booklet is an integral and essential part of the product and should be kept and preserved by the user. Please read carefully the guidelines and warnings contained herein as they are intended to provide the installer/user with essential information for the proper installation and the continued safe use and maintenance of the product. Please preserve this booklet for any further consultation that may be necessary.
2. This is a draft beer dispenser, and should be destined only to be used for the purpose for which it has been expressly designed. Any other use should be considered improper and therefore dangerous. The manufacturer will not be held liable or responsible for any damage caused by improper, incorrect and unreasonable use.

## I. INSTALLATION

### WARNING

The installation must be carried out by qualified personnel, in accordance with current regulations, according to the manufacturer's instructions.

## 1. CONSTRUCTION

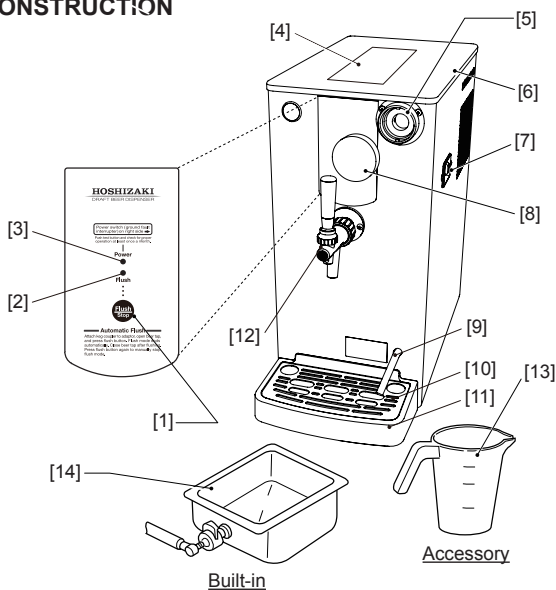

- [1] Flush/stop switch  
Press to start flush mode. This mode stops automatically.  
Press again to stop flush mode manually.
- [2] Lamp (flush)
- [3] Lamp (power)
- [4] Instruction label
- [5] Adapter  
Connect keg coupler when cleaning.
- [6] Top cover
- [7] Ground fault circuit interrupter (GFCI)
- [8] Cap
- [9] Overflow hose
- [10] Drain board
- [11] Drain pan
- [12] Beer tap
- [13] Measuring cup
- [14] Cleaning tank

## 2. UNPACKING AND LOCATION

### CAUTION

1. To prevent injury, wear work gloves and hold the bottom panel to carry the unit. Work in a pair or group.
2. The location should provide a firm and level foundation for the equipment to avoid the risk of water leaks or injury caused by overturn or fall.
3. To prevent possible damage or injury, do not hold the beer tap to carry the unit.
4. This unit is not intended for outdoor use. Exposure to rain may cause electric leakage or shock.

- 1) Inspect the package for damage. Any extensive damage found should be reported to the carrier.
- 2) After removing the packaging, remove the protective plastic film.
- 3) Check the exterior and interior parts for damage.

### IMPORTANT

1. Normal operating ambient temperature should be within 41° F (5°C) to 95°F (35°C).
2. Avoid a site where dripping is not allowed. In high humidity conditions, condensation on the exterior may drip onto the installation surfaces or floor.
3. The unit should not be located next to ovens, grills or other high heat producing equipment.
4. Allow 5 cm clearance at rear and sides for proper air circulation. Otherwise the cooling performance may reduce and electricity costs will increase.
5. Do not remove the labels.

## 3. ELECTRICAL CONNECTIONS

### CAUTION

1. The unit must have a separate power supply. Branching off the power cord, using an extension cord, or sharing a single power supply with other appliances may result in electric shock, heat generation or fire.
2. The connections must be carried out by qualified personnel in accordance with this instruction manual.
3. The maximum allowable voltage variation should not exceed  $\pm 10$  percent of the nameplate rating. Operation of the unit outside of this range may cause smoking, ignition, damage to the unit or reduction of the performance.

### IMPORTANT

1. Check that the power cord is not caught by the unit legs or weighed down with heavy objects.
2. Unplug the unit by holding the attachment plug. To prevent damage, do not jerk the power cord.
3. Do not plug in or unplug the unit with wet hands.

## 4. PLUMBING CONNECTIONS

### IMPORTANT

To sell draft keg beer, prepare and install the following equipment according to the instructions below.

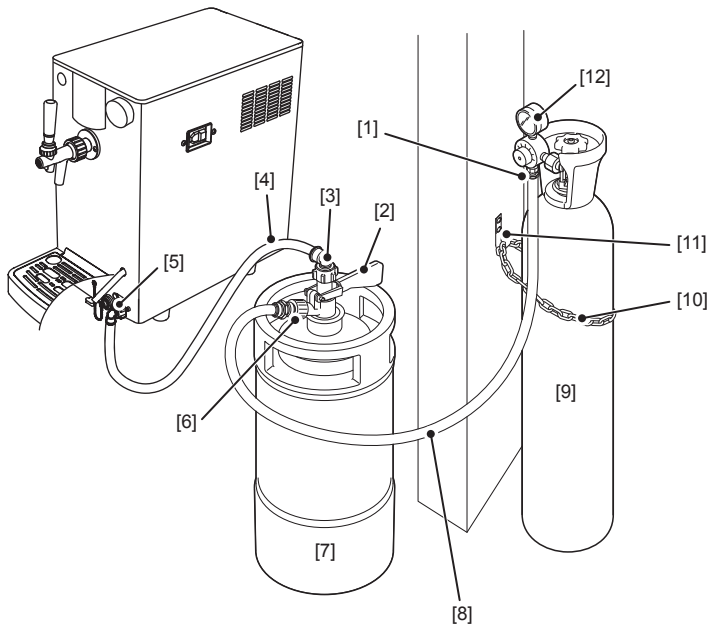

[1] Quick gas hose joint (regulator side)

[2] Keg coupler  
Dispenses beer out of the keg. Consult with the liquor shop or beer company, and prepare a suitable keg coupler for the keg to be used.

[3] Quick beer hose joint (coupler side)

[4] Beer hose

[5] Quick beer hose joint (dispenser side)

[6] Quick gas hose joint (coupler side)

[7] Beer keg

[8] Gas hose

[9] CO2 gas cylinder  
Contains CO2 gas to prevent beer from becoming flat and to push beer out of the keg. Consult with the liquor shop or beer company, and prepare a proper CO2 gas cylinder intended for use with beer.

[10] Cylinder chain (accessory)  
Securely retain the CO2 gas cylinder on the fixed hook.

[11] Hook (accessory)  
Mount on a firm base with the screws provided.

[12] Regulator  
Adjusts CO2 gas pressure in the cylinder for proper beer dispensing. Consult with the liquor shop or beer company, and prepare the required regulator.

### [a] CO2 GAS CYLINDER

- 1) Open the main valve of the new CO2 gas cylinder for a second to splash moisture and dust from the joint. (Keep your face away from the cylinder.)
- 2) Check the regulator gasket. If it is out of position or damaged, gas may leak out.
- 3) Install the regulator on the CO2 gas cylinder. Tighten the nut securely to a torque of 5.9 lbf•ft (8 N•m) so that the level gauge will be upright.

4) Open the main valve, and check the nut for gas leak (sound). If gas is leaking, retighten the nut.

5) After finishing the connections, turn the adjust dial to ensure proper pressure as listed below.

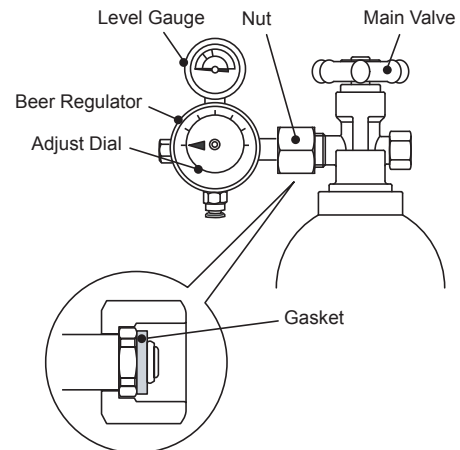

### IMPORTANT

1. Handle the regulator with care to have no impact on it, or the pressure gauge may not read accurately.
2. Stand the CO2 gas cylinder upright, and fix it securely with the accessory chain.
3. Keep the CO2 gas cylinder away from direct sunlight or temperatures above 104°F (40°C).

### [b] PRESSURE RANGE

Adjust the CO2 gas pressure to the following range (reference).

Beer keg temperature	Gas pressure
50°F (10°C)	22 - 29 PSIG (0.15 - 0.20 MPa)
68°F (20°C)	32 - 36 PSIG (0.22 - 0.25 MPa)
86°F (30°C)	46 - 51 PSIG (0.32 - 0.35 MPa)

\* The appropriate keg pressure depends on the type and temperature of beer. Adjust the gas pressure according to the beer company's instructions. Insufficient pressure may result in excessive foaming.

### [c] EXTERNAL CO2 GAS LINE

- 1) Determine the positions of the CO2 gas cylinder and beer keg to make the gas hose length within 4.6 feet (1.4 m).
- 2) Cut the gas hose to have a vertical cutting plane.
- 3) Insert the gas hose into the quick joints on the keg coupler and regulator. Pull the hose hard to check for tight connections.
- 4) Use the adjust dial to check for gas leaks.

### IMPORTANT

1. Cut the gas hose with a specialized tool such as hose cutter. Do not use scissors, or the gas hose may be crushed to cause gas leaks.
2. Do not disconnect and reinsert the gas hose. Cut it about 0.8 inch (20 mm) before reuse.
3. Cut the hose end vertically, insert it securely into the quick joints, and check for gas leaks.

### Quick gas hose joint

1) To insert the gas hose into the quick joint, push it all the way in.

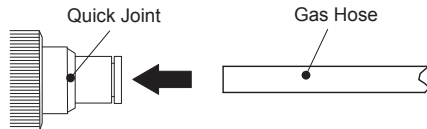

2) To disconnect the gas hose from the quick joint, push it with fingers as shown below and pull it out.

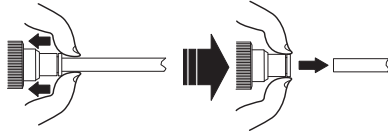

### [d] EXTERNAL BEER LINE

- 1) Attach the O-ring P10A (accessory) on the beer hose adapter (accessory), and install it on the beer inlet.
- 2) Attach the beer hose joint specified by the beer company on the beer hose adapter.
- 3) Determine the positions of the beer hose joint and beer keg to make the beer hose length within 6.9 feet (2.1 m).
- 4) Cut the beer hose to have a vertical cutting plane.
- 5) Insert the beer hose into the quick joints on the keg coupler and quick beer hose joint. Pull the hose hard to check for tight connections.

#### IMPORTANT

1. Cut the beer hose with a specialized tool such as hose cutter. Do not use scissors, or the beer hose may be crushed to cause beer leaks.
2. Do not disconnect and reinsert the beer hose. Cut it about 0.8 inch (20 mm) before reuse.
3. Cut the hose end vertically, insert it securely into the quick joints, and check for beer leaks.

## 5. TRIAL RUN

### [a] HOW TO MAKE COOLING WATER

#### IMPORTANT

Carefully read this before filling the water tank.

#### Electric conductivity (E.C.) of cooling water for water tank (not for cleaning tank)

Do not use tap water.  
Fill the water tank with water having 100-300  $\mu\text{S}/\text{cm}$  of E.C.  
Measure the electric conductivity with conductivity meter.

\* E.C. : Physical property to show the ability of conducting electricity.  
Unit:  $\mu\text{S}/\text{cm}$  (microsiemens)

Below 100  $\mu\text{S}/\text{cm}$ :  
Compressor may not work resulting in poor cooling performance.

Above 300  $\mu\text{S}/\text{cm}$ :  
Excessive ice may build up on evaporator and freeze beer inside beer coil preventing beer from being dispensed properly.

#### How to make cooling water with 100-300 $\mu\text{S}/\text{cm}$ of E.C.

The capacity of the water tank (not cleaning tank) of this unit is approx. 2.5 gal. (10 L).  
Make the cooling water by dissolving 1/16 oz. (2g) of pure baking soda (by ARM & HAMMER) in approx. 2.5 gal. of distilled water.

### Step 1

Measure 1/16 oz. of pure baking soda with nozzle cap (accessory).

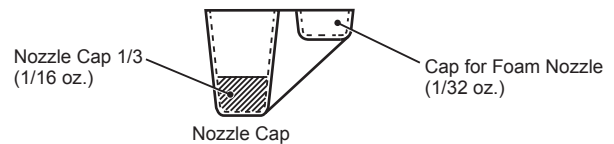

### Step 2

Fill a bucket with approx. 2.5 gal. of distilled water and stir well after adding the 1/16 oz. of baking soda measured in step 1.  
Use a conductivity meter if measuring E.C.  
Rinse the nozzle cap after use.

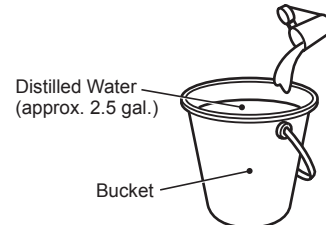

### [b] COOLING WATER SUPPLY

#### IMPORTANT

Fill the water tank slowly not to spill water.

- 1) Unplug the unit.
- 2) Remove the top cover.
- 3) Insert the accessory funnel into the pipe at the top of front cover.
- 4) Use the accessory measuring cup to pour the cooling water into the water tank [approx. 2.5 gal. (10 L)].
- 5) Check that water comes out of the overflow hose. Then stop pouring water.
- 6) Remove the funnel, and refit the top cover.
- 7) Plug in the unit.

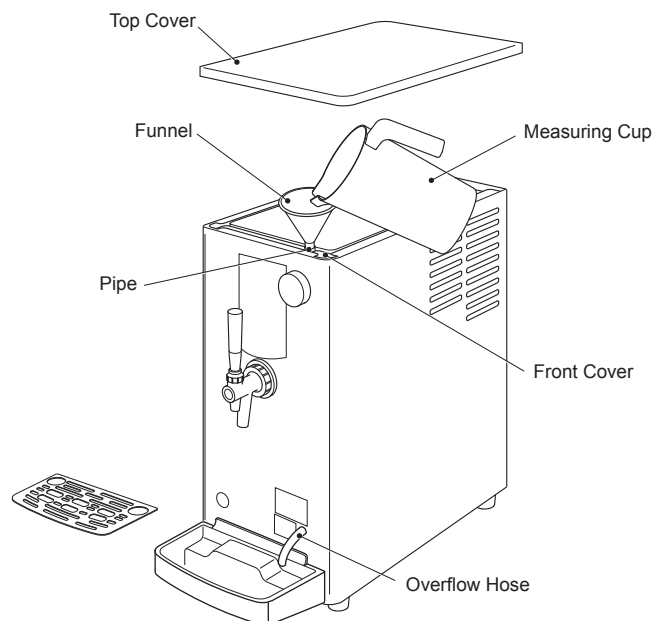

**[c] CHECKS AFTER INSTALLATION**

- \* Normal operating ambient temperature should be within 41°F (5°C) to 95°F (35°C), and beer keg temperature within 50°F (10°C) to 86°F (30°C). Operation outside of these normal temperature ranges may affect performance.
- \* Be sure to use tap water with a turbidity level of not more than 2. Use of well water or other non-tap water or mixture with salt, vinegar, or juice may cause inadequate ice storage, corrosion, or holes.
- \* The beer circuit has been cleaned before shipping. But clean it again before starting up the unit, and check for proper installation of each part.
- \* Check the power cord and hoses before starting up the unit.

**IMPORTANT**

1. Do not install the unit where exposed to humidity or water splashes.
2. Do not remove the top cover or carry the unit with wet hands.
3. Be sure to unplug the unit before removing the top cover for cleaning or inspection.
4. Do not attempt to disassemble, repair, or modify the unit.

**II. OPERATION**

**1. CHECKS BEFORE OPERATION (DAILY)**

**[a] CHECKS AND REPLACEMENT OF CO2 GAS CYLINDER**

- 1) Close the main valve of the CO2 gas cylinder.
- 2) Adjust the regulator to "0".
- 3) Remove the empty regulator from the CO2 gas cylinder.
- 4) Follow the steps 1) to 4) in "I. 4. [a] CO2 GAS CYLINDER".

**IMPORTANT**

Carry a CO2 gas cylinder without shaking.

**[b] CHECKS AND REPLACEMENT OF BEER KEG**

**IMPORTANT**

1. To prevent excessive foaming, do not roll or shake a beer keg. Handle it with care.
2. Excessive foaming is caused by a nearly empty beer keg. Replace it with a new keg as soon as possible.
3. When a beer keg becomes completely empty, CO2 gas will blow out of the beer tap and splash beer.
4. Do not store an open beer keg in a refrigerator. Keep it under 86°F (30°C).

- 1) Close the beer circuit. Unlock and lift the keg coupler handle all the way up.

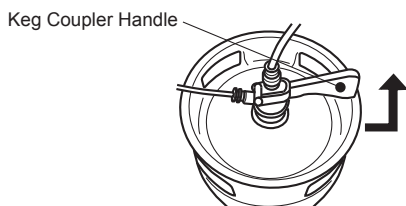

- 2) Turn the regulator adjust dial counterclockwise to "0".

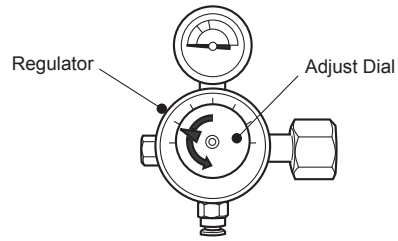

- 3) Turn the keg coupler counterclockwise, and remove it from the keg.

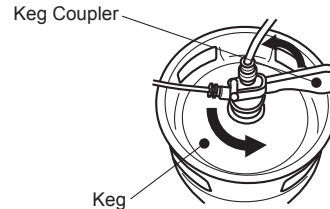

- 4) Attach the keg coupler on the new keg by turning it clockwise.

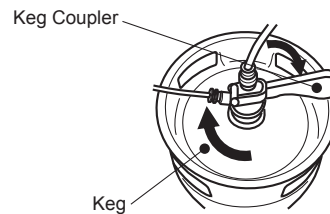

**IMPORTANT**

1. Wash the keg joint with water if necessary.
2. Do not loosen the ferrule on the keg.

- 5) Turn the regulator adjust dial clockwise to the appropriate gas pressure level specified by the beer company.

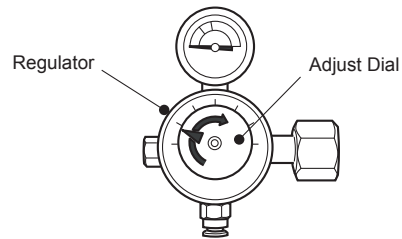

- 6) Open the beer circuit. Push down the keg coupler handle until it locks in place.

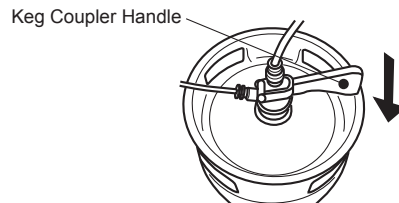

- 7) Before dispensing beer, lead beer to the beer tap according to "2. [b] LEADING BEER TO TAP".

## 2. DISPENSING

### [a] BEER TAP OPERATION

1) To dispense beer, pull the beer tap lever quickly toward you until it stops. Moving the lever slowly or stopping it on the way will cause excessive foaming.

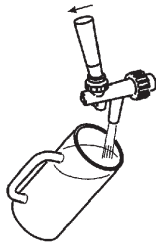

2) To stop beer, move the beer tap lever quickly back to its original position.



3) To dispense foam, push the beer tap lever hard toward the unit from the stop position. To stop foam, move the lever back to its original position.



### [b] LEADING BEER TO TAP

- 1) Check that the regulator adjust dial is set to the appropriate pressure specified by the beer company.
- 2) Check that the beer tap lever is closed. Opening the keg coupler with the beer tap lever open will cause beer to splash out.
- 3) Open the keg coupler.
- 4) Set a mug to receive beer, and push the beer tap lever hard to the back (foam position). Keep pushing it to dispense foam. When the mug is half filled with foam, move the lever back to its original position to stop foam.
- 5) Wait for more than 1 minute after step 4) to settle beer in the circuit.
- 6) Set another mug, and pull the beer tap lever toward you to dispense beer. Keep dispensing beer until foam turns into liquid.
- 7) Check the keg coupler and keg connection and the beer hose joints for beer leaks.

#### IMPORTANT

Frequently dump water and beer from the drain pan. The cooling water in the water tank will increase in volume by taking moisture from the air, and come out through the overflow hose into the drain pan. If left as it is, water will flow out of the drain pan onto the floor.

### [c] DISPENSING BEER

1) Tilt a clean mug at an angle of 45°, and place its inner surface in contact with the liquid nozzle of the beer tap.

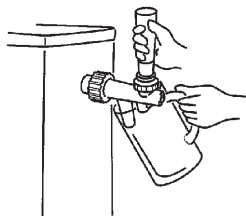

2) Pull the beer tap lever toward you to dispense beer over the inner surface of the mug.

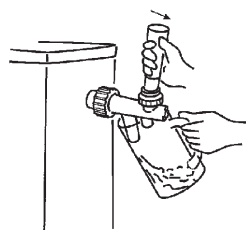

3) After dispensing a specific amount of beer, move the beer tap lever back to its original position to stop beer.

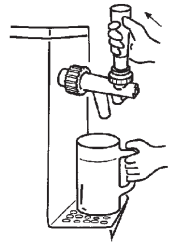

4) To add foam, push the beer tap lever to the back. Foam will keep coming out of the foam nozzle of the beer tap while the lever is pushed. To stop foam, move the lever back to its original position.

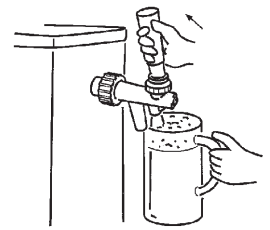

#### IMPORTANT

If the beer circuit is not flushed with beer remaining on the beer tap, the valve shaft jams inside the beer tap, resulting in unavailable, unstable, or continuous dispensing actions. In this case, disassemble and clean the beer tap in accordance with "III. 5. BEER TAP (EVERY 10 DAYS)".

### [d] END OF OPERATION

- 1) Close the keg coupler, and remove it from the keg. Flush the beer circuit according to "III. 1. BEER CIRCUIT (DAILY)" and "III. 4. BEER CIRCUIT (EVERY 10 DAYS)".
- 2) Turn the regulator adjust dial counterclockwise to "0".
- 3) Shut off the CO2 gas cylinder by turning the main valve clockwise.
- 4) Wipe moisture from the nozzle end. Wash the nozzle cap clean, and fit it on the nozzle. The nozzle cap must be removed and stored in a clean place during operation.

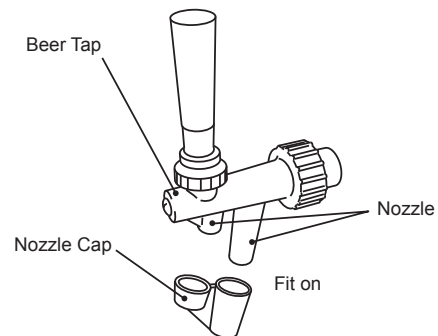

#### IMPORTANT

1. To prevent excessive mixture of CO2 gas in draft keg beer, be sure to close the main valve of the CO2 gas cylinder at the end of operation.
2. The accessory nozzle cap protects the beer tap nozzle against dust or insects while the dispenser is not used. Always cap the nozzle at the end of operation.
3. When the keg coupler on the keg is closed, gas may stay inside the beer circuit. To prevent excessive foaming or improper dispensing actions, lead beer into the beer circuit until gas comes out of the beer tap before starting operation on the following day.

### III. MAINTENANCE

#### IMPORTANT

1. After closing time, be sure to carry out the following maintenance procedures.
2. Follow the maintenance instructions below whenever considered necessary.
3. In cleaning operations, be careful not to lose any parts. The unit will leak water or fail to dispense properly.
4. Always use clean hands and cloths to conduct cleaning operations.
5. As a sanitizer, use a mixture of warm water [86 - 104°F (30 - 40°C)] and 0.34 fl. oz. (10 mL) of 10% invert soap (benzalkonium chloride). Before using the sanitizer, thoroughly read the instructions provided.
6. To prevent damage to the plastic surfaces, do not use thinner, benzine, petroleum, soap powder, polishing powder, alkaline detergent, scrub brush, and especially cleanser for use on fans and cooking ranges. Also, to prevent corrosion, do not use a chlorine bleach (sodium hypochlorite).

#### 1. BEER CIRCUIT (DAILY)

- 1) Close the keg coupler, and discharge beer and CO2 gas from the circuit.
- 2) Remove the cap on the unit. Disconnect the keg coupler from the keg, and reconnect it to the adapter on the unit.

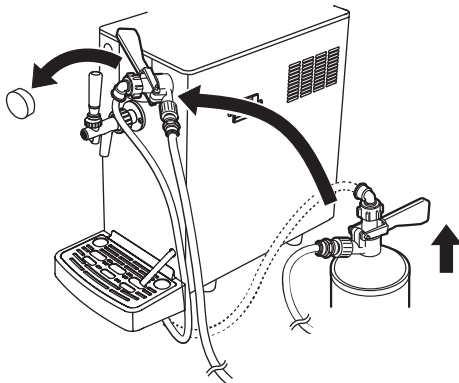

- 3) Fill the measuring cup with 0.48 gal. (1.8 L) of tap water.
- 4) Open the top cover, and pour the above water into the cleaning tank. Close the top cover.
- 5) Place the measuring cup under the beer tap, and pull the beer tap lever toward you. Press the flush/stop switch. The flush lamp is on in the flush mode. The flush mode will be completed automatically in 90 seconds.

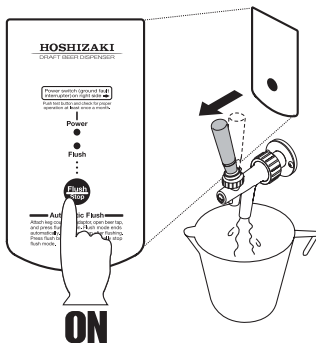

#### 2. BEER TAP (DAILY)

- 1) Loosen the union nut of the beer tap by turning it clockwise, and remove the beer tap.
- 2) Pull the tap lever, and run tap water through the beer tap.
- 3) Refit the beer tap by turning the union nut counterclockwise.

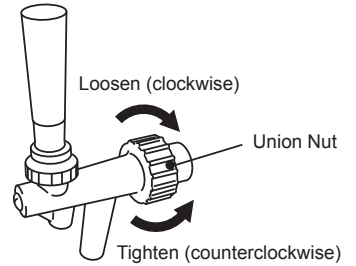

#### 3. DRAIN PAN (DAILY)

Wipe the drain pan surfaces by using a cloth containing warm water [86 - 104°F (30 - 40°C)] with invert soap. After 3 minutes, wipe off any remaining soap with a clean cloth containing cold or warm water. Clean the drain pan whenever necessary.

- 1) Remove the drain board, and lift the drain pan to release its mounting holes from the mounting screws. Be careful not to spill water and beer collected in the drain pan.
- 2) Dump water and beer, and wash the drain board and drain pan with tap water.
- 3) Lift the drain pan to hook the mounting holes on the mounting screws, and set the drain board on the drain pan.
- 4) Check that the overflow hose goes through the hole in the drain board and can drain water into the drain pan.

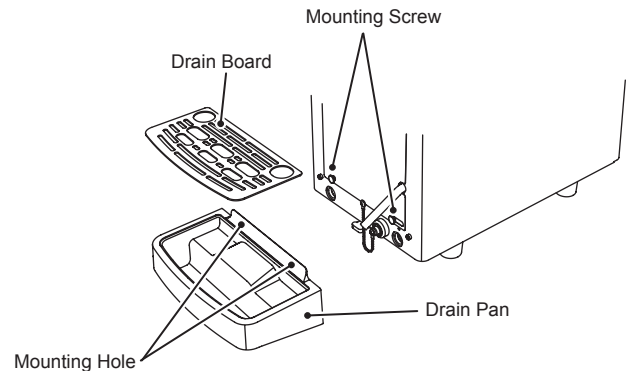

#### 4. BEER CIRCUIT (EVERY 10 DAYS)

- 1) Close the keg coupler, and discharge beer and CO2 gas from the circuit.
- 2) Remove the cap on the unit. Disconnect the keg coupler from the keg, and reconnect it to the adapter on the unit.

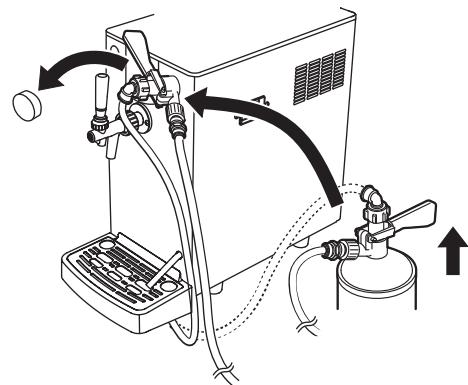

- 3) Fill the measuring cup with 0.48 gal. (1.8 L) of cleaning solution [sodium hypochlorite (80 ppm)].



- 4) Open the top cover, and pour the above cleaning solution into the cleaning tank. Close the top cover.
- 5) Place the measuring cup under the beer tap, and pull the beer tap lever toward you. Press the flush/stop switch. The flush lamp is on in the flush mode. The flush mode will be completed automatically in 90 seconds.

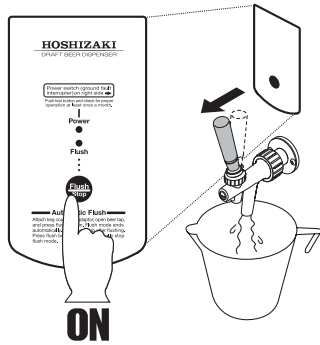

- 6) Fill the measuring cup with 0.48 gal. (1.8 L) of tap water.
- 7) Open the top cover, and pour the above water into the cleaning tank. Close the top cover.
- 8) Place the measuring cup under the beer tap. Press the flush/stop switch. The flush mode will be completed automatically in 90 seconds.
- 9) Repeat steps 6) to 8) at least three times.
- 10) Use litmus paper to check for residual chlorine.

## 5. BEER TAP (EVERY 10 DAYS)

### IMPORTANT

Disassemble and clean the beer tap to prevent remaining beer from dripping.

- 1) Close the beer circuit before flushing.
- 2) Turn the regulator adjust dial counterclockwise to "0".
- 3) Pull the beer tap lever toward you to dispense beer remaining in the circuit. Loosen the union nut of the beer tap by turning it clockwise, and remove the beer tap.
- 4) Loosen the cap nut of the beer tap, and remove the lever.

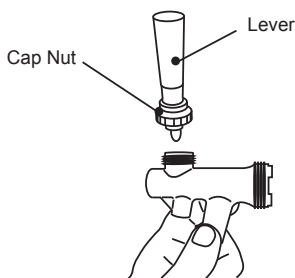

- 5) Remove the valve shaft from the beer tap.

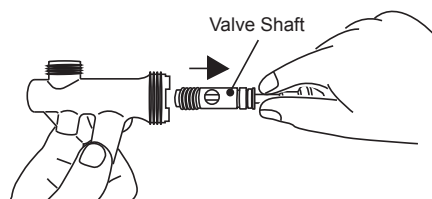

- 6) Clean the beer tap and valve shaft by using a neutral dishwashing detergent and the accessory cleaning brush.
- 7) Use the accessory brush to clean the two small holes in the beer tap.

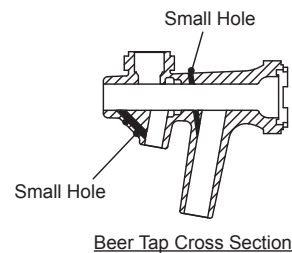
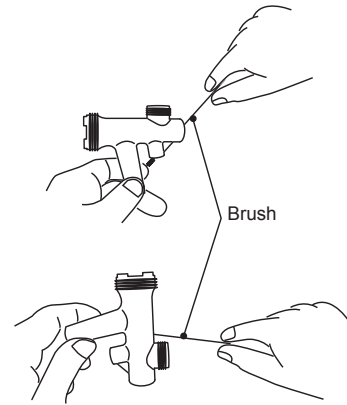

- 8) Rinse the beer tap thoroughly with clean water.
- 9) Assemble the beer tap properly by positioning the hole in the valve shaft (larger hole facing up).

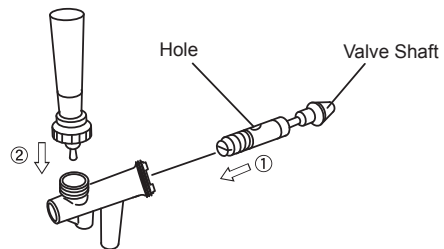

## 6. EXTERIOR (WEEKLY)

The stainless steel exterior also needs cleaning to prevent possible corrosion. Wipe with a soft cloth. Use a soft damp cloth containing a neutral dishwashing detergent to wipe off dirt buildup, and remove any remaining detergent. Clean the exterior whenever necessary.

## 7. AIR FILTER (BIWEEKLY)

- 1) Remove the drain pan.

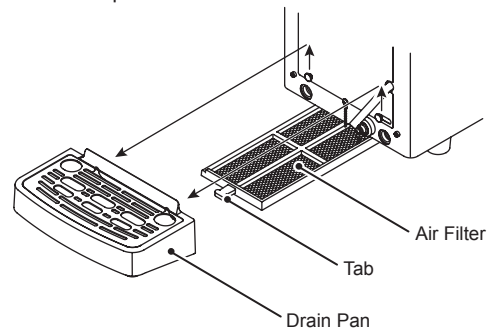

- 2) Pull the air filter slightly toward you. Push it down, and pull it out.

- 3) Wash the air filter with cold water or warm water containing a neutral dishwashing detergent. Be careful not to break the net. After using a detergent, rinse the air filter thoroughly. Dry it in the shade.
- 4) Fit the air filter into the filter guide at the bottom, and slide it to the back.
- 5) Refit the drain pan.

**IMPORTANT**

1. When the air filter is clogged with dirt and dust, the unit cannot operate properly.
2. Do not operate the unit with the air filter removed. The condenser will clog easily.
3. To prevent deformation, do not wash the air filter with hot water above 104°F (40°C).
4. Do not hit or drop the drain pan and air filter while cleaning them.

#### IV. INSPECTION

##### 1. GROUND FAULT CIRCUIT INTERRUPTER (MONTHLY)

**CAUTION**

Check the ground fault circuit interrupter for proper operation once a month. If it is left inoperable, it could increase the risk of electric shock in case of ground fault.

- 1) Press the test button on the ground fault circuit interrupter (GFCI).
- 2) Check that the GFCI switches off.
- 3) If the GFCI does not switch off, unplug the unit, and immediately contact an authorized Hoshizaki service company.

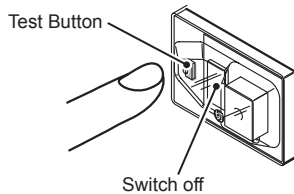

##### 2. GAS HOSE AND BEER HOSE (MONTHLY)

Check the gas and beer hoses for damage, deformation, and water leaks. If any problem is found, contact an authorized Hoshizaki service company.

##### 3. ATTACHMENT PLUG AND POWER CORD (ANNUALLY/ BIANNUALLY)

**CAUTION**

1. Check periodically that the attachment plug blades and their vicinity are free of dust and that the attachment plug is securely plugged into the receptacle. Dusty blades or loose connection may cause electric shock or fire.
2. Do not damage the power cord. It should not be additionally processed, jerked, bundled, weighed down or caught in. It could cause electric shock or fire.
3. The unit must have a separate power supply. Branching off the power cord, using an extension cord, or sharing a single power supply with other appliances may result in electric shock, heat generation or fire.

Check that:

- \* The attachment plug blades and their vicinity and the receptacle are free of dust. Clean them if necessary.

- \* The attachment plug and power cord are not damaged, weighed down or caught in.
- \* The attachment plug is plugged into a separate receptacle.

#### 4. COOLING WATER (BIANNUALLY)

**IMPORTANT**

Replace the cooling water twice a year.

- 1) Unplug the unit.
- 2) Remove the top cover.
- 3) Insert the accessory funnel into the pipe at the top of front cover.
- 4) Use the accessory measuring cup to pour the cooling water into the water tank [approx. 2.5 gal. (10 L)].
- 5) Check that water comes out of the overflow hose. Then stop pouring water.
- 6) Remove the funnel, and refit the top cover.
- 7) Plug in the unit.

#### V. PRODUCT SPECIFICATIONS

Model	DBF-25SD-SWA
Power Supply	1 phase 115V 60Hz Capacity: 0.63kVA (5.5A)
Amperage	Running 2.8A, Starting 20A
Electric Consumption	Rated motor 240W (Power Factor: 74%)
Dispensing Capacity	7.1 gal. (from 86°F to 46.4°F / 4h) [25 L (from 30°C to 8°C / 4h)]
Weight	Net 61.7 lb. (28 kg)
Ambient Temp	41 - 95°F (5 - 35°C)
Voltage Range	Rated voltage ± 10% (104 - 126V)