



PR60B-D4

60" Pizza Prep Table with Drawers



PR60B-D4
03/05/24
Item # 13673

W x D x H

60" x 33.25" x 43.25"*
*to work surface with 6" casters



Dimensions / Capacity

Two-Section PR60B-D4

Interior Storage Capacity (CF) (AHAM)	16.63ft ³
Overall Width x Depth	60" x 33.25"
Height (including 6" casters)	43.25"
Depth with Cutting Board Installed (including 1" bumper)	36.25"
Depth with Drawer Fully Open (including 1" bumper)	57.5"
Pan Capacity (# of 1/3rd size x 4" or 6" deep)	8
Maximum Pan Depth	6"
Crated Weight	450 lbs.
Crated Length x Width x Height	63.75" x 35.75" x 45"

Electrical / Refrigeration

Two-Section PR60B-D4

Voltage	115/60/1
HACR Breaker	15.0 Amps
Electrical Connection (NEMA)	5-15P Ⓢ
Voltage Range	104-126
Ambient Temp. Range	45° to 100°F
Control Setpoint Range	16° to 36°F (rail) / 28° to 40°F (cabin)
Amperage	4
Energy Consumption (kWh/day) @NSF	5.63
Heat Rejection (BTU/Hr.) @NSF	801
Approx. Nominal Compres. BTU/HR (HP)	2431(1/3HP)
Refrigerant / Charge Amount (oz)	R290 (2.4 oz)

Options

- 2" Casters (HS-5037, set of 4)
- 4" Casters (HS-5320, set of 4)
- Overshelves (HS-5639, single)
- Overshelves (HS-5640, double)
- Pan divider kit for rail
- Drawer divider bar (HS-4007, Vertical)
- Stainless steel back panel (factory request)
- Drawer locks (factory request)
- Reversible door (factory request)



Valid in United States, Canada, Puerto Rico and U.S. Territories. Contact factory for warranty in other countries.

Hoshizaki reserves the right to change specifications without notice.

Item #: _____

Project: _____

Qty: _____

AIA#: _____

Features

- ▶ Dual controller system for ideal temperatures in both rail and cabinet
- ▶ Improved airflow from back to front of the rail for more even cooling of all pans in the rail
- ▶ Night/Day Mode- when lid is open set point drops to keep food cool in rail; when lid is closed set point returns to normal so food can stay in rail overnight without freezing

- Engineered to maintain NSF-7 temperatures in 100°F ambient. (Certified to NSF-7 temperatures in 86°F ambient.)
- Environmentally friendly R290 hydrocarbon refrigerant
- Stainless steel exterior front, sides and top with stainless steel interior sides, back and floor.
- Front breathing air flow design with removable louver for easy air filter cleaning
- Solid state digital controller with temperature alarms and LED display (Fahrenheit or Celsius)
- Rail utilizes a unique ducted air distribution system to distribute air evenly and maintain product temperature
- Cabinet and drawers are insulated with 2" of CFC free, foamed in place polyurethane
- Drawer slides are constructed of 14 gauge stainless steel with acetal rollers
- Drawer frames are constructed of 16 gauge stainless steel and securely fastened to cabinet
- Drawers have a 250 lb. dynamic load rating
- Drawers will accommodate (2) 12" x 10" x 6" and (2) 12" x 6" x 6" deep pans (pans by others)
- Provided with a full complement of polycarbonate plastic 1/3rd size pans, 4" deep and adapter bars
- Extruded aluminum flush mount drawer handle
- Magnetic drawer gasket is easily removable for cleaning
- 60" x 19" x 1/2" thick white polyethylene cutting board is standard
- Evaporator coils are epoxy electrocoated (E-Coat) to help fight corrosion
- Standard with 6" casters (two with brakes)
- 10 ft. cord and plug

If GFCI is required, a GFCI breaker MUST be used in lieu of GFCI receptacle



PR60B-D4

60" Pizza Prep Table with Drawers



PR60B-D4
03/05/24
Item # 13673

FRONT VIEW

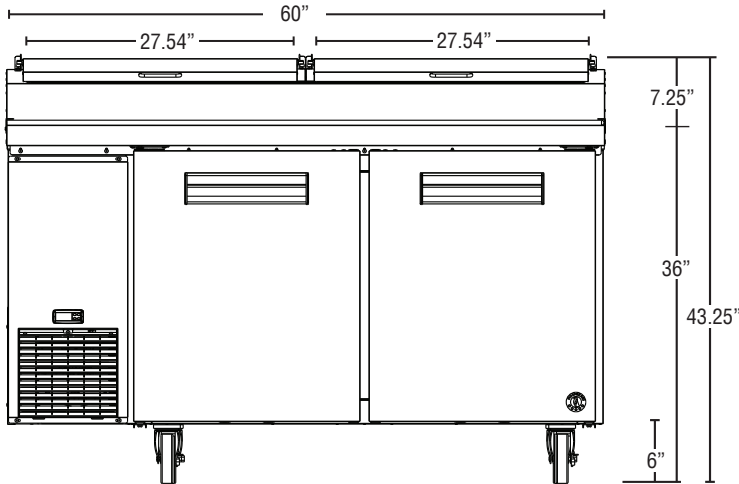

SIDE VIEW

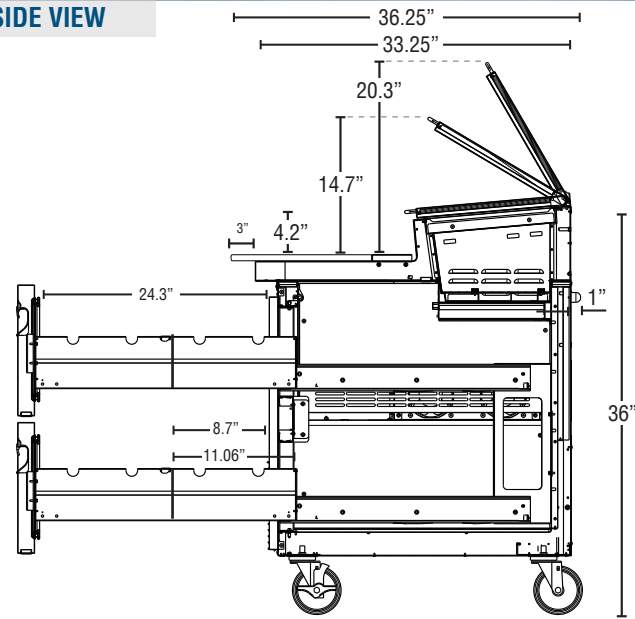

PLAN VIEW

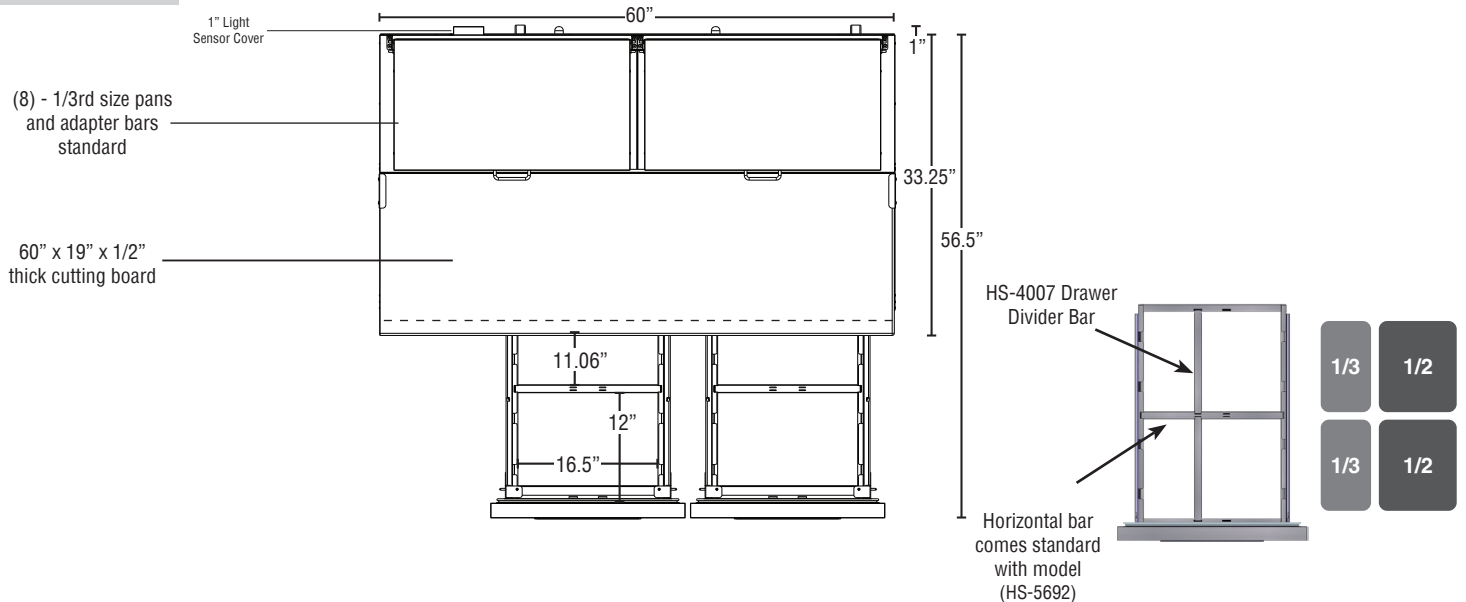

Cabinet Construction

The exterior cabinet top, front, and sides, are constructed of high quality stainless steel. The exterior back and bottom are constructed of coated steel. The cabinet interior back and sides are stainless steel with an ABS ceiling and stainless steel floor. Mounted on anodized aluminum pilasters the shelves are adjustable in 1/2" increments. Cabinet walls and drawers are insulated with 2" of foamed in place polyurethane. 6" polyolefin stem casters (two with brakes) are standard. The raised refrigerated rail is constructed of stainless steel interior and exterior (except back is galvanized steel). The rail is air cooled and utilizes a unique patent pending ducted air distribution system to distribute air evenly and maintain product temperature at safe levels. The rail will accommodate 1/2, 1/3rd, 1/4th, 1/6th, 1/9th, and full size 6" deep pans. Pans are located 1.5" below the front of the rail to assist in access to food product. An insulated, stainless steel, one piece hinged, lid is standard. Pizza preparation table is supplied with a 60" x 19" x 1/2" thick N.S.F. approved white polyethylene cutting board.

Drawer Construction

Drawer fronts are constructed of high grade stainless steel inside and out and are insulated with 2" CFC free foamed in place polyurethane. Each drawer accommodates (2) 12" X 10" X 6" and (2) 12" x 6" x 6" deep pans (pans by others). Drawer module frames are formed of 16 gauge stainless steel all welded construction and securely fastened in the cabinet. The drawer slides are constructed of 14 gauge stainless steel with delrin nylon rollers to prevent metal to metal contact between the drawer slides and help reduce wear. The drawer slides have a dynamic load capacity of 250 pounds. Drawers are provided with a one-piece extruded aluminum flush mount handle. Snap-in magnetic drawer gaskets are durable and easily removed for cleaning.

Refrigeration System

Front breathing refrigeration system allows unit to be built into any enclosure with zero clearance at the side or rear and comes standard with a condenser filter with easy access from the front of the unit. The high efficiency refrigeration system is self-contained with an epoxy electrocoated (E-Coat) evaporator coil for extended life. Condensate removal is accomplished with an energy efficient non-electric evaporation system. A capillary tube controls the flow of environmentally friendly R290 refrigerant through the evaporator. Unit uses a heated, time initiated defrost to eliminate any ice on the evaporator coil. An innovative ducted air distribution system distributes air evenly around food product in the rail. Engineered to maintain NSF-7 temperatures in 100°F ambient. (Certified to NSF-7 temperatures in 86°F ambient.) Pizza preparation tables are supplied with a full complement of N.S.F. approved polycarbonate plastic, 1/3rd size pans, 4" deep and stainless steel adapter bars. 115 volt units are equipped with a ten foot cord and NEMA rated plug (20.0 amps or less).